



**REQUEST FOR BID
FOR
Wolf River Interceptor Rehab**

Bid No. 194677.71.0397

January 11, 2017



City of Memphis, Tennessee

Black & Veatch and Overland Contracting Inc. (OCI), a subsidiary of Black & Veatch, are the Program Manager and Construction Manager respectively, for the SARP10 Program for the City of Memphis.

Overland Contracting Inc.
3485 Poplar Avenue, Suite 230, Memphis, TN, 38111

Table of Contents

00170 - Request for Bid	1
00170.1 Introduction	1
00170.2 Program Overview	1
00170.3 Scope of Work	1
00170.4 Bid Guarantee Requirements	1
00170.5 Request for Bid Definitions	2
00170.6 Minority / Women Business Enterprise (M/WBE) Requirements	2
00170.7 Clarification of Bid.....	2
00170.8 Responsiveness	2
00170.9 Examination of Request for Bid Documents.....	3
00170.10 Interpretations and Addenda	3
00170.11 Modification or Withdrawal of Bid Submittals	3
00170.12 Rejection of Responses.....	4
00170.13 Other Items	4
00170.14 Selection Process	4
00170.15 Selection Schedule	4
00170.16 Mandatory Pre-Bid Meeting.....	5
00270 - Instructions to Bidders	6
00270.1 Bidder's Compliance with Request for Bid	6
00270.2 General Bid Parameters	6
00270.3 Bid Pricing.....	6
00270.4 Supplemental Bid Information	6
00270.5 Schedule Compliance.....	7
00270.6 Compliance with Request for Bid	7
00270.7 Bid Attachments.....	7
00270.8 Declarations.....	7
00270.9 Nondiscrimination	7
00270.10 Equal Business Opportunity Program (EBO)	8
00370 – Commercial Bid Form (13 pages)	9
00571 - Supplementary Terms and Conditions	10
00571.1 Notices and Correspondence	10
00571.2 Not Used.....	11
00571.3 Payment Terms	11
00571.4 Security Instruments	11
00571.5 Liquidated Damages.....	11
00571.6 Taxes	12
00572 - General Terms and Conditions	13
00572.1 Definitions	13
00572.2 Interpretation.....	14
00572.3 Subcontractor's Status.....	14
00572.4 Invoicing and Payment	14
00572.5 Schedule.....	15
00572.6 Waivers of Lien	15
00572.7 Assignment and Subcontracting.....	15
00572.8 Passage of Title, Risk of Loss, and Delivery	15
00572.9 Final Completion.....	15
00572.10 Warranty	16
00572.11 Compliance with Laws.....	16
00572.12 Business Practices	16
00572.13 Claims.....	17
00572.14 Subcontract Revisions and Work Authorizations	17
00572.15 Non-Disclosure	18
00572.16 Suspension of Work.....	18
00572.17 Termination for Cause	18

00572.18	Termination Without Cause	18
00572.19	Purchaser's Remedies.....	18
00572.20	Indemnity	19
00572.21	Insurance Requirements	19
00572.22	Audit.....	20
00572.23	Governing Law and Disputes	20
00572.24	Hazardous Conditions	21
00572.25	Force Majeure.....	21
00574	– Jobsite Operations Terms and Conditions	22
00574.1	Subcontractor Scope of Work.....	22
00574.2	Safety Requirements	22
00574.3	Labor.....	22
00574.4	Work Hours	22
00574.5	Protection and Restoration of Property	23
00575	- Safety, Health and Accident Prevention.....	24
00575.1	Project Safety and Health Program	24
00575.2	Safety, Health, and Accident Prevention Program	24
00575.3	Hazardous Waste Project Health and Safety Plan.....	24
00575.4	Protective Clothing, Equipment and Instrumentation	24
00575.5	Safety and Health Representative.....	25
00575.6	Safety and Health Goal.....	25
00575.7	Drug Prevention Program.....	25
00575.8	Fall Protection.....	25
00575.9	Sub-subcontractor Safety Prequalification	26
00575.10	Confined Spaces	26
00672	- General Conditions Attachments.....	27
00672.1	Partial Waiver and Release of Lien Rights	27
00672.2	Final Waiver and Release of Lien Rights	29
00672.3	Certificate of Nondiscrimination (1 page)	31
00672.4	Equal Business Opportunity Program	33
00672.5	Report of Disadvantaged Business Enterprise Participation Form (1 page).....	35
00672.6	State Revolving Fund (SRF) Front-Ends (48 pages)	36
00672.7	Bid Bond	37
00672.8	Schedule Impact Due to Weather.....	38
00672.9	Code of Conduct.....	39
00770	– Loss Control Manual	40
	Technical Specifications (61 pages)	41

00170 - Request for Bid

00170.1 Introduction

Sealed bids will be received at the Office of the City of Memphis Environmental Administration, Room 620, City Hall, 125 N. Main, Memphis, TN 38103, until **3:00 p.m. local time, February 9, 2017** for furnishing the City of Memphis with the following:

FOR THE DIVISION OF: PUBLIC WORKS FOR THE CONSTRUCTION OF:
SARP10 Program **Wolf River Interceptor Rehab**

The Sealed Bid envelope must be labeled with the project name, bidder's name, license bidder number, license expiration date, license classification. The Sealed Bid envelope must contain one (1) hardcopy of the bid and one (1) electronic CD copy of the bid.

Sealed Bids that are sent through the mail or other such delivery service shall be sent in such a manner so as to allow the opening of the "Mailing Container" and still have intact the sealed Bid. On the Mailing Container the sender shall state the words that a **"SEALED RESPONSE IS ENCLOSED"** and the Bid number.

Subcontractors intending to bid on this project must follow the instructions for Registration as stated in the Advertisement Legal Notice Request for Bid No. **194677.71.0397** (dated January 11, 2017). Registration information must be submitted by **January 31, 2017**.

00170.2 Program Overview

The Program consists of the management of the capital program needed to bring the City's wastewater and sewer system into compliance with federal and state regulations per The City of Memphis Wastewater Collection and Transmission System (WCTS) Condition Assessment and Rehabilitation Program Consent Decree signed on September 21, 2012, including the procurement of studies, design and construction services associated with the City of Memphis SARP10 Program.

00170.3 Scope of Work

The general Scope of Work for this RFB consists of installing cured-in-place pipe (CIPP) or coating system on approximately 1,350 feet of 96-inch diameter sewer main located near the intersection of I-40 and Hwy 51. Other related work will include bypass pumping, restoring the disturbed area, and installing special suction structure for bypass.

00170.4 Bid Guarantee Requirements

Guarantee Requirements:

- (a) Bidder will not withdraw bid for one hundred eighty (180) calendar days after opening of bids without Purchaser's written consent.
- (b) If bid is accepted, bidder will enter into formal Subcontract with Purchaser, within five (5) calendar days after receipt of Subcontract documents for execution.
- (c) If bid is accepted, bidder will execute required 100% Performance/Payment Bond in accordance with Article 00571.4 and will obtain required insurance coverage in accordance with Article 00572.21 within ten (10) calendar days after receipt of Subcontract.
- (d) All bids will require a bidder's bond or certified or cashier check made payable to the Purchaser on a solvent bank in the amount of 5% of the bid. Said instrument to remain in effect and will be returned only after the Subcontract has been fully executed and secured. Additionally, the successful bidder shall execute a performance bond in an amount equal to 100% of the Subcontract sum as security for the faithful performance of



the Subcontract and for the payment of labor and material furnished and incorporated into the Work. The only acceptable form of instrument for this bid bond is bound herein, Article 00672.7.

Bidder shall be liable to the Purchaser for full amount of proposal guarantee as representing damage to the Purchaser on account of default of bidder if:

- (a) Bid is withdrawn within one hundred eighty (180) calendar days after receipt of bids without approval by Purchaser.
- (b) Bidder fails to enter into contract with Purchaser and execute required Performance Bond and provide required insurance coverage within ten (10) calendar days subsequent to notice of award of the Subcontract.

Firms desiring to submit a Bid should carefully review these instructions. Compliance with all requirements will be solely the responsibility of the Respondent.

00170.5 Request for Bid Definitions

Terms used in this Request for Bid documents are defined and have the meanings assigned to them as follows. The term "OCI", "Purchaser" or "Program Manager" means Overland Contracting Inc. The term "Respondent", "Firm", "Company", "Subcontractor" or "Bidder" means one who submits a Response for the purpose stated in this Solicitation Request for Bid documents. The terms "BID", "Response" or "Respondent's Response" mean all submittal documents provided by the Respondent as required by this Request for Bid. The terms "Request for Bid" or "Bid Documents" mean the documents included in this Request for Bid.

Every effort has been made to use industry-accepted terminology in this Request for Bid. Any statement in this document, which uses words such as "must", "shall", "should", "provide for" or "have/provide the capability of/for", means that compliance with the intent of the statement is mandatory and that failure by the Respondent to satisfy that intent may be cause for the Response to be rejected.

00170.6 Minority / Women Business Enterprise (M/WBE) Requirements

This section shall set forth the respondent's M/WBE Participation Plan that must be submitted and include: (1) the level and dollar amount of participation your firm anticipates to achieve in the performance of the Subcontract resulting from this RFB; (2) the type of Work to be performed by the M/WBE firms participating; and (3) the names of the M/WBE firms the Respondent plans to utilize in the performance of the Subcontract resulting from this RFB.

SRF Fair Share Goals:

MBE goal - Construction 2.6%

WBE goal - Construction 2.6%

(Vendors from the TDOT TNUCP DBE list, other State or Federal DBE lists, or the City of Memphis EBO list)

SARP10 DBE Participation goal: 15%

(Vendors from the City of Memphis EBO list only)

00170.7 Clarification of Bid

Purchaser reserves the right to obtain clarification of any point in a Response or to obtain additional information as necessary to properly evaluate a particular Response. Failure to respond to such request for additional information or clarification in a timely manner may result in rejection of the Response.

00170.8 Responsiveness

Respondents should respond to all requirements of the Bid to the maximum extent possible and are required to clearly identify any limitations or exceptions to the requirements.

00170.9 Examination of Request for Bid Documents

Before submitting a Response, each Respondent must:

Study and carefully correlate the Respondent's observations and responses with the Bid Documents.

Notify Purchaser, of all conflicts, errors and discrepancies, if any, in the Bid Document submitted.

Review the Loss Control Manual and State Revolving Fund (SRF) Documents.

Respondents by and through the submission of their Response, agree that they shall be held responsible for having therefore familiarized themselves with the nature and extent of the requirements in the Bid Documents.

00170.10 Interpretations and Addenda

If any prospective Firm is in doubt as to the true meaning of any part of the Requirements For Preparing and Submitting Bid Submittal for the requested services, they may submit a written request (verbal requests will not be accepted) for an interpretation before the Last Date for Bidder Questions as stated in 00170.15. The person submitting the request will be responsible for its prompt delivery. Any interpretation of the proposed documents will be made only by addendum transmitted to each party receiving a set of such documents. Purchaser will not be responsible for any other explanations or interpretations of the proposed documents. Any requests not submitted within this time period will be deemed waived.

SUBMIT ALL QUESTIONS BY E-MAIL TO:

Attn: Josh Grabowski

josh.grabowski@rccsc.net

Cc: Ginny Dorsey

DorseyV@bv.com

Cc: Brad Davis

DavisBJ@bv.com

(Reference: *SARP10 Program Wolf River Interceptor Rehab, Bid No. 194677.71.0397*)

All requests or questions should be clearly marked and must be received by Last Date for Bidder Questions as stated in 00170.15.

A response will be returned via Addendum to all Firms along with the original question(s).

There shall be no communication between the Firm, their employees or subcontractors concerning this Bid to anyone within Black & Veatch, OCI, Allen & Hoshall, Allworld Project Management, Gresham Smith and Partners, Integrated Circles Technologies, Tamco, Carter-Malone Group, Rohadfox Construction Control Services Corporation, or City of Memphis employee or any such person's spouse, child, parent, brother, sister, dependent or person assuming a relationship being the substantially equivalent of the above except through Brad Davis. **Failure to comply with this requirement will be grounds for disqualification.**

00170.11 Modification or Withdrawal of Bid Submittals

Responses may be modified or withdrawn by an appropriate document duly executed (in the same manner that a Response must be executed) and delivered to the place where Responses are to be submitted at any time prior to the submission deadline. A request for withdrawal or a modification must be in writing and signed by an authorized person. Evidence of such authority must accompany the request for withdrawal or modification. Withdrawal of a Response will not prejudice the rights of a Responder to submit a new Response prior to the Response deadline. After expiration of the period for receiving Responses, only Purchaser may request clarifications or additional information.

00170.12 Rejection of Responses

To the extent permitted by applicable local, state and federal laws and regulations, Purchaser reserves the right to reject any and all Responses, to waive any and all informalities not involving price, time, or changes in the Work with the successful Respondent, and the right to disregard all non-conforming, non-responsive, unbalanced or conditional Responses. Also, Purchaser reserves the right to reject a Response, in its sole discretion, if the City of Memphis believes that it would not be in its best interest to make an award to that Respondent.

Purchaser reserves the right to reject any Response if the evidence submitted by the Responder or if the investigation of such Respondent fails to satisfy Purchaser that such Respondent is properly qualified to carry out the obligations and to complete the Work contemplated therein. All Responses will be rejected if there is reason to believe that collusion exists among Respondents. Responses will be considered irregular and may be rejected if they show serious omissions, alterations in form, additions not called for, conditions or unauthorized alterations, or irregularities of any kind.

00170.13 Other Items

This Bid does not commit Purchaser to enter into a Subcontract, nor does it obligate Purchaser to pay for any costs incurred in the preparation and submission of Responses or in anticipation of a Subcontract. Costs of preparing the Bid in response to this request are solely the responsibility of the Respondent.

By responding to this solicitation, the respondent attests that no employee of Black & Veatch, OCI, Allen & Hoshall, Allworld Project Management, Gresham Smith and Partners, Integrated Circles Technologies, Carter-Malone Group, Rohadfox Construction Control Services Corporation, or City of Memphis employee or any such person's spouse, child, parent, brother, sister, dependent or person assuming a relationship being the substantially equivalent of the above, has an existing or pending, direct or indirect, financial interest in the respondent's business.

No Respondents to this solicitation shall discriminate against any employee or applicant for employment because of race, religion, color, sex, age, or national origin.

00170.14 Selection Process

Purchaser intends to select one Firm based on price and successful completion and approval of the OCI Registration process. There is a local contractor preference of 5%. For evaluation purposes the 5% will be applied to the Total Estimated Unit Price Value.

00170.15 Selection Schedule

The following schedule will be adhered to during the selection process. It is subject to change at the sole discretion of OCI.

<u>Event</u>	<u>Completed By</u>
Advertising Date	January 11, 2017
Pre-Bid Meeting	January 24, 2017 9:30AM local time
Registration Information submitted per 194677.71.0397 Advertisement	January 31, 2017
Last Date for Bidder Questions	January 31, 2017
Issue Addendum for answers to questions	February 2, 2017
Receive all Bids	February 9, 2017 by 3:00PM local time
Public Opening	February 9, 2017 immediately following receipt of Bids
Public Notice of Intent to Award	February 14, 2017



<u>Event</u>	<u>Completed By</u>
Preconstruction Meeting with Subcontractor	February 28, 2017
Tentative Notice to Proceed	February 28, 2017

00170.16 Mandatory Pre-Bid Meeting

A mandatory pre-bid meeting will be held at **9:30 AM (local time)** at the **Benjamin Hooks Central Library 3030 Poplar Avenue Memphis, TN 38111** on **January 24, 2017**. Bidders are required to attend at their own cost.

00270 - Instructions to Bidders

00270.1 Bidder's Compliance with Request for Bid

Provide the information requested and any supporting information necessary to permit a complete analysis of your bid. You acknowledge that preparation and submission of a bid will be at your sole cost and that you will treat this RFB and any resulting discussions as confidential. If you do not agree to treat this RFB and associated discussions as confidential, return the complete RFB to Purchaser and delete or destroy any copies you made.

00270.2 General Bid Parameters

Provide the information requested in Section 00270 and Section 00370 in the appropriate fields of Section 00370. Complete each line of Section 00370 in its entirety and submit it with your bid in accordance with Section 00170. Do not alter Section 00370 forms in any way or deviate from the terminology used or the unit of measure indicated when completing Section 00370. Submit Section 00370 forms in their original core application software, with no embedded programming and no permissive encoding restricting access to the data provided.

00270.2.1 Bidder's Contact Information

Include contact information for your representative in Article 00370.2.1. Your representative must have the appropriate expertise and authority to negotiate on behalf of your company.

00270.2.2 Addenda to Request for Bid

In Article 00370.2.2, list all addenda received from Purchaser and indicate "Yes" to show your receipt of and incorporation of the listed addenda into the proposal. Address any exceptions or clarifications to addenda in accordance with Article 00270.6.

00270.3 Bid Pricing

You must include numerical values in the applicable fields of Table 00370.3.1. Non-numerical values, such as "included" or "not applicable," are not acceptable. Purchaser will evaluate fields left blank or filled with a zero as scope included in your bid at no cost.

00270.3.1 Unit Pricing

Provide the unit prices to perform the Work in accordance with this RFB in Table 00370.3.1. A unit price is the total amount to be billed to Purchaser for a specific unit of work. Unit pricing includes all costs, overhead, profit and mark-up associated with delivering the complete unit.

00270.4 Supplemental Bid Information

00270.4.1 Company Status

In Article 00370.4.1, indicate the type of your organization's legal entity and the state and country in which it is organized.

00270.4.2 Contractor License

If you are not licensed to perform the Work, indicate "No" in Article 00370.4.2. If you indicate "No," declare an exception in accordance with Article 00270.6.

00270.4.3 Not Used

00270.4.4 Bid Validity Period

Indicate "Yes" in Article 00370.4.4 if your proposal is valid for one hundred eighty calendar days after the Proposal Due Date (the "Proposal Validity Period"). If you indicate "No" in Article 00370.4.4, provide the number of calendar days that your proposal is valid in Article 00370.4.4 and declare an exception in accordance with Article 00270.6. Purchaser may reject your proposal without prior notice if your proposal is not valid for the full Bid Validity Period.

00270.4.5 Firm Non-Escalatable Pricing

Indicate "Yes" in Article 00370.4.5 if the proposal pricing is firm and not subject to escalation. If you indicate "No," declare an exception in accordance with Article 00270.6 and include the terms of escalation in your exception.

00270.4.6 Taxes

Tax requirements are identified in Article 00571.6. Indicate "Included" in Article 00370.4.6 if your proposal includes the tax requirements. If you indicate "Excluded" in Article 00370.4.6, declare an exception in accordance with Article 00270.6.

00270.4.7 Work at Jobsite

Identify the type of craft labor. If you plan to subcontract any of the Work, indicate "Yes" in the appropriate section of Article 00370.4.7 and complete Table 00370.4.7.

00270.5 Schedule Compliance

Indicate "Yes" in Article 00370.5 if you can meet the schedule dates included in Table 00370.5. If you indicate "No," submit an alternative summary level schedule with your proposal.

00270.6 Compliance with Request for Bid

00270.6.1 Declared Exceptions to RFB Requirements

An exception is any variation from an express RFB requirement. Declare all exceptions, whether commercial or technical in nature, in Table 00370.6.1. Provide specific exceptions and accurately reference the article number to which each exception applies. Exceptions of a general nature or that refer to your standard specifications or terms are not acceptable and may result in Purchaser rejecting your bid without prior notice.

00270.6.2 Declared Clarifications to RFB Requirements

A clarification is the means by which you offer to meet an RFB requirement if the RFB does not identify the specific means by which the RFB requirement must be met. Declare any clarifications, whether commercial or technical in nature, in Table 00370.6.2. Reference the article number to which each clarification applies.

00270.7 Bid Attachments

List any supplemental documents included in your bid in Article 00370.7.

00270.8 Declarations

Indicate "Yes" in Article 00370.8 to confirm you have familiarized yourself with the conditions affecting the Work. If you indicate "No," declare an exception in accordance with Article 00270.6.

00270.9 Nondiscrimination

All entities contracting with the Purchaser agree to abide by and to take affirmative action when necessary to ensure compliance with the nondiscrimination clauses set out below, and agree to show proof of non-discrimination upon request and to post in conspicuous places available to all associate agents and their employees. In the event of non-compliance with nondiscrimination clauses, or with provisions of Executive Orders 11141 (age), 11246, 11375 (women), 12086 (Vietnam veterans), 11478 (federal employees), 11625 (minority business) 11701 (veterans), Title 41, Chapter 60 (handicapped) and specifically the handicapped affirmative action clause in Section 60-741.6.9 of OFCCP Rules, and any and all other federal laws prohibiting discrimination, contracts may be canceled, terminated, or suspended in whole or in part by the Purchaser.

The Bidder shall execute the specified Nondiscrimination Certificate (see Section 00672.3) agreeing that, if awarded the Subcontract, he/she shall not discriminate against any Sub-subcontractor, employee, or applicant for employment on the grounds of race, color, national origin or sex, in accordance with the citations listed in the above paragraph; and shall require the execution of such a certificate for each Sub-

subcontractor prior to award of any subcontract with the further requirement that each subcontractor shall include identical requirements in any lower tier subcontracts which might in turn be made. FAILURE TO EXECUTE AND SUBMIT SUCH CERTIFICATE WITH THE BID MAY CAUSE THE BID TO BE REJECTED AS NON-CONFORMING. The successful Bidder and all Sub-subcontractors under the general contract shall maintain copies of their payrolls and all subcontracts for each weekly payroll period for the life of the construction and for a period of **SEVEN (7) YEARS** after final release and payment is made by the Purchaser to the contractor.

00270.10 Equal Business Opportunity Program (EBO)

The Bidder must complete and return the Equal Business Opportunity Program Compliance Form included in Section 00672.4 of this RFB.

00370 – Commercial Bid Form (13 pages)



00370 - Commercial Bid Form

Bidder should refer to Section 00270, Instructions to Bidders, when completing this Bid Form. Bidder shall complete this form entirely and return it with Bidder's Bid.

00370.1 Bid Submitted by	Bidder Response Column
Company Name	
Mailing Address/Number, Street	
Mailing Address/State, Zip Code	
Country	
Taxpayer ID Number (or EIN)	
Bidder's Bid Date	
Bidder's Bid No.	

00370.2 General Bid Parameters
Bidder is providing the information defined by the articles comprising Section 00270, INSTRUCTIONS TO BIDDERS, in the corresponding fields of this Section 00370, COMMERCIAL BID FORM.

00370.2.1 Bidder's Contact Information	Bidder Response Column
Bidder's Representative Name	
Title	
Mailing Address/Number, Street	
Mailing Address/City	
Mailing Address/State, Zip Code	
Delivery Address/Number, Street	
Delivery Address/State, Zip Code	
Country	
Email Address	
Phone Number () - ()	
Mobile Phone Number () - ()	
Fax Number () - ()	

Business Interruption Plan
 Confirm that Bidder maintains a Business Interruption/Disaster Recovery Plan that documents how Bidder will respond to disaster or pandemic to help minimize impact - **Yes/No** If Yes, plan should be submitted with RFB.

00370.2.2 Addenda to Request for Bid			Bidder Response Column
Bidder acknowledges receipt and inclusion of the following Addenda to the RFB - Yes/No			Received and Incorporated
	Addenda Number	Date Issued	

00370.3 Bid Pricing Information

00370.3.1 Bid Prices	See Attached Pricing Table(s) [Bidder to List Tables Used]
-----------------------------	---

00370.4 Supplemental Bid Information
 Bidder provides the following information to supplement the Bidder's bid pricing.

00370.4.1 Company Status	Bidder Response Column
Bidder's company status is: (i.e. partnership, individual owned, joint venture, corporation, etc.)	
in State of	
in Country of	

00370.4.2 Contractor License	Bidder Response Column
Bidder certifies that it is licensed, as required, to engage in the RFB Work scope in the State/Province/Country the RFB Work is to be performed. - Yes/No	
1st License Title	
in State/Province of	
License Number	
2nd License Title	
in State/Province of	
License Number	
00370.4.3 Not Used	

00370.4.4 Bid Validity Duration	Bidder Response Column
Bidder's bid is valid for acceptance by the Purchaser for a period of 180 days from the bid due date. - Yes/No	
If no, Bidder's bid is valid for indicated days from bid due date. - No. Days	

00370.4.5 Firm Non-Escalatable Pricing	Bidder Response Column
All of Bidder's prices herein bid are firm and are non-escalatable. - Yes/No If No, explanation is included as an Exception.	

00370.4.6 Taxes	Bidder Response Column
Bidder's prices included herein are in accordance with Article 00571.6 Taxes. - Yes/No If No, explanation is included as an Exception.	

00370.4.7 Work at Jobsite	Bidder Response Column
Bidder's source of craft labor to be utilized in the performance of the Work is - Open-Shop/Merit-shop/Union-shop	
If applicable, identify the local union(s) used for hiring craft labor: 1st Local Union Name	
Address/Number, Street	
Address/City, State, Zip Code	
Phone	
Email	
2nd Local Union Name	
Address/Number, Street	
Address/City, State, Zip Code	
Phone	
Email	
Bidder has accounted for all Jobsite existing and controlling conditions and limitations which may affect the Work performance and the Bidder's Bid. - Yes/No If No, explanation is included in Exception.	
Bidder proposes that it will perform all the Work at the Jobsite with its own forces. - Yes/No	
Bidder has indicated proposed sub-subcontracted Work in attached Table 00370.4.7. - Yes/No	
Bidder has provided proposed Small Business/Minority/Disadvantaged Entrepreneur Participation Plan with its bid. - Yes/No	

00370.5 Schedule Compliance	
Bidder agrees to meet the schedule dates indicated in the RFB documents: - Yes/No If No, explanation is included in Exception.	
If No, Bidder has completed and submitted an attached alternative summary level schedule: - Yes/No	

00370.6 Compliance with Request for Bid	
NOTE: A bid based on Bidder's standard terms and conditions will not be considered. The bid must address specific exceptions, if any, to Purchaser's terms and conditions.	
Bidder certifies that its bid complies with all RFB commercial and technical requirements without exception and clarification. - Yes/No	

00370.6.1 Exceptions	
Bidder certifies that its bid complies with all RFB commercial and technical requirements except for the following:	Bidder Response Column
Bid is based on acceptance of all commercial requirements of this RFB. - Yes/No	
If No, all Commercial Exceptions have been accurately defined and identified as "Commercial Exceptions" on the Purchaser provided and Bidder attached Exceptions Form: - Yes/No	
Bid is based on acceptance of all technical requirements of this RFB. - Yes/No	
If No, all Technical Exceptions have been accurately defined and identified as "Technical Exceptions" on the Purchaser provided and Bidder attached Exceptions Form. - Yes/No	
00370.6.2 Clarifications	
Bidder certifies that its bid complies with all RFB commercial and technical requirements without clarification. - Yes/No	
If No, all Commercial Clarifications have been accurately defined and identified as "Commercial Clarifications" on the Purchaser provided and Bidder attached Clarification Form. - Yes/No	
If No, all Technical Clarification have been accurately defined and identified as "Technical Clarifications" on the Purchaser provided and Bidder attached Clarification Form. - Yes/No	
00370.7 Bid Attachments	
In addition to this Commercial Bid Form and Tables indicated herein, the Bidder's Bid contains supplemental information and details attached to this bid consisting of the following:	Bidder Response Column
(Attachment 1)	
(Attachment 2)	
(Attachment 3)	
(Attachment 4)	
(Attachment 5) (Add additional lines as needed)	
00370.8 Declarations	
The Bidder declares that it has familiarized itself with the conditions affecting the Work. The Bidder also declares that only the persons or firms interested in the bid as principal or principals are named herein; that no other persons or firms have any interest in this bid or in the Subcontract to be entered into; that this bid is made without connection with any person, company, or party likewise submitting a bid; and that it is in all respects for and in good faith, without collusion or fraud. - Yes/No	
If written notice of acceptance of this bid is delivered to the Bidder within "Bid Validity" days after the date set for receipt of bid, or any time thereafter before the bid validity expires, the Bidder will, within 5 days after receipt of a formal Subcontract for signature, exercise and deliver to Purchaser a signed Subcontract in the form provided by the Purchaser in accordance with the documents provided herein. - Yes/No	

Bidder Authorized Signature:

Table 00370.3.1 - Unit Price Bid Form

Bidder should refer to Section 00270, Instructions to Bidders, when completing this Bid Form. Bidder shall complete this form entirely and return it with Bidder's Bid.					
Submitted by: (Company Name)					
00370.3 Bid Pricing Information					
00370.3.1 Unit Pricing					
Bidder proposes to complete the RFB Work based on firm, fixed, unit prices (US dollars), which prices multiplied by the final Work quantities would represent the full consideration to Bidder for its complete and satisfactory performance of the Work in compliance with all the terms and conditions of the RFB Documents. The Unit Prices in this Table include the cost of all the work which is required or implied by the RFB documents or which may be inferred therefrom, and which is customarily provided in furnishing a complete and finished work item of its kind. Further, any and all alterations, modifications, and adjustments to the work item, which is reasonably foreseeable or customarily encountered in providing and installing equipment, material, and services of the work item kind, will be performed without additional compensation.					
In the event of a Purchaser-approved change in the scope of Work for which a unit price from this Table is not applicable, as determined by the Purchaser, the Subcontractor shall provide a new unit price for review and acceptance by the Purchaser. Subcontractor shall provide all information requested by the Purchaser to substantiate the value of the new unit price.					
00370.3.1.1 Unit Prices				Bidder Response Columns	
Item Number	Item Description	Unit of Measure	Estimated Quantity	Unit Price	Extension Price
Wolf River Interceptor Rehab (Option A)					
Manholes					
00001-6.01	GPS Coordinates of Manhole Cover	Each	2	\$ -	\$ -
00001-6.02	Manhole Assessment and Certification Program (MACP) Level 2 Inspection - with 3D Scan	Each	2	\$ -	\$ -
00001-6.03	Removal of All Manhole Steps	Each	20	\$ -	\$ -
Lining / Coating Options					
09910-7.01.1	CIPP 96-INCH	LF	1,350	\$ -	\$ -
09910-7.02.1	Bypass Pumping for CIPP	LS	1	\$ -	\$ -
09910-7.03	Manhole Modification	Each	2	\$ -	\$ -
09920-6.04	Site Preparation and Restoration	LS	1	\$ -	\$ -
09920-6.07	Heavy Cleaning 96-inch Pipe	LF	1,350	\$ -	\$ -
9930.01	Special Structure for Bypass	LS	1	\$ -	\$ -
Sonar / CCTV Inspection					
00004-6.01	Post CCTV Inspection	LF	1,350	\$ -	\$ -
Miscellaneous					
	100% Performance and Payment Bonds	Lot	1	\$ -	\$ -
Wolf River Interceptor Rehab (Option A)- Total Estimated Unit Price Value					\$ -

Table 00370.3.1 - Unit Price Bid Form

Bidder should refer to Section 00270, Instructions to Bidders, when completing this Bid Form. Bidder shall complete this form entirely and return it with Bidder's Bid.					
Submitted by: (Company Name)					
00370.3 Bid Pricing Information					
00370.3.1 Unit Pricing					
Bidder proposes to complete the RFB Work based on firm, fixed, unit prices (US dollars), which prices multiplied by the final Work quantities would represent the full consideration to Bidder for its complete and satisfactory performance of the Work in compliance with all the terms and conditions of the RFB Documents. The Unit Prices in this Table include the cost of all the work which is required or implied by the RFB documents or which may be inferred therefrom, and which is customarily provided in furnishing a complete and finished work item of its kind. Further, any and all alterations, modifications, and adjustments to the work item, which is reasonably foreseeable or customarily encountered in providing and installing equipment, material, and services of the work item kind, will be performed without additional compensation.					
In the event of a Purchaser-approved change in the scope of Work for which a unit price from this Table is not applicable, as determined by the Purchaser, the Subcontractor shall provide a new unit price for review and acceptance by the Purchaser. Subcontractor shall provide all information requested by the Purchaser to substantiate the value of the new unit price.					
00370.3.1.1 Unit Prices				Bidder Response Columns	
Item Number	Item Description	Unit of Measure	Estimated Quantity	Unit Price	Extension Price
Wolf River Interceptor Rehab (Option B)					
Manholes					
00001-6.01	GPS Coordinates of Manhole Cover	Each	2	\$ -	\$ -
00001-6.02	Manhole Assessment and Certification Program (MACP) Level 2 Inspection - with 3D Scan	Each	2	\$ -	\$ -
00001-6.03	Removal of All Manhole Steps	Each	20	\$ -	\$ -
Lining / Coating Options					
09920-6.01.2	Geopolymer	LF	1,350	\$ -	\$ -
09920-6.02.2	Bypass Pumping for Geopolymer	LS	1	\$ -	\$ -
09920-6.04	Site Preparation and Restoration	Each	1	\$ -	\$ -
09920-6.06	Additional Leak Stop Grouting	HR	50	\$ -	\$ -
09920-6.07	Heavy Cleaning 96-inch Pipe	LF	1,350	\$ -	\$ -
9930.01	Special Structure for Bypass	LS	1	\$ -	\$ -
Sonar / CCTV Inspection					
00004-6.01	Post CCTV Inspection	LF	1,350	\$ -	\$ -
Miscellaneous					
	100% Performance and Payment Bonds	Lot	1	\$ -	\$ -
Wolf River Interceptor Rehab (Option B)- Total Estimated Unit Price Value					\$ -

Table 00370.3.1 - Unit Price Bid Form

Bidder should refer to Section 00270, Instructions to Bidders, when completing this Bid Form. Bidder shall complete this form entirely and return it with Bidder's Bid.					
Submitted by: (Company Name)					
00370.3 Bid Pricing Information					
00370.3.1 Unit Pricing					
Bidder proposes to complete the RFB Work based on firm, fixed, unit prices (US dollars), which prices multiplied by the final Work quantities would represent the full consideration to Bidder for its complete and satisfactory performance of the Work in compliance with all the terms and conditions of the RFB Documents. The Unit Prices in this Table include the cost of all the work which is required or implied by the RFB documents or which may be inferred therefrom, and which is customarily provided in furnishing a complete and finished work item of its kind. Further, any and all alterations, modifications, and adjustments to the work item, which is reasonably foreseeable or customarily encountered in providing and installing equipment, material, and services of the work item kind, will be performed without additional compensation.					
In the event of a Purchaser-approved change in the scope of Work for which a unit price from this Table is not applicable, as determined by the Purchaser, the Subcontractor shall provide a new unit price for review and acceptance by the Purchaser. Subcontractor shall provide all information requested by the Purchaser to substantiate the value of the new unit price.					
00370.3.1.1 Unit Prices				Bidder Response Columns	
Item Number	Item Description	Unit of Measure	Estimated Quantity	Unit Price	Extension Price
Wolf River Interceptor Rehab (Option C)					
Manholes					
00001-6.01	GPS Coordinates of Manhole Cover	Each	2	\$ -	\$ -
00001-6.02	Manhole Assessment and Certification Program (MACP) Level 2 Inspection - with 3D Scan	Each	2	\$ -	\$ -
00001-6.03	Removal of All Manhole Steps	Each	20	\$ -	\$ -
Lining / Coating Options					
09920-6.01.3	Epoxy	LF	1,350	\$ -	\$ -
09920-6.02.3	Bypass Pumping for Epoxy	LS	1	\$ -	\$ -
09920-6.04	Site Preparation and Restoration	LS	1	\$ -	\$ -
09920-6.06	Additional Leak Stop Grouting	HR	50	\$ -	\$ -
09920-6.07	Heavy Cleaning 96-inch Pipe	LF	1,350	\$ -	\$ -
9930.01	Special Structure for Bypass	LS	1	\$ -	\$ -
Sonar / CCTV Inspection					
00004-6.01	Post CCTV Inspection	LF	1,350	\$ -	\$ -
Miscellaneous					
	100% Performance and Payment Bonds	Lot	1	\$ -	\$ -
Wolf River Interceptor Rehab (Option C)- Total Estimated Unit Price Value					\$ -

Table 00370.3.1 - Unit Price Bid Form

Bidder should refer to Section 00270, Instructions to Bidders, when completing this Bid Form. Bidder shall complete this form entirely and return it with Bidder's Bid.					
Submitted by: (Company Name)					
00370.3 Bid Pricing Information					
00370.3.1 Unit Pricing					
Bidder proposes to complete the RFB Work based on firm, fixed, unit prices (US dollars), which prices multiplied by the final Work quantities would represent the full consideration to Bidder for its complete and satisfactory performance of the Work in compliance with all the terms and conditions of the RFB Documents. The Unit Prices in this Table include the cost of all the work which is required or implied by the RFB documents or which may be inferred therefrom, and which is customarily provided in furnishing a complete and finished work item of its kind. Further, any and all alterations, modifications, and adjustments to the work item, which is reasonably foreseeable or customarily encountered in providing and installing equipment, material, and services of the work item kind, will be performed without additional compensation.					
In the event of a Purchaser-approved change in the scope of Work for which a unit price from this Table is not applicable, as determined by the Purchaser, the Subcontractor shall provide a new unit price for review and acceptance by the Purchaser. Subcontractor shall provide all information requested by the Purchaser to substantiate the value of the new unit price.					
00370.3.1.1 Unit Prices				Bidder Response Columns	
Item Number	Item Description	Unit of Measure	Estimated Quantity	Unit Price	Extension Price
Wolf River Interceptor Rehab (Option D)					
Manholes					
00001-6.01	GPS Coordinates of Manhole Cover	Each	2	\$ -	\$ -
00001-6.02	Manhole Assessment and Certification Program (MACP) Level 2 Inspection - with 3D Scan	Each	2	\$ -	\$ -
00001-6.03	Removal of All Manhole Steps	Each	20	\$ -	\$ -
Lining / Coating Options					
09920-6.01.4	Polyurethane	LF	1,350	\$ -	\$ -
09920-6.02.4	Bypass Pumping for Polyurethane	LS	1	\$ -	\$ -
09920-6.04	Site Preparation and Restoration	LS	1	\$ -	\$ -
09920-6.06	Additional Leak Stop Grouting	HR	50	\$ -	\$ -
09920-6.07	Heavy Cleaning 96-inch Pipe	LF	1,350	\$ -	\$ -
9930.01	Special Structure for Bypass	LS	1	\$ -	\$ -
Sonar / CCTV Inspection					
00004-6.01	Post CCTV Inspection	LF	1,350	\$ -	\$ -
Lining / Coating Options					
	100% Performance and Payment Bonds	Lot	1	\$ -	\$ -
Wolf River Interceptor Rehab (Option D)- Total Estimated Unit Price Value					\$ -

Table 00370.6.1 - Exceptions Form

Bidder should refer to Section 00270, Instructions to Bidders, when completing this Form.

Bid Submitted by: (Company Name)

00370.6.1 Exceptions

The Bidder's specific Exceptions herein itemized and included with the bid represent an exhaustive list of any and all explicit variations or deviations from the requirements of the RFB documents. Bidder confirms that otherwise, it is the intent of Bidder's bid that the Work will be performed in strict accordance with the requirements of the RFB documents.

00370.6.1.1 Commercial Exceptions

Count	Reference Article	Stated Commercial Exception
CE1		
CE2		
CE3		
CE4		
CE5		
CE6		
CE7		
CE8		
CE9		

00370.6.1.2 Technical Exceptions

Count	Reference	Stated Technical Exceptions
TE1		
TE2		
TE3		
TE4		
TE5		
TE6		
TE7		
TE8		
TE9		
TE10		
TE11		
TE12		
TE13		
TE14		
TE15		
TE16		
TE17		
TE18		
TE19		
TE20		

Table 00370.6.2 - Clarifications Form

Bidder should refer to Section 00270, Instructions to Bidders, when completing this Form.

Bid Submitted by: (Company Name)

00370.6.2 Clarifications

All of Bidder's Clarifications herein itemized and included with the bid **do not** constitute explicit variation or deviation from performance of the Work by the Bidder in strict accordance with the requirements of RFB documents.

00370.6.2.1 Commercial Clarifications

Count	Reference Article	Stated Commercial Clarification
CC1		
CC2		
CC3		
CC4		
CC5		
CC6		
CC7		
CC8		
CC9		

00370.6.2.2 Technical Clarifications

Count	Reference	Stated Technical Clarification
TC1		
TC2		
TC3		
TC4		
TC5		
TC6		
TC7		
TC8		
TC9		
TC10		
TC11		
TC12		
TC13		
TC14		
TC15		
TC16		
TC17		
TC18		
TC19		
TC20		

00370.7 Schedule Compliance
State any exceptions in 00370.6.1.

00370.7.1 Construction Milestone Completion Dates and Applicable Liquidated Damages

Item	Milestone Description	Construction Milestone Completion Date	*LDs Apply?	Bidder Complies? (Yes/No)
1	Completion of all Work under Subcontract 71.0397	240 calendar days after Notice to Proceed	Yes	

*LD indicates that completion of the Work after the "Construction Milestone Completion Date" is subject to liquidated damages per applicable Articles of Section 00571.

*Note Subcontractor performance will directly impact future procurements for the SARP10 Program, schedule is critical and must be maintained.

00370.8 Schedule of Submittals							Bidder Agrees? Yes/No
Effective Date: TBD							
The following are post-award Subcontract submittals. This list is not all-inclusive. The RFB documents contain submittal requirements that are not included in this list. It will, however, remain the successful Bidder's responsibility to comply with submittal requirements whether or not the submittal is included in the following list:							
If Bidder does not agree, state an exception in 00370.6.1.							
Item	Reference Section	Submittal Item	Submittal Dates			Due Date	
			Calendar Days	Event			
00370.8.1 Commercial Submittals							
C01	None	Executed Subcontract in the form provided by the Purchaser	5	After	Receipt of Subcontract for Signature		
C02	00571	Payment Estimate Breakdown	10	After	Effective Date and Prior to First Payment with monthly updates		
C03	00571	Security Instruments	10	After	Effective Date		
C04	00572	Lien Waivers and Report of Disadvantaged Business Enterprise Participation Form		With	Each Invoice		
C05	00572	Final Lien Waivers from Subcontractor and Sub-subcontractors and Sub-subcontractors subcontracts and Report of Disadvantaged Business Enterprise Participation Form		With	Final Invoice		
C06	00571	Final Payment Invoice and Report of Disadvantaged Business Enterprise Participation Form	45	After	Issuance of the Notice Of Final Completion and Acceptance		
C07	00572	Contractor Licenses	14	Before	Mobilization Onsite		
C08	00572	Written Notice and Supporting Documentation, of all Claims	5	After	Occurrence of Event Giving Rise to the Claim		
C09	00572	Insurance Certificates for Purchaser Approval		Prior to	Mobilization		
C10	00572	Initial Issue Subcontractor's Work Execution Schedule	30	After	Effective Date		
C11	00571	Subcontractor Actual Man-hours Expended and Quantities Installed	Weekly	After	Mobilization Onsite		
C12	00575	Subcontractor's Daily Report	Daily	After	Mobilization Onsite		
C13	00575	Signed Daily Reports		Daily	After Mobilization Onsite		
C14	00575	Weekly Coordination Meeting Agenda Input	Weekly	Prior to	Weekly Coordination Meeting		
C15	00575	Subcontractor's Safety, Health and Accident Prevention Program		Prior to	Mobilization Onsite		
C16	00575	Subcontractor's Hazardous Waste Project Health and Safety Plan		Prior to	Mobilization Onsite		
C17	00575	Safety and Health Representative Resume		Prior to	Assignment and Mobilization		
C18	00575	Verification of meeting Hazardous Waste Requirements of 29CFR1910.120	5	Prior to	Mobilization Onsite		
C19	00575	Hazardous Materials Documentation		With	Each Hazmat Shipment		
C20	00575	Safety and Health Records	Monthly	After	Mobilization Onsite		
C21	00575	Evidence that Jobsite Personnel have Passed Drug Testing	10	Prior to	Mobilization Onsite		
C22	Loss Control Manual	Fall Protection Plan	5	Prior to	Starting Work Operations		

00370.8 Schedule of Submittals							Bidder Agrees? Yes/No
Effective Date: TBD							
The following are post-award Subcontract submittals. This list is not all-inclusive. The RFB documents contain submittal requirements that are not included in this list. It will, however, remain the successful Bidder's responsibility to comply with submittal requirements whether or not the submittal is included in the following list:							
If Bidder does not agree, state an exception in 00370.6.1.							
Item	Reference Section	Submittal Item	Submittal Dates			Due Date	
			Calendar Days	Event			
C23	Loss Control Manual	Chemical Hazard Communication Plan, as applicable	5	Prior to	Mobilization Onsite		
C24	Loss Control Manual	Substance Abuse Program	5	Prior to	Mobilization Onsite		
C25	SRF	W-9 of Subcontractor and Sub-subcontractors also include Contact Information for each including email, phone number, and address		With	Bid		
C26	00672.3	Certificate of Nondiscrimination for Subcontractor and Sub-subcontractors		With	Bid		
C27	00672.4	Equal Business Opportunity Program Compliance Form for Subcontractor and Sub-subcontractors		With	Bid		
C28	00672.6	Certification Regarding Debarment Subcontractor and Sub-subcontractors		With	Bid		
C29	00672.6	Certification Regarding Equal Employment Opportunity for Subcontractor and Sub-subcontractors		With	Bid		
C30	SRF	M/WBE Certificates for both Subcontractor and Sub-subcontractors as applicable		With	Bid		
C31	00170.4	Bid Bond		With	Bid		
C32	SRF	Employee Rights under the Davis-Bacon Act Poster (English and Spanish)		Posted	All Sites to be easily accessed/viewed and protected from weather		
C33	SRF	WH-1321 poster		Posted	All Sites to be easily accessed/viewed and protected from weather		
C34	SRF	Wage Decision		Posted	All Sites to be easily accessed/viewed and protected from weather		

00571 - Supplementary Terms and Conditions

00571.1 Notices and Correspondence

The parties agree to send all notices arising out of or related to this Subcontract by one of the following methods: (a) personal delivery; (b) certified mail with return receipt; (c) nationally recognized overnight mail or courier service, with delivery receipt requested; or (d) email. The parties may send routine correspondence by email or first class mail, each without confirmation of receipt. The parties agree to address notices and correspondence as indicated in this article. Subcontractor agrees that delivery of a notice or of correspondence by Purchaser to Subcontractor's at the jobsite constitutes personal delivery.

Electronic Technical Correspondence

Addressed to Purchaser:

To: Brad Davis
DavisBJ@bv.com
Cc: Gary Older
OlderGS@bv.com

Addressed to Subcontractor:

To: [[name]]
[[email address]]
Cc: [[name]]
[[email address]]

Non-Electronic Technical Correspondence

Addressed to Purchaser:

Overland Contracting Inc.
3485 Poplar Avenue, Suite 230
Memphis, TN 38111
Attention: Brad Davis
194677.71.0397

Addressed to Subcontractor:

[[subcontractor entity]]
[[street address]]
[[city, state, zip code]]
Attention: [[name]]
194677.71.0397

Electronic Commercial Correspondence (excluding invoices)

Addressed to Purchaser:

To: Ginny Dorsey
Dorsey@bv.com

Addressed to Subcontractor:

To: [[name]]
[[email address]]
Cc: [[name]]
[[email address]]

Non-Electronic Commercial Correspondence (excluding invoices)

Addressed to Purchaser:

Overland Contracting Inc.
8400 Ward Parkway
Kansas City, MO 64114
Attention: Ginny Dorsey
194677.71.0397

Addressed to Subcontractor:

[[subcontractor entity]]
[[street address]]
[[city, state, zip code]]
Attention:
194677.71.0397



Electronic Invoices

Subcontractor will submit invoices via email to sarp10invoices@bv.com. Subcontractor shall utilize the AIA form, available upon request. Invoices will be reviewed, and either approved or returned to Subcontractor for correction. The Black & Veatch Project Manager will forward invoices to Black & Veatch Accounts Payable, once they are approved.

All Subcontractor Invoice Submittals:

To: Overland Contracting, Inc.

sarp10invoices@bv.com

Attention: BVAP

194677.71.0397

00571.2 Not Used

00571.3 Payment Terms

The following payment terms shall apply in addition to the corresponding provisions contained in Article 00572.4 Invoicing and Payment.

The Parties will meet each month at an agreed time in order to determine the quantity of materials used and man-hours expended during the invoice period. The Parties will use the field progress measurement system to calculate that month's payment total by adding the Subcontract unit price totals based on actual Work completed.

00571.4 Security Instruments

Subcontractor shall give Purchaser separate performance and payment bonds in the format of AIA Document 312 - 2010 Performance Bond and Payment Bond, each in the amount of the Subcontract Price. Subcontractor shall submit the bonds to Purchaser by the due date specified in the Article titled "Schedule of Submittals and Applicable Liquidated Damages". The bonding company must be licensed to bond in the state in which the Project is located and must be rated "A" or better by A.M. Best and included in the Department of the Treasury's Listing of Approved Sureties (Department Circular 570).

00571.5 Liquidated Damages

00571.5.1 General

Subcontractor's failure to meet the requirements identified in this Article 00571.5 will cause Purchaser to incur harm that will be very difficult to ascertain with certainty. The Parties therefore agree the liquidated damages specified in this Article 00571.5 represent a reasonable estimate of Purchaser's harm and are not intended as a penalty. Subcontractor's obligation to pay liquidated damages for breach of one specified requirement does not relieve Subcontractor of its obligation to pay liquidated damages for breach of another specified requirement. Subcontractor's payment of liquidated damages for breach of the specified requirement is Purchaser's sole and exclusive remedy with regard to Subcontractor's breach of that requirement, except for any other express remedies stated in the Subcontract. If Purchaser terminates the Subcontract for cause, liquidated damages will cease to accrue after the termination date and Subcontractor's remaining liability will be calculated in accordance with Article 00572.17.

00571.5.2 Not Used

00571.5.3 Construction Milestone Dates

Each construction milestone subject to liquidated damages for late completion is listed in the article titled "Construction Milestone Completion Dates and Applicable Liquidated Damages". If all portions of the Work comprising the construction milestone do not meet the Subcontract requirements on the construction milestone completion date, liquidated damages will accrue for each failure as shown below.

Beginning on the first calendar day after the specified construction milestone completion date for each construction milestone and continuing until the construction milestone is completed, delay liquidated damages will be assessed at the rate of five hundred (\$500) dollars per calendar day.

00571.6 Taxes

Subcontractor shall pay all payroll and other related employment compensation taxes for Subcontractor's employees, federal, state and other taxes which may be assessed on Subcontractor's income from the Project, engineering and business license costs (collectively, the "Subcontractor Taxes"). Subcontractor shall administer and pay all sales, use, gross receipts and excise taxes (collectively, the "Project Taxes"). Subcontract price includes Subcontractor Taxes and all Project Taxes. Purchaser will not be responsible for any additional charges related to tax that were not included as part of the Subcontract Price. Where applicable, Purchaser shall furnish to Subcontractor a certificate complying with state and local governmental laws, regulations and ordinances identifying any components of the Work to be considered exempt from the Project Taxes. Subcontractor shall cooperate with Purchaser to establish appropriate procedures and minimize the amount of such taxes to the extent reasonable and practical. Subcontractor is responsible for all property taxes on the construction equipment; Owner is responsible for property taxes on all other items incorporated into the project. Subcontractor shall notify Purchaser, and Purchaser shall have the right to review prior to Subcontractor's response to such document, of any correspondence with a federal or local taxing authority as it relates to sales and use, gross receipts, or excise taxes.

00572 - General Terms and Conditions

00572.1 Definitions

The terms below have the following definitions when used in this Subcontract:

"Applicable Laws" means all laws, statutes, regulations, codes, rules, treaties, ordinances, judgments, permits, decrees, approvals, interpretations, injunctions, writs, orders, or other legal requirements of a governmental body entitled to exercise any administrative, executive, judicial, legislative, police, regulatory or taxing power and having jurisdiction over the jobsite or performance of the Work.

"Claims" means claims, actions, suits, liabilities, demands, damages, losses, costs, expenses (including reasonable attorneys' fees), impacts to price, impacts to schedule, awards, fines and judgments, of every kind and nature.

"Consent Decree" means the negotiated plan between Owner, Department of Justice, Environmental Protection Agency, Tennessee department of Environment and Conservation, and the Tennessee Clean Water Network that requires Owner to develop and implement plans to improve its wastewater systems.

"Final Completion" means: (a) the Work is complete and complies with the requirements of this Subcontract; and (b) Subcontractor has fulfilled all of its obligations under this Subcontract except obligations that survive completion of the Work.

"Indemnified Parties" means Owner and its officials, Purchaser, Purchaser's engineer, and the parent companies, related companies, affiliated companies, subsidiaries, successors, and assigns of each, including the shareholders, officers, directors, partners, employees, and agents of each of the above firms. "Indemnified Parties" does not include Subcontractor or any Sub-subcontractor.

"Notice to Proceed" means to written notice provided by Purchaser to Subcontractor releasing Subcontractor to proceed with all or part of the Work.

"Owner" means the City of Memphis, Tennessee.

"Program Manager" means Black & Veatch Corporation or Overland Contracting Inc. (OCI).

"Purchaser" means the party so identified in the Subcontract Agreement.

"SARP10 Program Office" 3485 Poplar Avenue, Suite 230, Memphis, TN 38111.

"Subcontract" means the agreement between Purchaser and Subcontractor consisting of: (a) the Subcontract Agreement; (b) the documents listed in the Subcontract Agreement; (c) written Subcontract revisions; (d) attachments, appendices and exhibits to the Subcontract documents; (e) documents expressly incorporated by reference into the Subcontract; and (e) any requirements that can be reasonably inferred from any of the foregoing.

"Subcontract Agreement" means the Subcontract form executed by Purchaser and Subcontractor.

"Subcontractor" means the party so identified in the Subcontract Agreement.

"Sub-subcontractor" means any party, at any tier, having an agreement with Subcontractor or with a Sub-subcontractor, to perform a portion of the Work.

"Work" means that which Subcontractor is to perform or provide under this Subcontract.

00572.2 Interpretation

00572.2.1 This Subcontract is the complete and final agreement between the parties relating to the Work. All prior or contemporaneous negotiations and agreements relating to the Work are superseded by this Subcontract. Exceptions or terms submitted by Subcontractor in the course of accepting this Subcontract are void.

00572.2.2 Provisions of this Subcontract that contemplate performance or obligations subsequent to completion or termination of the Work or contain waivers or limitations of liability will survive such completion or termination. Termination of the Work will not affect the rights and obligations that arose before termination.

00572.2.3 If any provision of this Subcontract is held to be unenforceable, the remaining provisions of this Subcontract will remain in effect.

00572.3 Subcontractor's Status

Subcontractor is an independent contractor in the performance of the Work. Subcontractor is solely responsible for the means, methods, sequences, procedures, and safety precautions used or adopted by Subcontractor and any Sub-subcontractor in the performance of the Work. Except as provided in Article 00574.2 and 00574.3, Subcontractor has sole authority and responsibility to employ, manage, discharge, and otherwise control its employees.

00572.4 Invoicing and Payment

00572.4.1 Subcontractor shall submit invoices to Purchaser with all documentation required to be submitted with the invoice. Each invoice must be itemized by the Subcontract line number. Each invoice must also clearly show the Subcontract number, the invoice number, the billing period (if applicable), the invoiced amount, retention (if applicable), and the net amount due. The final invoice must contain a copy of Purchaser's notice of Final Completion.

00572.4.2 Subcontractor agrees to provide additional itemization of the Subcontract price as Purchaser reasonably requests. If payment to Subcontractor will be on a time and material basis or a unit price basis, or if Subcontractor files a Claim under Article 00572.13, Subcontractor shall furnish Purchaser complete breakdowns and supporting information in the detail required by Purchaser to verify the accuracy of the invoiced or claimed amounts. Purchaser or Purchaser's designee may audit the aforementioned records at Purchaser's expense.

00572.4.3 Purchaser will withhold five percent retention from all invoices except the final invoice. Payment by Purchaser does not: (a) constitute approval or acceptance of any portion of the Work; (b) waive any of Purchaser's rights; or (c) relieve Subcontractor from responsibility or liability arising out of or related to this Subcontract. Acceptance by Subcontractor of final payment constitutes a release and waiver of all Claims by Subcontractor against Indemnified Parties.

00572.4.4 Purchaser may withhold or set-off amounts due under this Subcontract on account of Claims arising out of or related to Subcontractor's breach or reasonably anticipated breach of this Subcontract.

00572.4.5 Once Work that has undergone specified QA/QC is submitted, reviewed and approved by the Program Manager, the Subcontractor's invoice will be submitted along with the Program Manager's next invoice to the Owner. The Program Manager's invoice is typically submitted during the second week of each month for work performed during the previous month. Typical payment from the Owner to the Program Manager is anticipated to be forty five (45) calendar days upon Owner's acceptance of invoice, and the Program Manager will cause the Purchaser to pay the Service Contractor within two weeks of Program Manager's receipt of payment from the Owner.

00572.5 Schedule

Performance of the Work as scheduled under this Subcontract is of the essence. Subcontractor shall give Purchaser written notice of any delay or anticipated delay within three calendar days after the occurrence of the event giving rise to the delay. Subcontractor's notice must identify the cause of the delay or the anticipated delay and the actions Subcontractor is undertaking to recover from or avoid the delay.

00572.6 Waivers of Lien

As a condition precedent to payment, Subcontractor shall furnish a lien waiver in the form of Article 00672.1 with each invoice except the final invoice. As a condition precedent to payment of the final invoice, Subcontractor shall furnish a lien waiver in the form of Article 00672.2 with the final invoice. If a lien is filed and Subcontractor does not remove or bond around the lien within seven calendar days after receipt of written notice from Purchaser or Owner, Purchaser or Owner may remove the lien. Subcontractor shall reimburse Purchaser or Owner, as applicable, for all costs and expenses incurred by Purchaser or Owner in removing the lien, including reasonable attorneys' fees and court costs.

00572.7 Assignment and Subcontracting

00572.7.1 Subcontractor may not assign all or part of this Subcontract voluntarily, by operation of law, or otherwise, nor may Subcontractor assign any of the money payable under this Subcontract, without obtaining Purchaser's prior written consent.

00572.7.2 Except for the supply of expendable materials and minor components or the supply of a portion of the Work for which a Sub-subcontractor is named in this Subcontract, Subcontractor may not subcontract the Work without first obtaining Purchaser's written consent. In addition, Subcontractor must obtain a safety prequalification for any Sub-subcontractor that will be performing any portion of the Work at the Jobsite, as outlined in Article 00575.9. If Subcontractor subcontracts any portion of the Work, Subcontractor remains responsible for complying with the Subcontract requirements and is liable to Purchaser for the acts and omissions of Sub-subcontractors, including their failure to comply with the requirements of this Subcontract or fulfill the obligations imposed on Subcontractor by this Subcontract, as if the acts and omissions were those of Subcontractor. Purchaser has the right to contact Sub-subcontractors to discuss their progress of the Work.

00572.8 Passage of Title, Risk of Loss, and Delivery

Subcontractor warrants that the Work (excluding Subcontractor-furnished items that are not intended to become a permanent part of the project) will be free of all liens, claims, charges, security interests, encumbrances or defects in title. Title to the Work (excluding Subcontractor-furnished items that are not intended to become a permanent part of the project) will pass to Purchaser upon the earlier of Subcontractor's receipt of payment or delivery of the Work to the jobsite. Subcontractor retains the risk of loss of the Work until Purchaser issues the notice of Final Completion. The terms of delivery have the meanings assigned them in the 2010 edition of the Incoterms published by the International Chamber of Commerce, except as modified in this Subcontract.

00572.9 Final Completion

Subcontractor shall notify Purchaser in writing when Subcontractor believes the Work meets the requirements for Final Completion. Purchaser will inspect the Work within ten calendar days after Purchaser's receipt of Subcontractor's notice. If Purchaser identifies any defective or non-conforming Work, Subcontractor shall correct that Work in accordance with Article 00572.10. Purchaser will issue a notice that Final Completion has been achieved when the Work meets the requirements for Final Completion. Purchaser's issuance of the notice of Final Completion does not relieve Subcontractor of its obligations under this Subcontract.

00572.10 Warranty

00572.10.1 Subcontractor warrants to Purchaser and Owner that the Work: (a) will be new when delivered to the jobsite; (b) will be free from defects in design, material, and workmanship; (c) will comply with Applicable Laws; (d) will comply with the requirements of this Subcontract; and (e) will be fit for the purposes specified. Subcontractor also warrants to Purchaser and Owner that elements of the Work for which this Subcontract does not establish express standards of quality and fitness will comply with good industry practices for the specific application. Subcontractor agrees that Owner may directly enforce the warranties of this Article 00572.10.1.

00572.10.2 Subcontractor shall correct any breach of this warranty within five calendar days after Purchaser gives Subcontractor written notice of the breach. The cost of warranty work and removal or replacement of other work will be at Subcontractor's expense. Subcontractor shall work diligently and without interruption to correct the breach. In the case of emergency where, in the reasonable judgment of Purchaser, delay could result in serious loss or damage to persons or property, Purchaser may correct the defect or nonconformity at Subcontractor's expense.

00572.10.3 The warranty for the Work extends until one year after Final Completion. The warranty applies to all repairs and replacements to the same extent the warranty applies to the original Work. The warranty period for repaired Work or replacements will be extended for a period of one year after the repair or replacement is complete or until the original warranty period expires, whichever occurs later.

00572.10.4 Subcontractor acknowledges that Owner's failure to achieve 100 percent compliance with the Consent Decree requirements may result in the imposition of penalties, costs, and other damages imposed against the Owner and Purchaser. To the extent caused by Subcontractor's failure to perform the Work in accordance with this Subcontract or to the extent caused by the negligence of Subcontractor or any Sub-subcontractor. Subcontractor agrees to pay penalties and costs incurred by Owner and Purchaser under the Consent Decree.

00572.11 Compliance with Laws

00572.11.1 Subcontractor shall comply with all Applicable Laws in effect during its performance of Work, including but not limited to the City of Memphis Prevailing Wage Ordinance, Davis Bacon, the Fair Labor Standards Act, Occupational Safety and Health Administration (OSHA), and the Americans with Disabilities Act (ADA). Subcontractor shall obtain all licenses, permits, and inspections applicable to the Work except for licenses, permits, and inspections identified in this Subcontract as Purchaser's or Owner's responsibility. Subcontractor shall also comply with the USA's Foreign Corrupt Practices Act.

00572.11.2 Purchaser and Subcontractor shall abide by the requirements of 41 CFR §§ 60-1.4(a), 60-4.3(a), 60-300.5(a) and 60-741.5(a). These regulations prohibit discrimination against qualified individuals based on their status as protected veterans or individuals with disabilities, and prohibit discrimination against all individuals based on their race, color, religion, sex, or national origin. Moreover, these regulations require that covered prime contractors and subcontractors take affirmative action to employ and advance in employment individuals without regard to race, color, religion, sex, national origin, protected veteran status or disability.

00572.11.3 Neither party shall engage in any conduct or activity in the performance of this Subcontract that constitutes a conflict of interest under Applicable Laws.

00572.12 Business Practices

00572.12.1 Subcontractor shall uphold the good name and reputation of Purchaser and shall not take any action which is intended to or which causes damage to or discredits Purchaser. Subcontractor shall not:

- (a) offer to give or agree to give any director, officer, employee or agent of any potential client a gift or consideration of any kind as an inducement or reward for: (i) doing or declining to do, or for having done or declined to do, any action in relation to obtaining or executing any contract or (ii) for showing or declining to show any favor or disfavor to any person in relation to any possible project; or
- (b) induce or attempt to induce any officer, servant, or agent of any private or public body to depart from his or her duties to his or her client or, in the case of any officer, servant or agent of a public body, his or her duties to the applicable public body, the applicable body politic, or both.

00572.12.2 Subcontractor shall not engage or employ, on a full, part-time or any other basis during the term of the Prime Agreement and for a period of one year after the termination or expiration, any professional or technical personnel who are or have been at any time during the term of the Prime Agreement in the employ of Owner with the explicit written consent of Owner.

00572.12.3 Nondiscrimination:

(a) Subcontractor certifies and agrees that all persons employed by it, its affiliates, subsidiaries, or holding companies are and will be treated equally without regard to or because of race, creed, color, religion, ancestry, national origin, sexual orientation, sex, age, condition of physical or mental handicap, marital status, or political affiliation, in compliance with all Applicable Laws. Subcontractor shall certify, at Purchaser's request that it is in full compliance with all applicable EEO rules and laws.

(b) Purchaser and Owner reserve the right to investigate any claims of illegal discrimination by Subcontractor and in the event a finding of discrimination is made and upon written notification thereof, Subcontractor shall take all necessary steps to cure and rectify such action to the reasonable satisfaction of Purchaser and Owner. Subcontractor's failure or refusal to do so shall be cause for termination of this Subcontract in accordance with the terms of this Subcontract.

00572.12.4 Purchaser is an affirmative action employer. Accordingly, the parties hereby incorporate by reference the requirements of Executive Order 11246, as amended, and the applicable regulations contained in 41 C.F.R. Parts 60-1 through 60-60; 29 U.S.C. Section 793 and the applicable regulations contained in 41 C.F.R. Part 60-741; 38 U.S.C. Section 4212 and the applicable regulations contained in 41 C.F.R. Part 60-250 and/or 60-300; and 29 C.F.R. Part 471, Appendix A to Subpart A.

00572.12.5 Subcontractor represents and warrants that it has a code of conduct or other set of compliance requirements that is at least as broad as Purchaser's Code of Conduct for Global Business Relationships (refer to Article 00672.9, hereinafter "Code of Conduct"), or that it will comply with Purchaser's Code of Conduct in all dealings that affect Purchaser.

00572.13 Claims

Subcontractor must give written notice, with appropriate supporting documentation, of all Claims for extra compensation or additional time for performance of the Work within three calendar days after occurrence of the event giving rise to the Claim. Subcontractor acknowledges that failure of Subcontractor to give Purchaser notice and appropriate supporting documentation within the required time frame constitutes a waiver of all Claims arising out of or related to the event.

00572.14 Subcontract Revisions and Work Authorizations

00572.14.1 Purchaser may make additions, deletions, reductions in scope, or other changes to the Work. If a proposed change will cause a material increase or decrease in Subcontractor's cost or time for performance, Subcontractor shall so notify Purchaser in writing, accompanied by supporting documentation, within three calendar days after Subcontractor's receipt of Purchaser's notice of change.



If Purchaser agrees with Subcontractor's notice, the parties will negotiate an equitable adjustment to the Subcontract price, to the schedule, or both, in accordance with the Subcontractor's fee for overhead and profit as listed in Article 00572.14.2 below. These adjustments will be reflected in a written Subcontract revision.

00572.14.2 The Subcontractor's fee for overhead and profit shall be determined as follows:

For costs incurred for labor the maximum fee shall be fifteen percent to the Subcontractor or the Sub-subcontractor performing the Work.

For costs incurred for materials and equipment the maximum fee shall be five percent to the Subcontractor or the Sub-subcontractor providing the materials and equipment.

If applicable, the Subcontractor may receive an additional fee of five percent on labor or materials and equipment performed or provided by a Sub-subcontractor, as long as the total combined fee does not exceed fifteen percent.

00572.14.3 A written Subcontract revision is required before Subcontractor is entitled to payment for the Work performed under the Work authorization. Subcontractor will bear the expense of performing any change not supported by a written Work authorization or written Subcontract revision. Purchaser will not be liable to Subcontractor for Claims arising from a decrease in the Work. No change is effective without a written Work authorization or a written Subcontract revision issued by Purchaser.

00572.15 Non-Disclosure

Subcontractor shall not make any news releases, authorize or participate in any interview concerning this Subcontract, or issue other advertising pertaining to the project or this Subcontract without the prior written approval of Purchaser. Subcontractor shall treat all information provided by Purchaser as confidential and only disclose such information as necessary to perform the Work, and will require the employees, agents, and Subcontractors who need to know to adhere to the terms of this provision.

00572.16 Suspension of Work

Purchaser may, at any time and in its sole discretion, suspend performance of all or part of the Work by written notice to Subcontractor. If the suspension is unrelated to Subcontractor's failure to comply with this Subcontract, Purchaser will adjust the schedule to reflect the reasonable delay due to the suspension and will reimburse Subcontractor for the reasonable and direct additional costs incurred by Subcontractor due solely to the suspension. Subcontractor shall promptly resume performance of all or part of the suspended Work in accordance with Purchaser's written authorization to resume the Work.

00572.17 Termination for Cause

If Subcontractor defaults in any obligation under this Subcontract and does not cure the default within ten calendar days after receipt of Purchaser's written notice identifying the default, Purchaser may terminate all or part of the Work.

00572.18 Termination Without Cause

Purchaser may, at any time and in its sole discretion, terminate all or part of the Work. Subject to Subcontractor's compliance with this Subcontract, Subcontractor will recover from Purchaser, as the complete and final settlement for the terminated Work and all related Claims, a sum equal to Subcontractor's direct cost for the terminated Work satisfactorily performed as of the effective date of termination, plus an allowance for reasonable overhead and profit on such direct cost.

00572.19 Purchaser's Remedies

If Subcontractor by its action or inaction indicates that it is unable or unwilling to proceed with the Work in accordance with the schedule or if Purchaser intends to perform any corrective work under Article 00572.10, Purchaser may, upon written notice to Subcontractor, accomplish the Work in question by the most expeditious means available and back-charge Subcontractor for the costs incurred. Subcontractor

shall pay all direct costs incurred by Purchaser under this Article 00572.19, including engineering (charged at \$100/hour), labor, material, transportation, insurance, subcontracts, tools, and equipment. Subcontractor shall also pay twenty-five percent of the direct costs incurred by Purchaser under this Article 00572.19 for Purchaser's overhead and general and administrative costs.

00572.20 Indemnity

00572.20.1 SUBCONTRACTOR AGREES TO DEFEND, INDEMNIFY, AND HOLD HARMLESS THE INDEMNIFIED PARTIES AGAINST ANY CLAIM, LOSS, DAMAGE, EXPENSE, OR LIABILITY (INCLUDING ATTORNEYS' FEES AND COSTS OF ANY SUCCESSFUL ENFORCEMENT OF THIS INDEMNITY ARTICLE) ARISING OUT OF THE PERFORMANCE OR NON-PERFORMANCE BY SUBCONTRACTOR OR ITS SUB-SUBCONTRACTORS, OR THEIR OFFICERS, EMPLOYEES, OR AGENTS.

00572.20.2 Providing that Purchaser is not in breach of its obligation to make payments to Subcontractor for the Work, Subcontractor shall indemnify, defend and hold harmless the Indemnified Parties from any claims or mechanic's liens brought against the Indemnified Parties or against the Project as a result of the failure of Subcontractor, or those for whose acts it is responsible, to pay for any services, materials, labor, equipment, taxes or other items or obligations furnished or incurred for or in connection with the Work. Within three (3) days of receiving written notice from Purchaser that such a claim or mechanic's lien has been filed, Subcontractor shall commence to take the steps necessary to discharge said claim or lien, including, if necessary, the furnishing of a mechanic's lien bond. If Subcontractor fails to do so, Purchaser will have the right to discharge the claim or lien and hold Subcontractor liable for costs and expenses incurred, including attorneys' fees.

00572.20.3 Subcontractor will immediately notify Purchaser of any claim or suit made or filed against Subcontractor or its Sub-subcontractors in which Purchaser or Owner is named as a co-defendant.

00572.21 Insurance Requirements

00572.21.1 Subcontractor shall, at its sole cost, maintain insurance as required by this Subcontract and shall impose the obligations of this Article 00572.21.1 on all Sub-subcontractors. Subcontractor shall give Purchaser ACORD insurance certificates evidencing the required coverage by the due date identified in article titled "Schedule of Submittals" and as Purchaser may request from time to time. Subcontractor shall ensure the policies:

- (a) Contain a provision or endorsement that the coverage will not be cancelled materially changed, or renewal refused unless the insurer gives at least thirty calendar days prior written notice to Purchaser.
- (b) Remain in effect through the warranty period if coverage is occurrence-based and remain in effect at least one year after expiration of the warranty period if coverage is claims-based.
- (c) Are primary with respect to insurance covering Indemnified Parties as additional insureds. All insurance carried by Indemnified Parties will be excess insurance.
- (d) Contain a waiver of all rights of subrogation by the insurance carriers in favor of Indemnified Parties.
- (e) Comply with all Applicable Laws of the jurisdiction in which any part of the Work is to be performed including, but not limited to, admitted and compulsory coverage.
- (f) Are rated "A-" or better by A.M. Best's "Insurance Guide and Ratings."

00572.21.2 Subcontractor shall maintain broad form commercial general liability insurance protecting Subcontractor, and Indemnified Parties as additional insureds (using endorsements CG 20 10 and CG 20 37 or their equivalent), against claims arising out of bodily injury or property damage arising from the Work. The policy must include a cross-liability or severability of interest clause, a per project aggregate endorsement, and coverage for personal injury liability, contractual liability, products and completed operations (covering lawsuits brought in the USA and the country of the jobsite), explosion, building collapse, and damage to underground property. The policy must include coverage for riggers liability if applicable to the Work. Subcontractor shall maintain policy limits of at least one million dollars for each occurrence.

00572.21.3 Subcontractor shall maintain worker's compensation insurance protecting Subcontractor against all claims under applicable worker's compensation laws, including, but not limited to, the United States Longshoremen's and Harbor Worker's Act and the Jones Act. If Subcontractor is required to maintain worker's compensation insurance in the USA, the worker's compensation insurance must contain an "all states" or "other states" endorsement. For Work performed in the USA, Subcontractor shall also maintain employer's liability insurance protecting Subcontractor against claims for injury, disease or death of employees which are not covered by the worker's compensation insurance. Subcontractor shall maintain worker's compensation policy limits as required by statute and, if applicable to this Subcontract, employer's liability policy limits of at least one million dollars for each occurrence.

00572.21.4 Subcontractor shall maintain comprehensive automobile liability insurance protecting Subcontractor, and Indemnified Parties as additional insureds, against all claims for injuries to members of the public and damage to property of others arising from the use of motor vehicles, whether owned, non-owned, or hired. Subcontractor shall maintain policy limits of at least one million dollars for each occurrence.

00572.21.5 Subcontractor shall maintain umbrella liability insurance that follows the form of the commercial general liability insurance, the employer's liability insurance and the automobile liability insurance. The umbrella liability insurance must protect Subcontractor, and Indemnified Parties as additional insureds, against claims in excess of the limits of the commercial general liability insurance, the employer's liability insurance, and the automobile liability insurance. Subcontractor shall maintain policy limits of at least four million dollars for each occurrence.

00572.21.6 Subcontractor is responsible for maintaining any and all property insurance on their own equipment and shall require all Sub-subcontractors to do likewise.

00572.22 Audit

Purchaser reserves the right to audit the records of Subcontractor. Accordingly, Subcontractor shall make and keep as the same accrue, full and complete records and books of accounts of revenue and income, and costs and expenses that specifically relate to performance under this Subcontract. Records and books of account, together with any or all memoranda pertaining thereto that may be kept, maintained, or possessed by Subcontractor, shall be opened to examination during regular business hours by Purchaser or its representatives for the purposes of inspecting, auditing, verifying, or copying the same or making extracts therefrom. Subcontractor shall make and keep said records and books of account for a period of seven (7) years after the completion of the contract obligations of the final payment under the Subcontract, whichever is later.

00572.23 Governing Law and Disputes

Claims and disputes arising out of or relating to this Subcontract will be governed by the law of the State of Missouri, USA, excluding provisions that would apply the law of another jurisdiction. Pending resolution of any claim or dispute, and without prejudice to Subcontractor's rights, Subcontractor shall continue to perform as directed by Purchaser.

00572.24 Hazardous Conditions

00572.24.1 Subcontractor is not responsible for any Hazardous Conditions encountered in the performance of the Work at the Jobsite. Upon encountering any Hazardous Conditions, Subcontractor will stop services immediately in the affected area and duly notify Purchaser. For purposes of this Subcontract, Hazardous Conditions is defined as any materials, wastes, substances and chemicals deemed to be hazardous under any Applicable Law or the handling, storage, remediation, or disposal of which are regulated by Applicable Laws and applies to any hazardous or toxic substance, material, or condition present at the locations in which the Work is performed which was not brought onto such site or sites by Service Contractor for the exclusive benefit of Subcontractor.

00572.24.2 Subcontractor shall be obligated to resume the Work at the affected areas only after Owner's expert provides it with written certification that (i) the Hazardous Conditions have been removed or rendered harmless and (ii) all necessary approvals have been obtained from all Governmental Authority having jurisdiction over the location.

00572.24.3 Subcontractor will be entitled, to an adjustment in its compensation and all times for performance of the Work to the extent Subcontractor cost or time of performance have been adversely impacted by the presence of Hazardous Conditions, subject to submission of appropriate documentation by Subcontractor and Subcontractor's duty to mitigate.

00572.25 Force Majeure

00572.25.1 If Subcontractor is delayed in the performance of the Work due to acts, omissions, conditions, events, or circumstances beyond its control, the times for performance shall be reasonably extended by on a not less than day for day basis. By way of example and not of limitation, events that will entitle Subcontractor to an extension of the times for performance include without limitation acts or omissions of Owner or Purchaser, or anyone under Owner's control (including separate contractors), Hazardous Conditions, wars, terrorism, civil unrest, actions and inactions of delay of Governmental Authorities, floods, labor disputes and unrest, unusual delay in transportation, epidemics, earthquakes, tsunami, adverse weather conditions, and acts of God.

00572.25.2 In addition to Subcontractor's right to a time extension for those events set forth above, Subcontractor shall also be entitled to an appropriate increase in the compensation due to the impacts or delays arising from such events. Subcontractor will file all claims in accordance with Article 00572.13.

00574 – Jobsite Operations Terms and Conditions

00574.1 Subcontractor Scope of Work

Except as expressly provided in this Subcontract, Subcontractor shall furnish all materials, tools, equipment, vehicles, supplies, services, labor and supervision required to perform the Work. Unless otherwise stated in this Subcontract, the Work includes unloading, off transport, hauling, receiving, storing, maintaining, protecting, erecting, installing, cleaning, adjusting, and all other work required to make the Work ready for use.

00574.2 Safety Requirements

00574.2.1 Subcontractor shall conduct all operations under this Subcontract in a manner that avoids the risk of bodily harm and damage to property. At a minimum, Subcontractor shall comply with the requirements of this Article 00574.2, Section 00575, the Loss Control Manual, and Owner's safety requirements. Subcontractor's failure to comply with the requirements of this Article 00574.2, Section 00575, the Loss Control Manual, or Owner's safety requirements constitutes a material breach of this Subcontract.

00574.2.2 When at the jobsite, Subcontractor shall continuously inspect all Work and conduct surveys of all Work areas to identify any unsafe condition and shall immediately take adequate precautions against any unsafe condition identified. Subcontractor is solely and exclusively responsible for the discovery and correction of such conditions. Subcontractor agrees that nothing contained in this Article 00574.2, Section 00575, the Loss Control Manual, or Owner's safety requirements shifts responsibility for bodily harm or damage to property sustained resulting from violation of those provisions from Subcontractor to Owner or Purchaser. Subcontractor remains solely and exclusively responsible for compliance with all safety requirements.

00574.2.3 Subcontractor shall immediately correct any unsafe condition identified by Purchaser. If, in Purchaser's sole discretion, Subcontractor has not taken sufficient precautions for the avoidance of bodily harm and damage to property, or in response to Purchaser's identification of an unsafe condition, Purchaser may stop the Work at Subcontractor's expense or implement suitable precautions at Subcontractor's expense, or both. Purchaser's right to stop the Work and to implement suitable precautions does not impose on Purchaser a duty to exercise those rights and does not relieve Subcontractor of responsibility for damage resulting from violation of this Article 00574.2, Section 00575, the Loss Control Manual, or Owner's safety requirements.

00574.2.4 Compliance with this Article 00574.2, Section 00575, the Loss Control Manual, and Owner's safety requirements is the minimum standard required of Subcontractor. Subcontractor is responsible for examining all Work-related requirements and determining whether additional or more stringent health and safety provisions are required or appropriate for the Work. Subcontractor shall notify Purchaser promptly in writing if a charge of noncompliance with this Article 00574.2, Section 00575, the Loss Control Manual or Owner's safety requirements has been filed against Subcontractor or a Sub-subcontractor in connection with the performance of the Work.

00574.3 Labor

Subcontractor shall designate a supervisor at the jobsite who has the authority to act on behalf of and to bind Subcontractor in all matters relating to or arising out of this Subcontract. The supervisor must be fluent in English. Subcontractor agrees to replace, at no cost to Purchaser, any Sub-subcontractor or any personnel of Subcontractor or Sub-subcontractor who Purchaser reasonably requests be replaced.

00574.4 Work Hours

Typical Work days consist of a Monday through Friday schedule with a 7am start at the earliest, and a 6pm finish at the latest. Saturday Work may be permitted as necessary. Sunday Work will not be permitted, unless deemed by the Program Manager to be of a critical or emergency nature. No Work is

permitted on Memorial Day, Independence Day, Labor Day, Thanksgiving Thursday and Friday, Christmas Eve, Christmas and New Year's Day, during the Subcontract duration.

For weekend operations, requests must be submitted in writing by Thursdays at NOON.

In cases where the Program Manager does not have the resources available to observe Saturday, Sunday, and/or night work, the request will be denied and no time extension or impact will be considered.

Night Work, when deemed necessary by the Program Manager; will be permitted as requested (48-hour advance notice required). Noise attenuated equipment for night work is required when working in residential neighborhoods.

00574.5 Protection and Restoration of Property

00574.5.1 Subcontractor shall, at its expense, protect the Work, the environment, and all other property from hazards arising out of or relating to the Work and from natural elements. Subcontractor shall, at its expense, promptly repair or remove and replace any damage or loss and, to the extent practicable, restore property affected by the Work to its original condition, as determined by Purchaser. Subcontractor is solely responsible for protection of the Work until Final Completion.

00574.5.2 At the completion of the Work, Subcontractor shall remove all Subcontractor-furnished items that are not intended to become a permanent part of the project from the jobsite and shall remove and deposit in Subcontractor-furnished waste facilities all scrap, trash, waste materials, and debris resulting from the Work. Subcontractor shall thoroughly remove all accumulations of dust, scraps, waste, oil, grease, weld spatter, insulation, paint, and other foreign substances resulting from performance of the Work and shall restore all surfaces affected by those substances.

00575 - Safety, Health and Accident Prevention

00575.1 Project Safety and Health Program

Purchaser will implement and coordinate the overall Project Safety and Health Program as defined in the Loss Control Manual which is available for inspection at the SARP10 Program Office.

00575.2 Safety, Health, and Accident Prevention Program

00575.2.1 Subcontractor shall implement and maintain a written Safety, Health and Accident Prevention Program specifically applicable to the Work. Subcontractor's Safety, Health and Accident Prevention Program must meet the requirements of Applicable Laws and adhere to the Project Safety and Health Program, if implemented by Purchaser. Subcontractor shall submit Subcontractor's Safety, Health and Accident Prevention Program for Purchaser's review at least thirty calendar days before starting Work at the jobsite. Purchaser's review does not relieve Subcontractor of Subcontractor's sole responsibility for safety and health in relation to the Work, nor does Purchaser's review limit Subcontractor's obligation to undertake any action necessary to establish and maintain safe working conditions relating to the Work at the jobsite.

00575.2.2 Purchaser may monitor Subcontractor's safety and health performance and may require changes to Subcontractor's Safety, Health and Accident Prevention Program during the performance of the Work. Purchaser's monitoring and requirement of changes does not relieve Subcontractor of Subcontractor's sole responsibility for safety and health in relation to the Work, nor does Purchaser's monitoring and requirement of changes limit Subcontractor's obligation to undertake any action necessary to establish and maintain safe working conditions relating to the Work at the jobsite.

00575.3 Hazardous Waste Project Health and Safety Plan

00575.3.1 Subcontractor understands that the Work involves hazardous substances or hazardous wastes. Subcontractor shall comply with all Applicable Laws, Owner's facility rules and regulations, and applicable guidance documents. Subcontractor shall prepare and implement a jobsite-specific Hazardous Waste Project Health and Safety Plan, based on Subcontractor's Safety, Health and Accident Prevention Program and all written programs required by Applicable Laws. Subcontractor is responsible for the completeness and accuracy of Subcontractor's Hazardous Waste Project Health and Safety Plan. Subcontractor shall submit Subcontractor's Hazardous Waste Project Health and Safety Plan to Purchaser at least thirty calendar days before starting Work at the jobsite and shall maintain a copy at the jobsite for review by Purchaser, Owner, and regulatory personnel.

00575.3.2 Before starting Work at the jobsite, Subcontractor shall submit written verification that:

- (a) personnel assigned to the Work have received forty hour health and safety training that meets the requirements of 29 CFR 1910.120(e) or 1926.65(e);
- (b) the assigned field supervisor has completed eight hours of supervisor training that meets the requirements of 29 CFR 1910.120(e)(4) or 1926.65(e)(4); and
- (c) personnel assigned to the Work are participating in a medical surveillance program that meets the requirements of 29 CFR 1910.120(f) or 1926.65(f).

00575.4 Protective Clothing, Equipment and Instrumentation

Subcontractor agrees to furnish special protective clothing, respiratory protective equipment, and monitoring instrumentation as required by Applicable Laws, the project's safety-related plans and programs, and Purchaser's and Owner's rules and regulations. Subcontractor shall ensure that personnel performing Work at the jobsite properly use the clothing, equipment, and instrumentation. Subcontractor shall furnish and maintain all safety equipment, including but not limited to, barriers, signs, warning lights, and guards necessary for adequate protection of persons and property.



00575.5 Safety and Health Representative

The Subcontractor shall identify a qualified person to be its representative for Environmental, Safety, Health & Security matter and make this person available as needed and requested by the Purchaser. The representative must have authority to correct unsafe conditions and to stop Work in the area of an unsafe condition. In addition, the representative shall routinely visit the jobsite.

00575.6 Safety and Health Goal

Subcontractor shall endeavor to attain the project's safety goal of zero injuries. Subcontractor shall maintain accurate accident and injury reports and shall furnish Purchaser a monthly summary of injuries and man-hours lost due to injuries by the third of each month. Subcontractor accident rates must be calculated monthly in accordance with the Bureau of Labor Statistics incident rate, frequency rate, and days away from work rate methods. If Subcontractor or Sub-subcontractor accident rates exceed the project's safety goal, Subcontractor shall take immediate corrective action, which may include, but is not limited to:

- (a) submittal of a written corrective action plan to Purchaser by Subcontractor;
- (b) additions or modifications to Subcontractor's Safety, Health and Accident Prevention Program;
- (c) removal from the jobsite of any Subcontractor or Sub-subcontractor personnel not implementing or following the necessary safety and health measures; and
- (d) increasing the amount of Subcontractor safety and health training.

00575.7 Drug Prevention Program

As part of the Work, Subcontractor shall assist Purchaser in administering the project requirements for a drug detection and prevention program. Subcontractor agrees that all costs for drug testing and alcohol testing are included in the Subcontract price. Subcontractor must provide evidence to Purchaser that all personnel assigned to the Work at the jobsite have passed the drug test within three calendar days of completion of the test. The drug detection and prevention program will include, but will not be limited to, the following: (a) a pre-jobsite assignment test; and (b) post-jobsite assignment tests, such as reasonable suspicion tests, post-accident tests, and unannounced random drug tests of ten percent of the workforce on a monthly basis.

00575.8 Fall Protection

The OSHA Fall Protection Standard 29 CFR 1926 Subpart M shall be strictly adhered to by the Subcontractor. Fall protection is required for all of Subcontractor's Work operations one hundred percent of the time, whether climbing, traveling, or working. NO WORK OPERATION is exempt from the six (6) foot fall protection requirement.

Prior to starting work operations requiring fall protection, Subcontractor shall submit to Purchaser a fall protection plan. The fall protection plan shall include, but not be limited to, the following:

Name of qualified person in charge of operation.

Description of work operation.

List of fall exposures.

Description of fall protection methods used to eliminate fall exposures.

Training and enforcement methods used to ensure employee compliance with the plan.

Fall protection body harnesses, lanyards, and lifelines shall be used in accordance with OSHA Standard



1926 Subpart 502D, with the following exceptions:

Full body harnesses shall be used in lieu of safety belts.

Only lanyards with shock absorbers and locking type snap hooks shall be used.

At least two lanyards shall be used to provide one hundred percent fall protection when moving around obstructions, connection points, or other similar items.

Fall protection guardrail systems shall comply with OSHA Standard 1926 Subpart 502(b) except manila, plastic, or synthetic rope shall not be used as guardrails.

00575.9 Sub-subcontractor Safety Prequalification

Prior to any Sub-subcontractor performing Work on the Jobsite the Sub-subcontractor must obtain a Sub-subcontractor safety prequalification from Purchaser. In order to obtain the safety prequalification, Subcontractor or its Sub-subcontractor shall submit to Purchaser evidence that the Sub-subcontract has an Experience Modification Rating or equivalent rating of 1.0 or less and that incident rates (Recordable Incident Rate, Loss Time Incident Rate, and Days Away/Restricted or Job Transfer rate) are below the national average during the last three years. In addition, Subcontractor or Sub-subcontractor must submit sufficient information to allow Purchaser to evaluate any Occupational Safety and Health Administration (OSHA) violations received by Sub-subcontractor within the last three years and any other documentation Purchaser may reasonably require. Purchaser's safety manager will review the submission and provide a safety prequalification if Purchaser, in its sole discretion, determines the Sub-subcontractor meets Purchaser's safety requirements. Subcontractor or its Sub-subcontractor must submit the requirements prior to Sub-subcontractor first mobilizing to the Jobsite.

00575.10 Confined Spaces

All employees entering confined spaces and all attendants for such entries including supervisors shall receive confined space entry training and emergency rescue training at a minimum of once per year.

00672 - General Conditions Attachments

00672.1 Partial Waiver and Release of Lien Rights

**AFFIDAVIT AND PARTIAL WAIVER OF CLAIMS AND LIENS
AND RELEASE OF RIGHTS FOR SUBCONTRACTORS**

The undersigned, who is the _____ (designate title) of _____ which is the _____ (designate whether subcontractor, supplier or otherwise) for the _____ (designate the type of work, supplies or services rendered) on the improvements constructed on the premises hereafter identified, declares that his contract with _____ (General Contractor) is in the total amount of \$ _____, which includes extras and all change orders to the date hereof.

The undersigned further states that as of _____ (date) the total value of work completed and material stored is \$ _____. Of this amount \$ _____ has been received (the receipt and sufficiency of which is hereby acknowledged by the undersigned including \$ _____ in payment of Payment Application or Invoice Number _____). A total of \$ _____ is being held as retainage.

In consideration of the amounts and sums received, the undersigned does hereby waive and release to the **City of Memphis (Owner)** and to _____ (General Contractor) any and all claims and liens and rights to liens upon the premises described below and upon improvements now thereon, and upon the monies or other considerations (due as of the date of the aforesaid payment application or invoices from the **City of Memphis (Owner)** or _____ (General Contractor) or from any other person, firm or corporation), said claims and liens and rights to liens being on account of labor, services, materials, fixtures or apparatus heretofore furnished by or at the request of the undersigned. The premises as to which said claims and liens and rights to liens are hereby released are identified as follows:

Project Name: Wolf River Interceptor Rehab

Address of Project:

City: _____ **County:** Shelby **State:** TN **Zip Code:** _____

The undersigned further represents and warrants that he is duly authorized and empowered to sign and execute this waiver on his own behalf and on behalf of the company or business for which he is signing; that he has properly performed all work and furnished all the materials of the specified quality per plans and specifications and in a good and workmanlike manner through the date of said payment application or invoice; that he has paid for all the labor, materials, equipment, and services that he has used or supplied to the above premises through the date of said payment application or invoice; that he has no other outstanding and unpaid payment applications, invoices, retentions, holdbacks, chargebacks or unbilled work or materials against _____ (General Contractor) as of the date of the aforementioned payment application; and that any materials which have been supplied or incorporated into the above premises were either taken from his fully-paid or open stock or were fully paid for and supplied as stated on the payment application or invoice.

The undersigned further agrees to reimburse and does hold harmless and fully indemnify the **City of Memphis (Owner)** and _____ (General Contractor) for any losses or expenses should any such claims, lien or right to a lien be asserted (by the undersigned or by any laborer, materialman or subcontractor of the undersigned), including, without implied limitation, attorneys' fees incurred in the defense thereof.



The undersigned further accepts and acknowledges the receipt of the aforesaid sums in full accord and satisfaction for the aforementioned claims with full knowledge that the contractors, **City of Memphis (Owner)** and _____ (General Contractor), their successors and assigns, are relying thereon; and furthermore, the undersigned agrees to perform, now and in the future, each and every covenant and provision of this written contract or supplier's agreement (as the case may be) as modified or changed in writing with _____ (General Contractor) or any subcontractor of _____ (General Contractor) hereby acknowledging that said contract or supplier's agreement is now in full force and effect.

In addition, for and in consideration of the amounts and sums received, the undersigned hereby waives, releases and relinquishes any and all claims, rights or causes of action whatsoever arising out of or in the course of the work performed on the above-mentioned project, contract or event transpiring prior to the date hereof, excepting the right to receive payment for work performed and properly completed and retainage, if any, after the date of the above-mentioned payment application or invoices.

Signed and delivered the _____ day of _____, 20_____.

Company _____

By: _____
(Printed Name)

(Signature)

Title: _____

Before me, the undersigned Notary Public in and for the said County and State, personally appeared _____, and acknowledged execution of the foregoing affidavit as his voluntary act and deed and further stated that the facts recited are true of his personal knowledge.

My Commission Expires: _____

Notary Public

Residence County/State: _____

00672.2 Final Waiver and Release of Lien Rights

**AFFIDAVIT AND FINAL WAIVER OF CLAIMS AND LIENS
AND RELEASE OF RIGHTS FOR SUBCONTRACTORS**

The undersigned, who is the _____ (designate title) of _____ which is the _____ (designate whether subcontractor, supplier or otherwise) for the _____ (designate the type of work, supplies or services rendered) on the improvements constructed on the premises hereafter identified, declares that his contract with _____ (General Contractor) is in the total amount of \$ _____, which includes extras and all change orders to the date hereof.

The undersigned further states that as of _____ (date) all work on said project has been performed and completed in accordance with the plans and specifications for the project, and said work has been accomplished in accordance with the terms and conditions of his subcontract and those documents which, by reference, are a part of said subcontract. The total value of work completed and material stored is \$ _____. Of this amount \$ _____ has been received (the receipt and sufficiency of which is hereby acknowledged by the undersigned including \$ _____ in payment of Payment Application or Invoice Number _____. A total of \$ _____ is being held as retainage.

In consideration of the amounts and sums received, the undersigned does hereby waive and release to the **City of Memphis (Owner)** and to _____ (General Contractor) any and all claims and liens and rights to liens upon the premises described below and upon improvements now thereon, and upon the monies or other considerations (due as of the date of the aforesaid payment application or invoices from the **City of Memphis (Owner)** or _____ (General Contractor) or from any other person, firm or corporation), said claims and liens and rights to liens being on account of labor, services, materials, fixtures or apparatus heretofore furnished by or at the request of the undersigned. The premises as to which said claims and liens and rights to liens are hereby released are identified as follows:

Project Name: Wolf River Interceptor Rehab

Address of Project:

City: _____ **County:** Shelby **State:** TN **Zip Code:** _____

The undersigned further represents and warrants that he is duly authorized and empowered to sign and execute this waiver on his own behalf and on behalf of the company or business for which he is signing; that he has properly performed all work and furnished all the materials of the specified quality per plans and specifications and in a good and workmanlike manner as required by the contract; that he has paid for all the labor, materials, equipment, and services that he has used or supplied to the above premises as required by the contract; that he has no other outstanding and unpaid payment applications, invoices, retentions, holdbacks, chargebacks or unbilled work or materials against _____ (General Contractor); and that any materials which have been supplied or incorporated into the above premises were either taken from his fully-paid or open stock or were fully paid for and supplied as stated on the payment application or invoice.

The undersigned further agrees to reimburse and does hold harmless and fully indemnify the **City of Memphis (Owner)** and _____ (General Contractor) for any losses or expenses should any such claims, lien or right to a lien be asserted (by the undersigned or by any laborer, materialman or subcontractor of the undersigned), including, without implied limitation, attorneys' fees incurred in the defense thereof.



The undersigned further accepts and acknowledges the receipt of the aforesaid sums in full accord and satisfaction for the aforementioned claims with full knowledge that the contractors, **City of Memphis (Owner)** and _____ (General Contractor), their successors and assigns, are relying thereon; and furthermore, the undersigned agrees to perform, now and in the future, each and every covenant and provision of this written contract or supplier's agreement (as the case may be) as modified or changed in writing with _____ (General Contractor) or any subcontractor of _____ (General Contractor) hereby acknowledging that said contract or supplier's agreement is now in full force and effect.

In addition, for and in consideration of the amounts and sums received, the undersigned hereby waives, releases and relinquishes any and all claims, rights or causes of action whatsoever arising out of or in the course of the work performed on the above-mentioned project, contract or event transpiring prior to the date hereof, except retainage, if any, after the date of the above-mentioned payment application or invoices.

Signed and delivered the _____ day of _____, 20____.

Company _____

By: _____
(Printed Name)

(Signature)

Title: _____

Before me, the undersigned Notary Public in and for the said County and State, personally appeared _____, and acknowledged execution of the foregoing affidavit as his voluntary act and deed and further stated that the facts recited are true of his personal knowledge.

My Commission Expires: _____

Notary Public

Residence County/State: _____

00672.3 Certificate of Nondiscrimination (1 page)



As Bidder, Contractor, or Subcontractor on Purchaser's Contract, Wolf River Interceptor Rehab

The undersigned states that it does not discriminate against any subcontractor, employee, or applicant for employment on the grounds of race, color, national origin or sex and, if awarded a contract for this project, agrees in performance of work:

1. Not to discriminate against any subcontractor, employee, or applicant for employment on the grounds of race, color, national original or sex;
2. To maintain payrolls of laborers and mechanics employed on this contract until seven (7) years after final release and final payment by the City;
3. To require a similar certificate to be executed by each subcontractor at the time a subcontract is executed under the contract with the requirement that such subcontractor agrees to require a similar certificate of requirement on any lower tiers of subcontracts.
4. To conform to federal law, state statutes, executive orders, and local ordinances identified and listed under Non-discrimination.

Service Contractor's Name

Date

Signature

Printed or Typed Name and Title

**THIS FORM MUST BE SUBMITTED WITH THE PROPOSAL OR
THE PROPOSAL MAY BE CONSIDERED NON-CONFORMING.**

00672.4 Equal Business Opportunity Program

This form must be submitted with Bidder's bid. Failure to execute and submit this document with Bidder's bid may cause the Bid to be rejected as non-conforming. In addition, each Sub-Subcontractor must execute the form.

This Subcontract will be subject to the requirements of the City of Memphis Ordinance #5384 which establishes the Equal Business Opportunity ("EBO") Program. It is up to the Respondent to ensure that all requirements of this ordinance are met. The Ordinance may be accessed on the City's website at www.memphistn.gov under "Office of Contract Compliance". The intent of the EBO Program is to increase the participation of locally owned minority and women owned business enterprises ("M/WBE"). Toward achieving this objective, the overall M/WBE participation goal for this solicitation is 15%. The percentage of overall M/WBE participation is defined as the dollar value of subcontracts awarded to certified (as identified by the City of Memphis EBO list) minority and/or women business enterprises divided by the total proposed base bid amount.

Additionally, in accordance with federal executive Order 11625 and 12138, the local government must make a good faith effort to include participation from Disadvantage Business enterprises (DBE) in sub-agreement awards. The SRF Fair Share DBE goal for this project is a minimum of **2.6%** WBE and minimum of **2.6%** MBE (as identified by the Tennessee Uniform Certification Program list, other State or Federal DBE lists, or the City of Memphis EBO list).

SRF Fair Share Goals:

MBE goal – Construction **2.6%**

WBE goal – Construction **2.6%**

(Vendors from the TDOT TNUCP DBE list, other State or Federal DBE lists, or the City of Memphis EBO list)

SARP10 DBE Participation goal: **15%**

(Vendors from the City of Memphis EBO list only)

Participation Plan

The Participation Plan must include: (1) level and dollar amount of participation your firm anticipates to achieve in the performance of contract resulting from this RFB; (2) the type of work to be performed by the M/WBE participation; and (3) the names of the M/WBE and/or DBE firm(s) the Respondent plans to utilize in the performance of the contract resulting from this RFB.

Eligible M/WBE and/or DBE Firms

To qualify as a M/WBE firm, per the requirements of City of Memphis Ordinance #5384, a firm must be included on the City's EBO list of certified M/WBE firms. All contractors identified as an SRF Fair Share M/WBE firm must be on the Tennessee Uniform Certification Program (TNUCP) list, other State or Federal DBE lists, or the City of Memphis EBO list at the time of the bid opening.

A list of the City's eligible M/WBE firms may be requested from Purchaser as a guide only. If a Bidder desires to utilize an M/WBE firm not included on the list, it is the Bidder's responsibility to confirm that the desired firm is certified by the City of Memphis. Such confirmation must be obtained from the City's Contract Compliance Office, in writing, before the bid/response due date. Requests for verification must be submitted to the City's Contract Compliance Office listed below:

Joann Massey
City of Memphis, Contract Compliance Office
125 North Main Street, Suite 546
Memphis, TN 38103
Phone: (901) 576-6210 - Fax: (901) 576-6560
Email: joann.massey@memphistn.gov



MINORITY/WOMEN BUSINESS ENTERPRISE COMPLIANCE FORM

SUBCONTRACT TITLE: Wolf River Interceptor Rehab

Project M/WBE Goal: MBE minimum **2.6%**
 WBE minimum **2.6%**
 DBE minimum **15%**

The following sections must be completed by Bidder. A certified subcontractor or supplier is defined as a firm from the list of certified firms provided with this specification.

 Bidder's Name

Section A - If the Bidder is a certified firm, so indicate here with a check mark.

_____ MBE _____ WBE _____ DBE

Section B - Identify below those certified firms that will be employed as subcontractors or suppliers on this Project. By submitting this Proposal, the Bidder commits to the use of the firms listed below.

- \$ = Show the dollar value of the subcontract to be awarded to this firm
- % = Show the percentage this subcontract is of your base Proposal
- M/WBE = Show by inserting an M or W whether the subcontractor is an MBE or WBE

\$	%	M/WBE	DBE	CERTIFIED SUBCONTRACTOR NAME, ADDRESS, TEL #
_____	_____	_____	_____	_____
_____	_____	_____	_____	_____
_____	_____	_____	_____	_____
_____	_____	_____	_____	_____
_____	_____	_____	_____	_____
_____	_____	_____	_____	_____
_____	_____	_____	_____	_____
_____	_____	_____	_____	_____

\$ _____ % _____ = **Total M/WBE and/or DBE**

THIS FORM MUST BE SUBMITTED WITH THE PROPOSAL OR THE PROPOSAL MAY BE CONSIDERED NON-CONFORMING

00672.5 Report of Disadvantaged Business Enterprise Participation Form (1 page)



00672.6 State Revolving Fund (SRF) Front-Ends (48 pages)

This Project 194677.71.0397 must maintain SRF compliance for the SARP10 Program, the SRF "Front-Ends" consisting of various forms and documents are attached herein. Furthermore, Davis Bacon is referenced within these SRF Front-Ends, and applies to the Scope of Work. As a special note, the Bidder's Requirements on page 15 of 48 of the SRF Front-Ends, outlines Pre-Bid Requirements where all bidders must send certified mail and return receipts to a minimum of 10 certified DBE subcontractors, soliciting their service.

The following SRF Forms are to be submitted with your Bid and will be attached to the Subcontract:
(Please also include a signed form from each Sub-subcontractor as applicable. Refer to Table 00370.8 Schedule of Submittals)

1. Certification Regarding Debarment (page 2 of 48)
2. Certification Regarding Equal Employment Opportunity (page 3 of 48)

STATE REVOLVING FUND LOAN PROGRAM

Inserts for Specifications

Clean Water – Unsubsidized

Projects Funded with FY 2010 and After Funds

Subject	File Name
Certification Regarding Debarment	02_CertificationRegardingDebarment.pdf
Certification Regarding Equal Employment Opportunity	03_CertificationRegardingEqualEmploymentOps.pdf
Retainage – TCAs 66-34-104, 203,103	04_RetainageTCAs.pdf
Advertisement for Bids Example – DBE	05_AdvertisementForBidsExample_DBE.pdf
DBE-Guidance Document	06_DBE01_GuidanceDocument.pdf
DBE-Loan Recipient's Requirements	06_DBE02_LoanRecip_Requirements.pdf
DBE-Loan Recipient's Good Faith Effort Letter	06_DBE03_LoanRecip_GoodFaithEffortLtr.pdf
DBE-Loan Recipient's Certification Summary Form	06_DBE04_LoanRecip_CertificationSummaryForm.pdf
DBE-Bidder's Requirements	06_DBE05_BidderRequirements.pdf
DBE-Certified List	06_DBE10_CertifiedList.pdf
Davis Bacon Poster - English	08_DavisBacon_Poster_English.pdf
Davis Bacon Poster - Spanish	08_DavisBaconsigninSpanish.pdf
Project Wage Sheet - HUD-4720	08_ProjectWageSheet_HUD-4720.pdf
Wage Rate - Bidder's Guidance to Davis Bacon	08_WageRates_BidderGuidanceToDavisBacon_20110215.pdf
Wage Rate – Loan Recipient's Guidance to DavisBacon	08_WageRates_LoanRecipGuidanceToDavisBacon_20110215.pdf
Tracking and Reporting – Loan Recipient's and Contractor's Guidance	09_TrackingAndReporting_LoanRecipAndBidderGuidance_FY2010andAfter.pdf
Storm Water General Permit NOI	11_StormWater_NOI.pdf
Storm Water General Permit NOT	11_StormWater_NOT.pdf
Project Sign Detail - Clean Water – Unsubsidized	14_CWSRF_ProjectSign_Color_Unsubsidized.pdf
Project Sign Detail - Clean Water – Unsubsidized	14_CWSRF_ProjectSign_NoColor_Unsubsidized.pdf
Project Sign Detail - Clean Water – Unsubsidized	15_BidPackageSubmittalRequirements.pdf
Bid Package Submittal Requirements	16_LetterInLieuofaSiteCertificate.pdf
Letter In Lieu of a Site Certificate	16_SiteCertificate.pdf
Site Certificate	

U.S. Environmental Protection Agency

CERTIFICATION REGARDING DEBARMENT, SUSPENSION AND OTHER RESPONSIBILITY MATTERS

The prospective participant certifies to the best of its knowledge and belief that it and its principals:

- (a) Are not presently debarred, suspended, proposed for debarment, declared ineligible, or voluntarily excluded from covered transactions by any Federal department or agency;
- (b) Have not within a three year period preceding this proposal been convicted of or had a civil judgement rendered against them for commission of fraud or a criminal offense in connection with obtaining, attempting to obtain, or performing a public (Federal, State, or local) transaction or contract under a public transaction; violation of Federal or State antitrust statues or commission of embezzlement, theft, forgery, bribery, falsification or destruction of records, making false statements, or receiving stolen property;
- (c) Are not presently indicted for or otherwise criminally or civilly charged by a government entity (Federal, State, or local) with commission of any of the offenses enumerated in paragraph (b) of this certification; and
- (d) Have not within a three-year period preceding this application/proposal had one or more public transactions (Federal, State, or local) terminated for cause or default.

I understand that a false statement on this certification may be grounds for rejection of this proposal or termination of the award. In addition, under 18 USC Sec. 1001, a false statement may result in a fine of up to \$10,000 or imprisonment for up to 5 years, or both.

Typed Name & Title of Authorized Representative

Signature of Authorized Representative

Date

I am unable to certify to the above statements. My explanation is attached.

**CERTIFICATION BY PROPOSED PRIME OR SUBCONTRACTOR REGARDING
EQUAL EMPLOYMENT OPPORTUNITY**

Name of Prime Contractor

Project Number

INSTRUCTIONS

This certification is required pursuant to Executive Order 11246, Part II, Section 203 (b), 30 F.R. 12319-25). Any bidder or prospective contractor, or any of their proposed subcontractors, shall state as an initial part of the bid or negotiations of the contract whether it has participated in any previous contract or subcontract subject to the equal opportunity clause; and, if so, whether it has filed all compliance reports due under applicable instructions.

Where the certification indicated that the prime or subcontractor has not filed a compliance report due under applicable instruction, such contractor shall be required to submit a compliance report.

CONTRACTOR'S CERTIFICATION

Contractor's Name: _____

Address: _____

1. Bidder has participated in a previous contract or subcontract subject to the Equal Opportunity Clause. Yes No
2. Compliance Reports were required to be filed in connection with such contract or subcontract. Yes No

If yes, state what reports were filed and with what agency.

3. Bidder has filed all compliance reports due under applicable instructions, including SF-100. Yes No
4. If answer to Item 3 is NO, please explain in detail on reverse side of this certification.

Certification - The information above is true and complete to the best of my knowledge and belief. (A willfully false statement is punishable by law-U.S. Code, Title 18, Section 1001.)

Name and title of signer (Please type)

Signature

Date

*** Current through the 2015 Regular Session ***

Title 66 Property
Chapter 34 Prompt Pay Act
Part 1 General Provisions

Tenn. Code Ann. § 66-34-103 (2016)

66-34-103. Withholding of retainage -- Violations -- Penalties.

(a) All construction contracts on any project in this state, both public and private, may provide for the withholding of retainage; provided, however, that the retainage amount may not exceed five percent (5%) of the amount of the contract.

(b) The owner, whether public or private, shall release and pay all retainages for work completed pursuant to the terms of any contract to the prime contractor within ninety (90) days after completion of the work or within ninety (90) days after substantial completion of the project for work completed, whichever occurs first. As used in this subsection (b), work completed shall be construed to mean the completion of the scope of the work and all terms and conditions covered by the contract under which the retainage is being held. The prime contractor shall pay all retainages due any subcontractor within ten (10) days after receipt of the retainages from the owner. Any subcontractor receiving the retainage from the prime contractor shall pay to any subsubcontractor or material supplier all retainages due the subsubcontractor or material supplier within ten (10) days after receipt of the retainages.

(c) Any default in the making of the payments shall be subject to those remedies provided in this part.

(d) In the event that an owner or prime contractor withholds retainage that is for the use and benefit of the prime contractor or its subcontractors pursuant to § 66-34-104(a) and (b), neither the prime contractor nor any of its subcontractors shall be required to deposit additional retained funds into an escrow account in accordance with § 66-34-104(a) and (b).

(e) (1) It is an offense for a person, firm or corporation to fail to comply with subsection (a) or (b) or § 66-34-104(a).

(2) (A) A violation of this subsection (e) is a Class A misdemeanor, subject to a fine only of three thousand dollars (\$3,000).

(B) Each day a person, firm or corporation fails to comply with subsection (a) or (b) or § 66-34-104(a) is a separate violation of this subsection (e).

(C) Until the violation of this subsection (e) is remediated by compliance, the punishment for each violation shall be consecutive to all other such violations.

(3) In addition to the fine imposed pursuant to subdivisions (e)(2)(A) and (B), the court shall order restitution be made to the owner of the retained funds. In determining the appropriate amount of restitution, the formula stated in § 40-35-304 shall be used.

HISTORY: Acts 2007, ch. 201, § 3; 2008, ch. 804, § 3; 2012, ch. 609, § 1.

Tenn. Code Ann. § 66-34-103

*** Current through the 2015 Regular Session ***

Title 66 Property
Chapter 34 Prompt Pay Act
Part 1 General Provisions

Tenn. Code Ann. § 66-34-104 (2016)

66-34-104. Retention of portion of contract price in escrow -- Applicability -- Mandatory compliance.

(a) Whenever, in any contract for the improvement of real property, a certain amount or percentage of the contract price is retained, that retained amount shall be deposited in a separate, interest-bearing, escrow account with a third party which must be established upon the withholding of any retainage.

(b) As of the time of the withholding of the retained funds, the funds shall become the sole and separate property of the prime contractor or remote contractor to whom they are owed, subject to the rights of the person withholding the retainage in the event the prime contractor or remote contractor otherwise entitled to the funds defaults on or does not complete its contract.

(c) In the event that the party withholding the retained funds fails to deposit the funds into an escrow account as provided herein, such party shall be responsible for paying the owner of the retained funds an additional three hundred dollar (\$300) penalty per day for each and every day that such retained funds are not deposited into such escrow account.

(d) The party with the responsibility for depositing the retained amount in a separate, interest-bearing, escrow account with a third party shall have the affirmative duty to provide written notice that it has complied with the requirements of this section to any prime contractor upon withholding the amount of retained funds from each and every application for payment, including:

(1) Identification of the name of the financial institution with whom the escrow account has been established;

(2) Account number; and

(3) Amount of retained funds that are deposited in the escrow account with the third party.

(e) Upon satisfactory completion of the contract, to be evidenced by a written release by the owner or prime contractor owing the retainage, all funds accumulated in the escrow account together with all interest on the account shall be paid immediately to the prime contractor or remote contractor to whom the funds and interest are owed.

(f) In the event the owner or prime contractor, as applicable, fails or refuses to execute the release provided for in subsection (c), then the prime contractor or remote contractor, as applicable, may seek any remedy in a court of proper jurisdiction and the person holding the fund as escrow agent shall bear no liability for the nonpayment of the fund to the prime contractor or remote contractor; provided, however, that all claims, demands, disputes, controversies, and differences that may arise between the owner, prime contractor or prime contractors, and remote contractor or remote contractors regarding the funds may be, upon written agreement of all parties concerned, settled by arbitration conducted pursuant to the Tennessee Uniform Arbitration Act, compiled in title 4, chapter 5, part 3, or the Federal Arbitration Act (9 U.S.C. § 1, et seq.), as may be applicable.

(g) In contracts to which the state or any department, board or agency of the state, including the University of Tennessee, is a party, interest shall be paid on the retained amounts at the same rate interest is paid on the funds of local governments participating in the local government investment pool established pursuant to § 9-4-704, for the contract period.

(h) This section shall be applicable to the state, any department, board or agency of the state, including the University of Tennessee, and all counties and municipalities and all departments, boards or agencies of the counties and municipalities, including all school and education boards, and any other subdivision of the state.

(i) This section shall be applicable to all prime contracts and all subcontracts thereunder for the improvement of real property when the contract amount of such prime contract is five hundred thousand dollars (\$500,000) or greater, notwithstanding the amount of such subcontracts.

(j) Compliance with this section shall be mandatory, and may not be waived by contract.

(k) Failure to deposit the retained funds into an escrow account as provided herein, within seven (7) days' receipt of written notice regarding such failure, is a Class A misdemeanor.

HISTORY: Acts 1975, ch. 345, §§ 1-4; T.C.A., §§ 64-1148 -- 64-1151; Acts 1985, ch. 340, §§ 1, 2; 1986, ch. 551, § 9; 2007, ch. 189, § 43; 2007, ch. 201, §§ 1, 2; T.C.A. § 66-11-144; Acts 2008, ch. 804, §§ 1, 2; 2010, ch. 875, §§ 1, 2; 2012, ch. 609, §§ 2-5.

Tenn. Code Ann. § 66-34-104

TENNESSEE CODE ANNOTATED
© 2016 by The State of Tennessee
All rights reserved

*** Current through the 2015 Regular Session ***

Title 66 Property
Chapter 34 Prompt Pay Act
Part 2 Owner/Contractor Payment

Tenn. Code Ann. § 66-34-203 (2016)

66-34-203. Withholding of payment or retainage by owner.

Nothing in this chapter shall prevent the owner from reasonably withholding payment or a portion of a payment to the contractor; provided, that such withholding is in accordance with the written contract between the owner and the contractor. The owner may also withhold a reasonable amount of retainage as specified in the written contract between the owner and the contractor; provided, however, that the retainage amount may not exceed five percent (5%) of the amount of the contract.

HISTORY: Acts 1991, ch. 45, § 1; 2007, ch. 201, § 4.

Tenn. Code Ann. § 66-34-203

ADVERTISEMENT FOR BIDS EXAMPLE – DBE

The {City/Town/County/Utility District/Authority} will receive separate sealed BIDS for the construction of a {water or wastewater} project at {location to deliver bid proposal} until {closing time}, local time, on {date}, and, then, at said time, publicly open and read the BIDS aloud.

The work to be bid on is as follows: {Description of work to be performed here.}

The allotted time for construction is {# of days for work to be performed} calendar days.

The information for Bidders; Bid Form; Form of Agreement; Drawings; Specifications information; Bid Bond, Performance Bond, and Payment Bond information; and other contract documents may be examined at the addresses below:

{Please type address of consulting engineer's office}

{Please type address of City/Town/Utility District/Authority}

Builder's Exchange of Tennessee

Nashville Office

Knoxville Office

2322 Winford Ave.

300 Clark Street

Nashville, TN 37211

Knoxville, TN 37921

Copies of the CONTRACT DOCUMENTS may be obtained at the {name of office to pick up contract documents} Office, located at {address of office}, upon payment of \$ {Amount} for each set.

Any BIDDER, upon returning the CONTRACT DOCUMENTS within {number of days} days after BID opening and in good condition, will be refunded {his/her payment or \$ amount} and any non-bidder will be refunded \$ {Amount}.

No bid may be withdrawn within (#) days after the scheduled time for receipt of bids.

DAVIS-BACON ACT REQUIREMENTS

This project is being funded by a State Revolving Fund loan on or after 2010 EPA Fiscal Year. The loan recipient must be in compliance with all applicable Davis-Bacon Act.

DISADVANTAGED BUSINESS ENTERPRISES (DBE) REQUIREMENTS

Any contract or contracts awarded by the Owner through this invitation for bids will be funded by a State Revolving Fund (SRF) loan from the State of Tennessee. State and Federal funds will be involved in this project, and, as a result, Bidders must comply with the SRF Loan Program's Disadvantaged Business Enterprises (DBE) requirements including contacting a minimum of 10 qualified DBE sub-contractors, professional service providers, vendors, and/or suppliers by certified mail to solicit bids. The apparent successful Bidder must submit to the Owner copies of the certified letters and return receipts prior to contract award. Neither the State of Tennessee nor any of its departments, agencies, or employees is or will be a party to this Invitation for Bids or any resulting contract(s) awarded by the Owner.

SPECIAL NOTICE TO DISADVANTAGED BUSINESS ENTERPRISES (DBE) FIRMS

All qualified Disadvantaged Business Enterprises (DBE) firms desiring to bid as a General Contractor, sub-contractor, professional service provider, supplier, or equipment vendor are encouraged to contact {Name of the Engineer, office address, and phone number}, in order to obtain a list of prospective bidding General Contractors or to obtain copies of bidding/contract documents.

**Disadvantaged Business Enterprise (DBE) Requirements
for**

State Revolving Fund Loans Awarded after March 7, 2016

GUIDANCE DOCUMENT

Items included in the Guidance Document:

- **General Contract Administration Provisions Table**
- **Six Good Faith Efforts, Purpose and Definitions Table**
- **List of DBE Forms for Loans Awarded After March 7, 2016**

GENERAL CONTRACT ADMINISTRATION PROVISIONS—www.epa.gov			
Requirement	Circumstance	Responsible Party:	Submitted To:
A Loan Recipient must be notified in writing by its Prime Contractor prior to any termination of a DBE Subcontractor for convenience by the Prime Contractor .	Termination of a DBE Subcontractor for convenience by the Prime Contractor	Prime Contractor	Loan Recipient
A Loan Recipient must require its Prime Contractor to pay its Subcontractor for satisfactory performance no more than 30 days from the Prime Contractor's receipt of payment from the Loan Recipient .	DBE Subcontractor's satisfactory performance	Loan Recipient Prime Contractor	DBE Subcontractor
If a DBE Subcontractor fails to complete work under the subcontract for any reason, the Loan Recipient must require the Prime Contractor to employ the Six Good Faith Efforts (see Table below) if soliciting a replacement Subcontractor .	DBE Subcontractor fails to complete work under the subcontract for any reason and will be replaced	Loan Recipient Prime Contractor	SRF Loan Program
A Loan Recipient must require its Prime Contractor to employ the Six Good Faith Efforts (see Table below) even if the Prime Contractor has achieved its fair share objectives.	Employment of the Six Good Faith Efforts	Loan Recipient Prime Contractor	SRF Loan Program
Inclusion, completion, and/or transmittal of required DBE Forms as instructed below: Loan Recipient Requirements Bidder Requirements DBE Participation/Certification Summary Advertisement for Bids and Publisher's Affidavit 10 Certified Letters and Return Receipts to certified DBEs Good Faith Letter Prime Contractor's Notice Letter for	---	Loan Recipient Prime Contractor DBE Subcontractor	See instructions below and on Forms

**Disadvantaged Business Enterprise (DBE) Requirements
for**

State Revolving Fund Loans Awarded after March 7, 2016

GUIDANCE DOCUMENT

SIX GOOD FAITH EFFORTS—www.epa.gov	
PURPOSE	The Good Faith Efforts are required methods employed by all EPA financial assistance agreement recipients to ensure that all disadvantaged business enterprises (DBEs) have the opportunity to compete for procurements funded by EPA financial assistance dollars.
Definitions	
EFFORT 1	Ensure DBEs are made aware of contracting opportunities to the fullest extent practicable through outreach and recruitment activities. For Indian Tribal, State and Local and Government recipients, this will include placing DBEs on solicitation lists and soliciting them whenever they are potential sources.
EFFORT 2	Make information on forthcoming opportunities available to DBEs and arrange time frames for contracts and establish delivery schedules, where the requirements permit, in a way that encourages and facilitates participation by DBEs in the competitive process. This includes, whenever possible, posting solicitations for bids or proposals for a minimum of 30 calendar days before the bid or proposal closing date.
EFFORT 3	Consider in the contracting process whether firms competing for large contracts could subcontract with DBEs. For Indian Tribal, State and local Government recipients, this will include dividing total requirements when economically feasible into smaller tasks or quantities to permit maximum participation by DBEs in the competitive process.
EFFORT 4	Encourage contracting with a consortium of DBEs when a contract is too large for one of these firms to handle individually.
EFFORT 5	Use the services and assistance of the Small Business Administration (SBA) and the Minority Business Development Agency of the Department of Commerce.
EFFORT 6	If the Prime Contractor awards subcontracts, require the Prime Contractor to take the steps in the Good Faith Efforts 1 through 5 (above) and in the <u>General Contract Administration Provisions</u> (above).

**Disadvantaged Business Enterprise (DBE) Requirements
for**

State Revolving Fund Loans Awarded after March 7, 2016

GUIDANCE DOCUMENT

DBE FORMS FOR SRF LOANS AWARDED AFTER MARCH 7, 2016—www.epa.gov				
Form	Requirement	Provided By:	Completed By:	Submitted To:
List of certified DBE contractors, subcontractors, supplies vendors, equipment vendors, and service providers	Keep list with project files/information for duration of project	SRF Loan Program	---	---
Loan Recipient's Requirements regarding DBEs	Include this information sheet in the Information for Bidders section of bid documents	SRF Loan Program	---	To be included in the contract specifications book
Bidder's Requirements regarding DBEs	Include this information sheet in the Information for Bidders section of bid documents	SRF Loan Program	---	To be included in the contract specifications book
Loan Recipient's Certification and Summary of DBE Participation	To be completed and submitted with the Authority-to-Award/ Bid Package. The SRF Loan Program must be notified of any changes, additions, or deletions to the contract during construction.	SRF Loan Program	Loan Recipient	SRF Loan Program
Advertisement for Bids and Publisher's Affidavit	DBE solicitation information must be included in the actual advertisement for bids. A Publisher's Affidavit (signed, original, notarized certification of publication) denoting the actual published date of the advertisement will be submitted to the SRF Loan Program as part of the Authority-to-Award/Bid Package documents.	An example advertisement with appropriate DBE language is supplied to the Loan Recipient by the SRF Loan Program	Loan Recipient	A copy of the actual advertisement and a Publisher's Affidavit will be submitted to the SRF Loan Program as part of the Authority-to-Award/Bid Package documents
10 Certified Letters and Return Receipts to potential certified DBE subcontractors, supplies vendors, service providers, and/or equipment vendors	These certified letters and copies of the corresponding return mail receipts are submitted with the completed Loan Recipient's DBE Participation and Certification Summary Form.	Prime Contractor and/or Loan Recipient	Loan Recipient	SRF Loan Program as part of the Authority-to-Award/Bid Package documents
Good Faith Letter	If no DBE participation is obtained for the contract, the "Good Faith" letter must be written.	Form letter provided by the SRF Loan Program	Loan Recipient	SRF Loan Program

STATE REVOLVING FUND LOAN PROGRAM

Loan Recipient's Requirements for Solicitation and Documentation **of** **Disadvantaged Business Enterprises (DBE) Participation** on State Revolving Fund (SRF) Projects

A goal-oriented system has been established to promote **Disadvantaged Business Enterprises (DBE)** participation by providing construction services, professional services, supplies, and/or equipment on SRF Loan-funded water and wastewater projects. It is the Loan Recipient's responsibility to ensure that Bidders make a good faith effort during the bidding phase to solicit for subcontractor participation by **DBE** subcontractors, service professionals, suppliers, and/or equipment vendors on all SRF-funded projects.

DEFINITIONS

DBE - Minority Business Enterprise (MBE): A qualified socially and economically disadvantaged minority-owned business certified by any State or Federal agency, such as the Tennessee Department of Transportation, U.S. EPA's Office of Small and Disadvantaged Business Utilization, or the U.S. Small Business Administration.

DBE - Women's Business Enterprise (WBE): A qualified independent business at least 51% owned by a woman or women and certified by any State or Federal agency such as the Tennessee Department of Transportation, U.S. EPA's Office of Small and Disadvantaged Business Utilization, or the U.S. Small Business Administration.

Fair-Share Goals: The MBE fair-share goal is 2.6% for construction and 5.2% for supplies, services, and equipment. The WBE fair share goal is 2.6% for construction and 5.2% for supplies, services, and equipment.

INSTRUCTIONS TO LOAN RECIPIENTS

Pre-Bid Requirements

Loan Recipients must include the SRF Loan Program's "Bidder's Requirements for Solicitation and Documentation of **DBE** Participation on SRF-Funded Projects" information sheet in the Information for Bidders section of bid documents. Loan Recipients must also ensure that Bidders take the following affirmative steps that constitute a good-faith effort to secure **DBE** participation:

- Include certified **DBEs** on solicitation lists whenever they are potential sources,
- Divide construction contracts into subcontracts, when economically feasible, to encourage maximum participation by **DBEs**,
- Establish delivery schedules, where requirements of the work permit, that encourage participation by **DBEs**,
- Use the services and assistance of the Office of Minority Business Enterprises of the U.S. Department of Commerce, or the U.S. EPA's Office of Small and Disadvantaged Business Utilization. For assistance or information, Bidders may be referred to:

Tennessee Department of Transportation
Small Business Development
505 Deaderick Street, Suite 1800
Nashville, TN 37243-0347
(615) 741-3681

http://www.tdot.state.tn.us/construction/DBE%20list/dbe_list.pdf

Mr. W. Clinton Smith, District Director
U.S. Small Business Administration
50 Vantage Way, Suite 201
Nashville, TN 37228
(615) 736-5881

<http://pro-net.sba.gov/>

Ms. Jeanette L. Brown, Director
U.S. Environmental Protection Agency
Office of Small and Disadvantaged Business Utilization
1200 Pennsylvania Avenue, N.W. (1230A)
Washington, D.C. 20460
(202) 564-4100

<http://www.epa.gov/osdbu/>

POST-BID REQUIREMENTS

Whether or not DBE participation was obtained, the Loan Recipient must complete the "**Loan Recipient's Certification and Summary**" form for every contract detailing whether or not **DBE** participation of subcontractors, professional service providers, suppliers, and/or equipment vendors was obtained. The "**Loan Recipient's Certification and Summary**" form must be submitted to the Administrative Section of the SRF Loan Program prior to the award of any construction contract(s) along with the newspaper **advertisement**, a **Publisher's Affidavit**, and **return receipts** and copies of the **certified letters** that were mailed to a minimum of 10 qualified DBEs.

STATE REVOLVING FUND LOAN PROGRAM

Loan Recipient's Requirements for Solicitation and Documentation
of
Disadvantaged Business Enterprises (DBE) Participation
on State Revolving Fund (SRF) Projects

If DBE participation was obtained, the “Loan Recipient’s Certification and Summary” form must clearly indicate whether **DBE** participation was obtained from either a subcontractor, professional service provider, supplier, and/or equipment vendor participation; identify the **DBE** firm(s) to be used; and certify that the **DBE** firm(s) is a certified **DBE**.

If no DBE participation was obtained, the Loan Recipient must submit a separate letter documenting that a “good-faith effort” was made to secure **DBE** participation. This letter is submitted along with the above-mentioned “Loan Recipient’s Certification and Summary” form, newspaper advertisement, Publisher’s Affidavit, return receipts, and copies of the certified letters. The SRF Loan Program provides a template to the Loan Recipient for this letter.

This documentation is the only form of documentation that will be accepted by the SRF Loan Program. Failure to provide the required documentation may result in a delay of the SRF Loan Program’s approval of the Authority-to-Award/Bid Package, thereby delaying the award of the construction contract(s).

The Loan Recipient should direct all inquiries regarding the SRF Loan Program’s requirements for **DBE** solicitation and documentation to Dr. Bagher Sami at (615) 532-0501, bagher.sami@tn.gov, or the following address:

Dr. Bagher Sami, Manager
Administrative and Financial Section
Tennessee State Revolving Fund Loan Program
WRS - Tennessee Tower, 12th Floor
312 Rosa L. Parks Avenue
Nashville, TN 37243

STATE REVOLVING FUND LOAN PROGRAM

Loan Recipient's Good Faith Effort Letter for DBE Participation

(Insert on Loan Recipient's Letterhead)

(Date)

Dr. Bagher Sami, Manager
Administrative and Financial Sections
State Revolving Fund Loan Program
William R. Snodgrass Tennessee Tower
312 Rosa L. Parks Avenue, 12th Floor
Nashville, TN 37243

RE: Good Faith Effort – Disadvantaged Business Enterprises (DBE) Participation
City/County/UD/Authority (?? County), Tennessee
Loan No. SRF/CWA/CGA/DWF/DWA/DGA 20??-???
Contract No. ????, Contract Description

Dear Dr. Sami:

This letter is to inform you that the **City/County/UD/Authority** did, in good faith, encourage Disadvantaged Business Enterprises (DBE) to participate in the above referenced project by placing a special notice to Disadvantaged Business Enterprises (DBE) firms in both the invitation to bid and the public advertisement for bids. The **City/County/UD/Authority**, through the consulting engineer, **(A/E Consulting Firm)**, sent a copy of the invitation to bid and a set of contract documents to the Office of Minority Business Enterprises. The **City/County/UD/Authority** also sent certified letters, return receipts requested, to a minimum of ten (10) DBE potential subcontractors, professional service providers, suppliers, and equipment vendors requesting DBE participation through their office, A/E, or their contractor. The consulting engineer on this project is **(Name), (Firm)**.

We have not received any DBE participation; we believe we have done a good faith effort.

If you have any questions, please don't hesitate to contact us.

Sincerely,

(Authorized Representative Name)

(Authorized Representative Title)

cc: **(A/E Consultant Name and Firm)**

STATE REVOLVING FUND LOAN PROGRAM

Loan Recipient's Certification and Summary

of

Disadvantaged Business Enterprises (DBE) Participation

SRF Loan Recipient: _____ SRF Loan No. _____

INSTRUCTIONS TO SRF LOAN RECIPIENTS

The SRF Loan Recipient's Authorized Representative must clearly indicate the Contractor's **Disadvantaged Business Enterprises (DBE)** participation results by placing a check in the appropriate box below. The remainder of the form must be completed if **DBE (Minority Business Enterprise-MBE or Women's Business Enterprise -WBE)** participation was obtained. The form must be signed and dated and returned to Dr. Bagher Sami of the Administrative Section of the SRF Loan Program.

The **completed Form** must be accompanied by **copies of the certified letters** sent from the selected Bidder to a minimum of 10 qualified **DBE** potential subcontractors, supplies vendor, services provider, and/or equipment vendors, and **copies of the corresponding return mail receipts**.

The SRF Loan Program must be notified of any changes, additions, or deletions to the contract during construction.

No, Disadvantaged Business Enterprises (DBE) participation was not obtained for this SRF-funded project. I certify that a good-faith effort was made to solicit **DBE** participation in accordance with the four affirmative steps outlined in the SRF Loan Program's Requirements for Solicitation and Documentation of **DBE** Participation on SRF-Funded Projects. A letter documenting that a good-faith effort was made to secure **DBE** participation has been provided to the SRF Loan Program.

OR

Yes, Disadvantaged Business Enterprises (DBE) participation was obtained for this SRF-funded project. I certify that the **DBE** firms participating in this SRF-funded project are qualified in accordance with the SRF Loan Program's Requirements for Solicitation and Documentation of **DBE** Participation on SRF-Funded Projects. Below is a listing of firms to be utilized and the amounts of their respective participation.

1. **DBE type (circle one):** Subcontractor, Supplies Vendor, Service Provider, Equipment Vendor
DBE Name: _____
Address: _____
Subcontract Amount: \$ _____ MBE ___ WBE ___ % of Contract \$: _____ %

2. **DBE type (circle one):** Subcontractor, Supplies Vendor, Service Provider, Equipment Vendor
DBE Name: _____
Address: _____
Subcontract Amount: \$ _____ MBE ___ WBE ___ % of Contract \$: _____ %

3. **DBE type (circle one):** Subcontractor, Supplies Vendor, Service Provider, Equipment Vendor
DBE Name: _____
Address: _____
Subcontract Amount: \$ _____ MBE ___ WBE ___ % of Contract \$: _____ %

4. **DBE type (circle one):** Subcontractor, Supplies Vendor, Service Provider, Equipment Vendor
DBE Name: _____
Address: _____
Subcontract Amount: \$ _____ MBE ___ WBE ___ % of Contract \$: _____ %

PARTICIPATION SUMMARY

Total SRF Loan Amount: \$ _____ **Total Construction Contract Amount:** \$ _____
Total MBE Participation: \$ _____ **Total WBE Participation:** \$ _____

Signature and Title of SRF Loan Recipient's Authorized Representative

Date

STATE REVOLVING FUND LOAN PROGRAM

Bidder's Requirements for Solicitation and Documentation **of** **Disadvantaged Business Enterprises (DBE) Participation**

A goal-oriented system has been established to promote **Disadvantaged Business Enterprises (DBE)** participation by providing construction services, professional services, supplies, and/or equipment on SRF Loan-funded water and wastewater projects. It is the Bidder's responsibility to make a good faith effort to secure participation by **DBE** subcontractors, professional service providers, suppliers, and/or equipment vendors.

DEFINITIONS

DBE - Minority Business Enterprise (MBE): A qualified socially and economically disadvantaged minority-owned business certified by any State or Federal agency, such as the Tennessee Department of Transportation, U.S. EPA's Office of Small and Disadvantaged Business Utilization, or the U.S. Small Business Administration.

DBE - Women's Business Enterprise (WBE): A qualified independent business at least 51% owned by a woman or women and certified by any State or Federal agency such as the Tennessee Department of Transportation, U.S. EPA's Office of Small and Disadvantaged Business Utilization, or the U.S. Small Business Administration.

Fair-Share Goals: The MBE fair-share goal is 2.6% for construction and 5.2% for supplies, services, and equipment. The WBE fair share goal is 2.6% for construction and 5.2% for supplies, services, and equipment.

INSTRUCTIONS TO BIDDERS

Pre-Bid Requirements

All Bidders must send letters by certified mail with return receipt requested to a minimum of 10 certified **DBE** subcontractors, professional service providers, suppliers, and/or equipment vendors to solicit their subcontract participation in the work. Lists of certified **DBE** firms may be obtained from various State and Federal agencies, including the following:

Tennessee Department of Transportation
Small Business Development
505 Deaderick Street, Suite 1800
Nashville, TN 37243-0347
(615) 741-3681
<http://www.tdot.state.tn.us/dbedirectinternet/Vendor.aspx>

Mr. W. Clinton Smith, District Director
U.S. Small Business Administration
50 Vantage Way, Suite 201
Nashville, TN 37228
(615) 736-5881
<http://pro-net.sba.gov/>

U.S. Environmental Protection Agency
Office of Small and Disadvantaged Business Utilization
1200 Pennsylvania Avenue, N.W. (1230A)
Washington, D.C. 20460
(202) 564-4100
<http://www.epa.gov/osdbu/>

Post-Bid Requirements

Whether or not DBE participation was obtained, the successful Bidder (Prime Contractor) must maintain supporting documents such as certification lists, solicitation documents, letters of intent, contracts, etc., for the duration of the project.

If DBE participation was obtained, the apparent successful Bidder must identify to the Loan Recipient all **DBE** firms to be utilized on the contract and the respective **DBE** type--subcontractors, supplies vendors, service providers, and/or equipment vendors (see "Loan Recipient's Certification and Summary" form). Copies of the State's or Federal agency's **DBE** certification list(s) identifying that the **DBE** firms are certified minority or women's business enterprises must be provided to the Loan Recipient.

If no DBE participation was obtained by the apparent successful Bidder, it remains the responsibility of the Prime Contractor to provide documentation to the Loan Recipient, prior to contract award, that a good faith effort was made to obtain **DBE** participation. Copies of the **certified letters** sent to a minimum of 10 qualified **DBE** potential subcontractors, supplies vendors, service providers, and/or equipment vendors and the corresponding **return mail receipts** are the only documentation of a good-faith effort that will be acceptable to the Loan Recipient.

*Failure to provide the required certified letters, return receipts, State or Federal agency **DBE** certification list(s), to the Loan Recipient may delay the contract award until the required documentation has been provided to and accepted by the Loan Recipient.*

Certified Disadvantaged Business Enterprises (DBE) List

Using Governor's Diversity Business Office and State DOT and CCR DBE Directories to Find Certified WBEs and MBEs

Here are the links:

<https://tn.diversitysoftware.com/FrontEnd/VendorSearchPublic.asp?TN=tn&XID=1215>

www.osdbu.dot.gov/DBEProgram/StateDOTDBESites.cfm

CCR can be used to search for SBA SDBs. Since the SBA SDB certification is considered acceptable under the EPA DBE Program, firms found using the following search criteria can count toward EPA MBE/WBE fair share objectives.

Access the CCR search page at www.bpn.gov/CCRSearch/Search.aspx

http://www.epa.gov/osbp/dbe_team.htm

OPERATOR:		
Backhoe/Excavator/Trackhoe.....	\$ 16.82	0.00
OPERATOR: Loader.....	\$ 13.50	0.00
TRUCK DRIVER: Dump Truck.....	\$ 10.76	0.00

WELDERS - Receive rate prescribed for craft performing operation to which welding is incidental.

=====

Note: Executive Order (EO) 13706, Establishing Paid Sick Leave for Federal Contractors applies to all contracts subject to the Davis-Bacon Act for which the contract is awarded (and any solicitation was issued) on or after January 1, 2017. If this contract is covered by the EO, the contractor must provide employees with 1 hour of paid sick leave for every 30 hours they work, up to 56 hours of paid sick leave each year. Employees must be permitted to use paid sick leave for their own illness, injury or other health-related needs, including preventive care; to assist a family member (or person who is like family to the employee) who is ill, injured, or has other health-related needs, including preventive care; or for reasons resulting from, or to assist a family member (or person who is like family to the employee) who is a victim of, domestic violence, sexual assault, or stalking. Additional information on contractor requirements and worker protections under the EO is available at www.dol.gov/whd/govcontracts.

Unlisted classifications needed for work not included within the scope of the classifications listed may be added after award only as provided in the labor standards contract clauses (29CFR 5.5 (a) (1) (ii)).

The body of each wage determination lists the classification and wage rates that have been found to be prevailing for the cited type(s) of construction in the area covered by the wage determination. The classifications are listed in alphabetical order of "identifiers" that indicate whether the particular rate is a union rate (current union negotiated rate for local), a survey rate (weighted average rate) or a union average rate (weighted union average rate).

Union Rate Identifiers

A four letter classification abbreviation identifier enclosed in dotted lines beginning with characters other than "SU" or "UAVG" denotes that the union classification and rate were prevailing for that classification in the survey. Example: PLUM0198-005 07/01/2014. PLUM is an abbreviation identifier of the union which prevailed in the survey for this classification, which in this example would be Plumbers. 0198 indicates the local union number or district council number

where applicable, i.e., Plumbers Local 0198. The next number, 005 in the example, is an internal number used in processing the wage determination. 07/01/2014 is the effective date of the most current negotiated rate, which in this example is July 1, 2014.

Union prevailing wage rates are updated to reflect all rate changes in the collective bargaining agreement (CBA) governing this classification and rate.

Survey Rate Identifiers

Classifications listed under the "SU" identifier indicate that no one rate prevailed for this classification in the survey and the published rate is derived by computing a weighted average rate based on all the rates reported in the survey for that classification. As this weighted average rate includes all rates reported in the survey, it may include both union and non-union rates. Example: SULA2012-007 5/13/2014. SU indicates the rates are survey rates based on a weighted average calculation of rates and are not majority rates. LA indicates the State of Louisiana. 2012 is the year of survey on which these classifications and rates are based. The next number, 007 in the example, is an internal number used in producing the wage determination. 5/13/2014 indicates the survey completion date for the classifications and rates under that identifier.

Survey wage rates are not updated and remain in effect until a new survey is conducted.

Union Average Rate Identifiers

Classification(s) listed under the UAVG identifier indicate that no single majority rate prevailed for those classifications; however, 100% of the data reported for the classifications was union data. EXAMPLE: UAVG-OH-0010 08/29/2014. UAVG indicates that the rate is a weighted union average rate. OH indicates the state. The next number, 0010 in the example, is an internal number used in producing the wage determination. 08/29/2014 indicates the survey completion date for the classifications and rates under that identifier.

A UAVG rate will be updated once a year, usually in January of each year, to reflect a weighted average of the current negotiated/CBA rate of the union locals from which the rate is based.

WAGE DETERMINATION APPEALS PROCESS

1.) Has there been an initial decision in the matter? This can be:

- * an existing published wage determination
- * a survey underlying a wage determination
- * a Wage and Hour Division letter setting forth a position on a wage determination matter

* a conformance (additional classification and rate) ruling

On survey related matters, initial contact, including requests for summaries of surveys, should be with the Wage and Hour Regional Office for the area in which the survey was conducted because those Regional Offices have responsibility for the Davis-Bacon survey program. If the response from this initial contact is not satisfactory, then the process described in 2.) and 3.) should be followed.

With regard to any other matter not yet ripe for the formal process described here, initial contact should be with the Branch of Construction Wage Determinations. Write to:

Branch of Construction Wage Determinations
Wage and Hour Division
U.S. Department of Labor
200 Constitution Avenue, N.W.
Washington, DC 20210

2.) If the answer to the question in 1.) is yes, then an interested party (those affected by the action) can request review and reconsideration from the Wage and Hour Administrator (See 29 CFR Part 1.8 and 29 CFR Part 7). Write to:

Wage and Hour Administrator
U.S. Department of Labor
200 Constitution Avenue, N.W.
Washington, DC 20210

The request should be accompanied by a full statement of the interested party's position and by any information (wage payment data, project description, area practice material, etc.) that the requestor considers relevant to the issue.

3.) If the decision of the Administrator is not favorable, an interested party may appeal directly to the Administrative Review Board (formerly the Wage Appeals Board). Write to:

Administrative Review Board
U.S. Department of Labor
200 Constitution Avenue, N.W.
Washington, DC 20210

4.) All decisions by the Administrative Review Board are final.

=====

END OF GENERAL DECISION

□

EMPLOYEE RIGHTS UNDER THE DAVIS-BACON ACT

FOR LABORERS AND MECHANICS EMPLOYED ON FEDERAL OR FEDERALLY ASSISTED CONSTRUCTION PROJECTS

THE UNITED STATES DEPARTMENT OF LABOR WAGE AND HOUR DIVISION

PREVAILING WAGES

You must be paid not less than the wage rate listed in the Davis-Bacon Wage Decision posted with this Notice for the work you perform.

OVERTIME

You must be paid not less than one and one-half times your basic rate of pay for all hours worked over 40 in a work week. There are few exceptions.

ENFORCEMENT

Contract payments can be withheld to ensure workers receive wages and overtime pay due, and liquidated damages may apply if overtime pay requirements are not met. Davis-Bacon contract clauses allow contract termination and debarment of contractors from future federal contracts for up to three years. A contractor who falsifies certified payroll records or induces wage kickbacks may be subject to civil or criminal prosecution, fines and/or imprisonment.

APPRENTICES

Apprentice rates apply only to apprentices properly registered under approved Federal or State apprenticeship programs.

PROPER PAY

If you do not receive proper pay, or require further information on the applicable wages, contact the Contracting Officer listed below:

or contact the U.S. Department of Labor's Wage and Hour Division.



For additional information:

1-866-4-USWAGE

(1-866-487-9243) TTY: 1-877-889-5627



WWW.WAGEHOUR.DOL.GOV

DERECHOS DEL EMPLEADO BAJO LA LEY DAVIS-BACON

PARA OBREROS Y MECÁNICOS EMPLEADOS EN PROYECTOS DE CONSTRUCCIÓN FEDERAL O CON ASISTENCIA FEDERAL

LA SECCIÓN DE HORAS Y SUELDOS DEL DEPARTAMENTO DE TRABAJO DE EEUU

SALARIOS PREVALECIENTES

No se le puede pagar menos de la tasa de pago indicada en la Decisión de Salarios Davis-Bacon fijada con este Aviso para el trabajo que Ud. desempeña.

SOBRETIEMPO

Se le ha de pagar no menos de tiempo y medio de su tasa básica de pago por todas las horas trabajadas en exceso de 40 en una semana laboral. Existen pocas excepciones.

CUMPLIMIENTO

Se pueden retener pagos por contratos para asegurarse que los obreros reciban los salarios y el pago de sobretiempo debidos, y se podría aplicar daños y perjuicios si no se cumple con las exigencias del pago de sobretiempo. Las cláusulas contractuales de Davis-Bacon permiten la terminación y exclusión de contratistas para efectuar futuros contratos federales hasta tres años. El contratista que falsifique los registros certificados de las nóminas de pago o induzca devoluciones de salarios puede ser sujeto a procesamiento civil o criminal, multas y/o encarcelamiento.

APRENDICES

Las tasas de aprendices sólo se aplican a aprendices correctamente inscritos bajo programas federales o estatales aprobados.

PAGO APROPIADO

Si Ud. no recibe el pago apropiado, o precisa de información adicional sobre los salarios aplicables, póngase en contacto con el Contratista Oficial que aparece abajo:

o póngase en contacto con la Sección de Horas y Sueldos del Departamento de Trabajo de EEUU.



Para obtener información adicional:

1-866-4-USWAGE

(1-866-487-9243) TTY: 1-877-889-5627



WWW.WAGEHOUR.DOL.GOV

Project Wage Rate Sheet

U.S. Department of Housing and Urban Development
Office of Labor Relations

PROJECT NAME:			WAGE DECISION NUMBER/MODIFICATION NUMBER:			
PROJECT NUMBER:			PROJECT COUNTY:			
WORK CLASSIFICATION	BASIC HOURLY RATE (BHR)	FRINGE BENEFITS	TOTAL HOURLY WAGE RATE	LABORERS FRINGE BENEFITS:		\$ TOTAL WAGE
				GROUP #	BHR	
Bricklayers			\$			\$
Carpenters			\$			\$
Cement Masons			\$			\$
Drywall Hangers			\$			\$
Electricians			\$			\$
Iron Workers			\$			\$
Painters			\$	OPERATORS FRINGE BENEFITS:		\$ TOTAL WAGE
				GROUP #	BHR	
Plumbers			\$			\$
Roofers			\$			\$
Sheet Metal Workers			\$			\$
Soft Floor Layers			\$			\$
Tapers			\$			\$
Tile Setters			\$	TRUCK DRIVERS FRINGE BENEFITS:		\$ TOTAL WAGE
				GROUP #	BHR	
OTHER CLASSIFICATIONS						
			\$			\$
			\$			\$
			\$			\$
ADDITIONAL CLASSIFICATIONS (HUD Form 4230-A)						
WORK CLASSIFICATION	BASIC HOURLY RATE	FRINGE BENEFITS	TOTAL HOURLY WAGE RATE	DATE OF HUD SUBMISSION TO DOL	DATE OF DOL APPROVAL	
			\$			
			\$			
			\$			
			\$			

STATE REVOLVING FUND LOAN PROGRAM

Bidder's Requirements

Davis-Bacon Act Wage Determination

The Loan Recipient must ensure the bidder is in compliance with the Davis-Bacon Act as outlined below. Additionally, ten (10) days prior to the scheduled bid opening date, the wage rates need to be checked to ensure they have not changed.

The Davis-Bacon Act as amended, requires that each contract over \$2,000 to which the United States or the District of Columbia is a party for the construction, alteration, or repair of public buildings or public works shall contain a clause setting forth the minimum wages to be paid to various classes of laborers and mechanics employed under the contract. Under the provisions of the Act, contractors or their subcontractors are to pay workers employed directly upon the site of the work no less than the locally prevailing wages and fringe benefits paid on projects of a similar character. The Davis-Bacon Act directs the Secretary of Labor to determine such local prevailing wage rates.

The **wage determination** (including any additional **classifications** and **wage rates** conformed) **and** a Davis-Bacon poster (WH-1321) **must be posted on the work site at all times** by the contractor and its subcontractors in a prominent and accessible place where it can be easily seen. The WH-1321 poster **may be obtained at no charge** from offices of the Wage and Hour Division.

With each **pay estimate** submitted, the contractors **must submit** a certification stating that workers have been paid the current prevailing wage rates for each classification according to the Davis-Bacon wage rate schedule currently in effect for this project.

Wage Determinations

A "wage determination" is the listing of wage rates and fringe benefit rates for each classification of laborers and mechanics which the Administrator of the Wage and Hour Division of the U.S. Department of Labor has determined to be prevailing in a given area for a particular type of construction (e.g., building, heavy, highway, or residential).

Extensions of Wage Determinations

When a general wage determination has not been awarded within 90 days after bid opening, the head of the contracting/assisting agency may request an extension of the 90 day period from the Wage and Hour Administrator. When, due to unavoidable circumstances, a project wage determination expires before award but after bid opening, the head of the contracting/assisting agency may request an extension of the expiration date of the project wage determination in the bid specifications instead of issuing a new wage determination.

Extension requests should be supported by a written finding including a brief statement of the factual support, that extension of the expiration date of the determination is necessary and proper in the public interest to prevent injustice or undue hardship or to avoid serious impairment in the conduct of Government business.

The Administrator of the Wage and Hour Division of the U.S. Department of Labor will either grant or deny the request for an extension after consideration of all the circumstances, including an examination to determine if the previously issued rates remain prevailing. If a request for the extension of a project wage determination is denied, a new wage determination will be issued to replace an expired project wage determination.

Additional information concerning the Davis-Bacon Act and current wage rate determinations can be obtained at the following sites: www.gpo.gov/davisbacon/referencemat.html and www.wdol.gov/.

STATE REVOLVING FUND LOAN PROGRAM

Wage Rate Requirements Under FY 2010 Appropriations

3. Contract and Subcontract provisions.

(a) The Recipient shall insure that the subrecipient(s) shall insert in full in any contract in excess of \$2,000 which is entered into for the actual construction, alteration and/or repair, including painting and decorating, of a treatment work under the CWSRF or a construction project under the DWSRF financed in whole or in part from Federal funds or in accordance with guarantees of a Federal agency or financed from funds obtained by pledge of any contract of a Federal agency to make a loan, grant or annual contribution (except where a different meaning is expressly indicated), and which is subject to the labor standards provisions of any of the acts listed in § 5.1 or the FY 2010 appropriation, the following clauses:

(1) Minimum wages.

(i) All laborers and mechanics employed or working upon the site of the work will be paid unconditionally and not less often than once a week, and without subsequent deduction or rebate on any account (except such payroll deductions as are permitted by regulations issued by the Secretary of Labor under the Copeland Act (29 CFR part 3)), the full amount of wages and bona fide fringe benefits (or cash equivalents thereof) due at time of payment computed at rates not less than those contained in the wage determination of the Secretary of Labor which is attached hereto and made a part hereof, regardless of any contractual relationship which may be alleged to exist between the contractor and such laborers and mechanics.

Contributions made or costs reasonably anticipated for bona fide fringe benefits under section 1(b)(2) of the Davis-Bacon Act on behalf of laborers or mechanics are considered wages paid to such laborers or mechanics, subject to the provisions of paragraph (a)(1)(iv) of this section; also, regular contributions made or costs incurred for more than a weekly period (but not less often than quarterly) under plans, funds, or programs which cover the particular weekly period, are deemed to be constructively made or incurred during such weekly period. Such laborers and mechanics shall be paid the appropriate wage rate and fringe benefits on the wage determination for the classification of work actually performed, without regard to skill, except as provided in § 5.5(a)(4). Laborers or mechanics performing work in more than one classification may be compensated at the rate specified for each classification for the time actually worked therein: Provided, That the employer's payroll records accurately set forth the time spent in each classification in which work is performed. The wage determination (including any additional classification and wage rates conformed under paragraph (a)(1)(ii) of this section) and the Davis-Bacon poster (WH-1321) shall be posted at all times by the contractor and its subcontractors at the site of the work in a prominent and accessible place where it can be easily seen by the workers.

Subrecipients may obtain wage determinations from the U.S. Department of Labor's web site, www.dol.gov.

(ii)(A) The subrecipient(s), on behalf of EPA, shall require that any class of laborers or mechanics, including helpers, which is not listed in the wage determination and which is to be employed under the contract shall be classified in conformance with the wage determination. The State award official shall approve a request for an additional classification and wage rate and fringe benefits therefore only when the following criteria have been met:

(1) The work to be performed by the classification requested is not performed by a classification in the wage determination; and

(2) The classification is utilized in the area by the construction industry; and

(3) The proposed wage rate, including any bona fide fringe benefits, bears a reasonable relationship to the wage rates contained in the wage determination.

STATE REVOLVING FUND LOAN PROGRAM

(B) If the contractor and the laborers and mechanics to be employed in the classification (if known), or their representatives, and the subrecipient(s) agree on the classification and wage rate (including the amount designated for fringe benefits where appropriate), documentation of the action taken and the request, including the local wage determination shall be sent by the subrecipient (s) to the State award official. The State award official will transmit the request, to the Administrator of the Wage and Hour Division, Employment Standards Administration, U.S. Department of Labor, Washington, DC 20210 and to the EPA DB Regional Coordinator concurrently. The Administrator, or an authorized representative, will approve, modify, or disapprove every additional classification request within 30 days of receipt and so advise the State award official or will notify the State award official within the 30-day period that additional time is necessary.

(C) In the event the contractor, the laborers or mechanics to be employed in the classification or their representatives, and the subrecipient(s) do not agree on the proposed classification and wage rate (including the amount designated for fringe benefits, where appropriate), the award official shall refer the request and the local wage determination, including the views of all interested parties and the recommendation of the State award official, to the Administrator for determination. The request shall be sent to the EPA DB Regional Coordinator concurrently. The Administrator, or an authorized representative, will issue a determination within 30 days of receipt of the request and so advise the contracting officer or will notify the contracting officer within the 30-day period that additional time is necessary.

(D) The wage rate (including fringe benefits where appropriate) determined pursuant to paragraphs (a)(1)(ii)(B) or (C) of this section, shall be paid to all workers performing work in the classification under this contract from the first day on which work is performed in the classification.

(iii) Whenever the minimum wage rate prescribed in the contract for a class of laborers or mechanics includes a fringe benefit which is not expressed as an hourly rate, the contractor shall either pay the benefit as stated in the wage determination or shall pay another bona fide fringe benefit or an hourly cash equivalent thereof.

(iv) If the contractor does not make payments to a trustee or other third person, the contractor may consider as part of the wages of any laborer or mechanic the amount of any costs reasonably anticipated in providing bona fide fringe benefits under a plan or program, Provided, That the Secretary of Labor has found, upon the written request of the contractor, that the applicable standards of the Davis-Bacon Act have been met. The Secretary of Labor may require the contractor to set aside in a separate account assets for the meeting of obligations under the plan or program.

(2) Withholding. The subrecipient(s), shall upon written request of the EPA Award Official or an authorized representative of the Department of Labor, withhold or cause to be withheld from the contractor under this contract or any other Federal contract with the same prime contractor, or any other federally-assisted contract subject to Davis-Bacon prevailing wage requirements, which is held by the same prime contractor, so much of the accrued payments or advances as may be considered necessary to pay laborers and mechanics, including apprentices, trainees, and helpers, employed by the contractor or any subcontractor the full amount of wages required by the contract. In the event of failure to pay any laborer or mechanic, including any apprentice, trainee, or helper, employed or working on the site of the work, all or part of the wages required by the contract, the (Agency) may, after written notice to the contractor, sponsor, applicant, or owner, take such action as may be necessary to cause the suspension of any further payment, advance, or guarantee of funds until such violations have ceased.

(3) Payrolls and basic records.

STATE REVOLVING FUND LOAN PROGRAM

(i) Payrolls and basic records relating thereto shall be maintained by the contractor during the course of the work and preserved for a period of three years thereafter for all laborers and mechanics working at the site of the work. Such records shall contain the name, address, and social security number of each such worker, his or her correct classification, hourly rates of wages paid (including rates of contributions or costs anticipated for bona fide fringe benefits or cash equivalents thereof of the types described in section 1(b)(2)(B) of the Davis-Bacon Act), daily and weekly number of hours worked, deductions made and actual wages paid. Whenever the Secretary of Labor has found under 29 CFR 5.5(a)(1)(iv) that the wages of any laborer or mechanic include the amount of any costs reasonably anticipated in providing benefits under a plan or program described in section 1(b)(2)(B) of the Davis-Bacon Act, the contractor shall maintain records which show that the commitment to provide such benefits is enforceable, that the plan or program is financially responsible, and that the plan or program has been communicated in writing to the laborers or mechanics affected, and records which show the costs anticipated or the actual cost incurred in providing such benefits. Contractors employing apprentices or trainees under approved programs shall maintain written evidence of the registration of apprenticeship programs and certification of trainee programs, the registration of the apprentices and trainees, and the ratios and wage rates prescribed in the applicable programs.

(ii)(A) The contractor shall submit weekly, for each week in which any contract work is performed, a copy of all payrolls to the subrecipient, that is, the entity that receives the sub-grant or loan from the State capitalization grant recipient. Such documentation shall be available on request of the State recipient or EPA. As to each payroll copy received, the subrecipient shall provide written confirmation in a form satisfactory to the State indicating whether or not the project is in compliance with the requirements of 29 CFR 5.5(a)(1) based on the most recent payroll copies for the specified week. The payrolls shall set out accurately and completely all of the information required to be maintained under 29 CFR 5.5(a)(3)(i), except that full social security numbers and home addresses shall not be included on the weekly payrolls. Instead the payrolls shall only need to include an individually identifying number for each employee (e.g., the last four digits of the employee's social security number). The required weekly payroll information may be submitted in any form desired. Optional Form WH-347 is available for this purpose from the Wage and Hour Division Web site at <http://www.dol.gov/esa/whd/forms/wh347instr.htm> or its successor site. The prime contractor is responsible for the submission of copies of payrolls by all subcontractors. Contractors and subcontractors shall maintain the full social security number and current address of each covered worker, and shall provide them upon request to the subrecipient(s) for transmission to the State or EPA if requested by EPA, the State, the contractor, or the Wage and Hour Division of the Department of Labor for purposes of an investigation or audit of compliance with prevailing wage requirements. It is not a violation of this section for a prime contractor to require a subcontractor to provide addresses and social security numbers to the prime contractor for its own records, without weekly submission to the subrecipient(s).

(B) Each payroll submitted shall be accompanied by a "Statement of Compliance," signed by the contractor or subcontractor or his or her agent who pays or supervises the payment of the persons employed under the contract and shall certify the following:

(1) That the payroll for the payroll period contains the information required to be provided under § 5.5 (a)(3)(ii) of Regulations, 29 CFR part 5, the appropriate information is being maintained under § 5.5 (a)(3)(i) of Regulations, 29 CFR part 5, and that such information is correct and complete;

(2) That each laborer or mechanic (including each helper, apprentice, and trainee) employed on the contract during the payroll period has been paid the full weekly wages earned, without rebate, either directly or indirectly, and that no deductions have been made either directly or

STATE REVOLVING FUND LOAN PROGRAM

indirectly from the full wages earned, other than permissible deductions as set forth in Regulations, 29 CFR part 3;

(3) That each laborer or mechanic has been paid not less than the applicable wage rates and fringe benefits or cash equivalents for the classification of work performed, as specified in the applicable wage determination incorporated into the contract.

(C) The weekly submission of a properly executed certification set forth on the reverse side of Optional Form WH-347 shall satisfy the requirement for submission of the "Statement of Compliance" required by paragraph (a)(3)(ii)(B) of this section.

(D) The falsification of any of the above certifications may subject the contractor or subcontractor to civil or criminal prosecution under section 1001 of title 18 and section 231 of title 31 of the United States Code.

(iii) The contractor or subcontractor shall make the records required under paragraph (a)(3)(i) of this section available for inspection, copying, or transcription by authorized representatives of the State, EPA or the Department of Labor, and shall permit such representatives to interview employees during working hours on the job. If the contractor or subcontractor fails to submit the required records or to make them available, the Federal agency or State may, after written notice to the contractor, sponsor, applicant, or owner, take such action as may be necessary to cause the suspension of any further payment, advance, or guarantee of funds. Furthermore, failure to submit the required records upon request or to make such records available may be grounds for debarment action pursuant to 29 CFR 5.12.

(4) Apprentices and trainees--

(i) Apprentices. Apprentices will be permitted to work at less than the predetermined rate for the work they performed when they are employed pursuant to and individually registered in a bona fide apprenticeship program registered with the U.S. Department of Labor, Employment and Training Administration, Office of Apprenticeship Training, Employer and Labor Services, or with a State Apprenticeship Agency recognized by the Office, or if a person is employed in his or her first 90 days of probationary employment as an apprentice in such an apprenticeship program, who is not individually registered in the program, but who has been certified by the Office of Apprenticeship Training, Employer and Labor Services or a State Apprenticeship Agency (where appropriate) to be eligible for probationary employment as an apprentice. The allowable ratio of apprentices to journeymen on the job site in any craft classification shall not be greater than the ratio permitted to the contractor as to the entire work force under the registered program. Any worker listed on a payroll at an apprentice wage rate, who is not registered or otherwise employed as stated above, shall be paid not less than the applicable wage rate on the wage determination for the classification of work actually performed. In addition, any apprentice performing work on the job site in excess of the ratio permitted under the registered program shall be paid not less than the applicable wage rate on the wage determination for the work actually performed. Where a contractor is performing construction on a project in a locality other than that in which its program is registered, the ratios and wage rates (expressed in percentages of the journeyman's hourly rate) specified in the contractor's or subcontractor's registered program shall be observed. Every apprentice must be paid at not less than the rate specified in the registered program for the apprentice's level of progress, expressed as a percentage of the journeymen hourly rate specified in the applicable wage determination. Apprentices shall be paid fringe benefits in accordance with the provisions of the apprenticeship program. If the apprenticeship program does not specify fringe benefits, apprentices must be paid the full amount of fringe benefits listed on the wage determination for the applicable classification. If the Administrator determines that a different practice prevails for the applicable apprentice classification, fringes shall be paid in accordance with that determination. In the event the Office of Apprenticeship Training, Employer and Labor Services, or a State Apprenticeship Agency

STATE REVOLVING FUND LOAN PROGRAM

recognized by the Office, withdraws approval of an apprenticeship program, the contractor will no longer be permitted to utilize apprentices at less than the applicable predetermined rate for the work performed until an acceptable program is approved.

(ii) Trainees. Except as provided in 29 CFR 5.16, trainees will not be permitted to work at less than the predetermined rate for the work performed unless they are employed pursuant to and individually registered in a program which has received prior approval, evidenced by formal certification by the U.S. Department of Labor, Employment and Training Administration. The ratio of trainees to journeymen on the job site shall not be greater than permitted under the plan approved by the Employment and Training Administration. Every trainee must be paid at not less than the rate specified in the approved program for the trainee's level of progress, expressed as a percentage of the journeyman hourly rate specified in the applicable wage determination. Trainees shall be paid fringe benefits in accordance with the provisions of the trainee program. If the trainee program does not mention fringe benefits, trainees shall be paid the full amount of fringe benefits listed on the wage determination unless the Administrator of the Wage and Hour Division determines that there is an apprenticeship program associated with the corresponding journeyman wage rate on the wage determination which provides for less than full fringe benefits for apprentices. Any employee listed on the payroll at a trainee rate who is not registered and participating in a training plan approved by the Employment and Training Administration shall be paid not less than the applicable wage rate on the wage determination for the classification of work actually performed. In addition, any trainee performing work on the job site in excess of the ratio permitted under the registered program shall be paid not less than the applicable wage rate on the wage determination for the work actually performed. In the event the Employment and Training Administration withdraws approval of a training program, the contractor will no longer be permitted to utilize trainees at less than the applicable predetermined rate for the work performed until an acceptable program is approved.

(iii) Equal employment opportunity. The utilization of apprentices, trainees and journeymen under this part shall be in conformity with the equal employment opportunity requirements of Executive Order 11246, as amended, and 29 CFR part 30.

(5) Compliance with Copeland Act requirements. The contractor shall comply with the requirements of 29 CFR part 3, which are incorporated by reference in this contract.

(6) Subcontracts. The contractor or subcontractor shall insert in any subcontracts the clauses contained in 29 CFR 5.5(a)(1) through (10) and such other clauses as the EPA determines may be appropriate, and also a clause requiring the subcontractors to include these clauses in any lower tier subcontracts. The prime contractor shall be responsible for

the compliance by any subcontractor or lower tier subcontractor with all the contract clauses in 29 CFR 5.5.

(7) Contract termination; debarment. A breach of the contract clauses in 29 CFR 5.5 may be grounds for termination of the contract, and for debarment as a contractor and a subcontractor as provided in 29 CFR 5.12.

(8) Compliance with Davis-Bacon and Related Act requirements. All rulings and interpretations of the Davis-Bacon and Related Acts contained in 29 CFR parts 1, 3, and 5 are herein incorporated by reference in this contract.

(9) Disputes concerning labor standards. Disputes arising out of the labor standards provisions of this contract shall not be subject to the general disputes clause of this contract. Such disputes shall be resolved in accordance with the procedures of the Department of Labor set forth in 29 CFR parts 5, 6, and 7. Disputes within the meaning of this clause include disputes between the contractor (or any of its subcontractors) and Subrecipient(s), State, EPA, the U.S. Department of Labor, or the employees or their representatives.

STATE REVOLVING FUND LOAN PROGRAM

(10) Certification of eligibility.

(i) By entering into this contract, the contractor certifies that neither it (nor he or she) nor any person or firm who has an interest in the contractor's firm is a person or firm ineligible to be awarded Government contracts by virtue of section 3(a) of the Davis-Bacon Act or 29 CFR 5.12(a)(1).

(ii) No part of this contract shall be subcontracted to any person or firm ineligible for award of a Government contract by virtue of section 3(a) of the Davis-Bacon Act or 29 CFR 5.12(a)(1).

(iii) The penalty for making false statements is prescribed in the U.S. Criminal Code, 18 U.S.C. 1001.

4. Contract Provision for Contracts in Excess of \$100,000.

(a) Contract Work Hours and Safety Standards Act. The subrecipient shall insert the following clauses set forth in paragraphs (a)(1), (2), (3), and (4) of this section in full in any contract in an amount in excess of \$100,000 and subject to the overtime provisions of the Contract Work Hours and Safety Standards Act. These clauses shall be inserted in addition to the clauses required by Item 3, above or 29 CFR 4.6. As used in this paragraph, the terms laborers and mechanics include watchmen and guards.

(1) Overtime requirements. No contractor or subcontractor contracting for any part of the contract work which may require or involve the employment of laborers or mechanics shall require or permit any such laborer or mechanic in any workweek in which he or she is employed on such work to work in excess of forty hours in such workweek unless such

laborer or mechanic receives compensation at a rate not less than one and one-half times the basic rate of pay for all hours worked in excess of forty hours in such workweek.

(2) Violation; liability for unpaid wages; liquidated damages. In the event of any violation of the clause set forth in paragraph (a)(1) of this section the contractor and any subcontractor responsible therefore shall be liable for the unpaid wages. In addition, such contractor and subcontractor shall be liable to the United States (in the case of work done under contract for the District of Columbia or a territory, to such District or to such territory), for liquidated damages. Such liquidated damages shall be computed with respect to each individual laborer or mechanic, including watchmen and guards, employed in violation of the clause set forth in paragraph (a)(1) of this section, in the sum of \$10 for each calendar day on which such individual was required or permitted to work in excess of the standard workweek of forty hours without payment of the overtime wages required by the clause set forth in paragraph (a)(1) of this section.

(3) Withholding for unpaid wages and liquidated damages. The subrecipient, upon written request of the EPA Award Official or an authorized representative of the Department of Labor, shall withhold or cause to be withheld, from any moneys payable on account of work performed by the contractor or subcontractor under any such contract or any other Federal contract with the same prime contractor, or any other federally-assisted contract subject to the Contract Work Hours and Safety Standards Act, which is held by the same prime contractor, such sums as may be determined to be necessary to satisfy any liabilities of such contractor or subcontractor for unpaid wages and liquidated damages as provided in the clause set forth in paragraph (b)(2) of this section.

(4) Subcontracts. The contractor or subcontractor shall insert in any subcontracts the clauses set forth in paragraph (a)(1) through (4) of this section and also a clause requiring the subcontractors to include these clauses in any lower tier subcontracts. The prime contractor shall be responsible for compliance by any subcontractor or lower tier subcontractor with the clauses set forth in paragraphs (a)(1) through (4) of this section.

STATE REVOLVING FUND LOAN PROGRAM

(b) In addition to the clauses contained in Item 3, above, in any contract subject only to the Contract Work Hours and Safety Standards Act and not to any of the other statutes cited in 29 CFR 5.1, the Subrecipient shall insert a clause requiring that the contractor or subcontractor shall maintain payrolls and basic payroll records during the course of the work and shall preserve them for a period of three years from the completion of the contract for all laborers and mechanics, including guards and watchmen, working on the contract. Such records shall contain the name and address of each such employee, social security number, correct classifications, hourly rates of wages paid, daily and weekly number of hours worked, deductions made, and actual wages paid. Further, the Subrecipient shall insert in any such contract a clause providing that the records to be maintained under this paragraph shall be made available by the contractor or subcontractor for inspection, copying, or transcription by authorized representatives of the (write the name of agency) and the Department of Labor, and the contractor or subcontractor will permit such representatives to interview employees during working hours on the job.

STATE REVOLVING FUND LOAN PROGRAM

Loan Recipient's Requirements

Davis-Bacon Act Wage Determination

The Loan Recipient must ensure the bidder is in compliance with the Davis-Bacon Act as outlined below. Additionally, ten (10) days prior to the scheduled bid opening date, the wage rates need to be checked to ensure they have not changed.

The Davis-Bacon Act as amended, requires that each contract over \$2,000 to which the United States or the District of Columbia is a party for the construction, alteration, or repair of public buildings or public works shall contain a clause setting forth the minimum wages to be paid to various classes of laborers and mechanics employed under the contract. Under the provisions of the Act, contractors or their subcontractors are to pay workers employed directly upon the site of the work no less than the locally prevailing wages and fringe benefits paid on projects of a similar character. The Davis-Bacon Act directs the Secretary of Labor to determine such local prevailing wage rates.

The specifications must incorporate a clause stating that the current Davis-Bacon wage rate is required (with the Davis-Bacon links and information).

The Bid Advertisement **must include** a clause that the **Davis-Bacon wage rates** are a requirement. (Refer to the ADVERTISEMENT FOR BIDS EXAMPLE – DBE, ARRA)

If modifications to the existing **wage rates** occur **ten (10) days** prior to the Bid Opening Date, the Loan Recipient **must** incorporate the proper **wage rates** into the plans and specifications by Addendum. All Bidders **must** be informed that this addendum **must** be incorporated into the plans and specifications that they have received.

However, if these modifications occur **less than ten (10) days** prior to the Bid Opening Date, these modifications **shall be effective unless** the agency **finds** that there is not a reasonable time still available before the Bid Opening to notify bidders of the modifications. (A report of this **finding** shall be inserted in the contract file.)

The **wage determination** (including any additional **classifications** and **wage rates** conformed) **and** a Davis-Bacon poster (WH-1321) **must be posted on the work site at all times** by the contractor and its subcontractors in a prominent and accessible place where it can be easily seen. The WH-1321 poster **may be obtained at no charge** from offices of the Wage and Hour Division.

With each **pay estimate** submitted, the contractors **must** certify that workers have been paid the current prevailing wage rates for each classification according to the Davis-Bacon wage rate schedule currently in effect for this project.

The loan recipients **must keep a file** in which all documentation **must be filed** for the current classifications and wage rates (under the Davis-Bacon Act) for the construction of their projects. This file must be kept for three (3) years after the project is completed and **will** be subject to audit by the State of Tennessee and the Environmental Protection Agency (EPA).

Wage Determinations

A "wage determination" is the listing of wage rates and fringe benefit rates for each classification of laborers and mechanics which the Administrator of the Wage and Hour Division of the U.S. Department of Labor has determined to be prevailing in a given area for a particular type of construction (e.g., building, heavy, highway, or residential).

STATE REVOLVING FUND LOAN PROGRAM

Extensions of Wage Determinations

When a general wage determination has not been awarded within 90 days after bid opening, the head of the contracting/assisting agency may request an extension of the 90 day period from the Wage and Hour Administrator. When, due to unavoidable circumstances, a project wage determination expires before award but after bid opening, the head of the contracting/assisting agency may request an extension of the expiration date of the project wage determination in the bid specifications instead of issuing a new wage determination.

Extension requests should be supported by a written finding including a brief statement of the factual support, that extension of the expiration date of the determination is necessary and proper in the public interest to prevent injustice or undue hardship or to avoid serious impairment in the conduct of Government business.

The Administrator of the Wage and Hour Division of the U.S. Department of Labor will either grant or deny the request for an extension after consideration of all the circumstances, including an examination to determine if the previously issued rates remain prevailing. If a request for the extension of a project wage determination is denied, a new wage determination will be issued to replace an expired project wage determination.

Additional information concerning the Davis-Bacon Act and current wage rate determinations can be obtained at the following sites: www.gpo.gov/davisbacon/referencemat.html and www.wdol.gov/.

Wage Rate Requirements Under FY 2010 Appropriations

3. Contract and Subcontract provisions.

(a) The Recipient shall insure that the subrecipient(s) shall insert in full in any contract in excess of \$2,000 which is entered into for the actual construction, alteration and/or repair, including painting and decorating, of a treatment work under the CWSRF or a construction project under the DWSRF financed in whole or in part from Federal funds or in accordance with guarantees of a Federal agency or financed from funds obtained by pledge of any contract of a Federal agency to make a loan, grant or annual contribution (except where a different meaning is expressly indicated), and which is subject to the labor standards provisions of any of the acts listed in § 5.1 or the FY 2010 appropriation, the following clauses:

(1) Minimum wages.

(i) All laborers and mechanics employed or working upon the site of the work will be paid unconditionally and not less often than once a week, and without subsequent deduction or rebate on any account (except such payroll deductions as are permitted by regulations issued by the Secretary of Labor under the Copeland Act (29 CFR part 3)), the full amount of wages and bona fide fringe benefits (or cash equivalents thereof) due at time of payment computed at rates not less than those contained in the wage determination of the Secretary of Labor which is attached hereto and made a part hereof, regardless of any contractual relationship which may be alleged to exist between the contractor and such laborers and mechanics.

Contributions made or costs reasonably anticipated for bona fide fringe benefits under section 1(b)(2) of the Davis-Bacon Act on behalf of laborers or mechanics are considered wages paid to such laborers or mechanics, subject to the provisions of paragraph (a)(1)(iv) of this section; also, regular contributions made or costs incurred for more than a weekly period (but not less often than quarterly) under plans, funds, or programs which cover the particular weekly period, are deemed to be constructively made or incurred during such weekly period. Such laborers and mechanics shall be paid the appropriate wage rate and fringe benefits on the wage determination for the classification of work actually performed, without regard to skill, except as provided in §

STATE REVOLVING FUND LOAN PROGRAM

5.5(a)(4). Laborers or mechanics performing work in more than one classification may be compensated at the rate specified for each classification for the time actually worked therein: Provided, That the employer's payroll records accurately set forth the time spent in each classification in which work is performed. The wage determination (including any additional classification and wage rates conformed under paragraph (a)(1)(ii) of this section) and the Davis-Bacon poster (WH-1321) shall be posted at all times by the contractor and its subcontractors at the site of the work in a prominent and accessible place where it can be easily seen by the workers.

Subrecipients may obtain wage determinations from the U.S. Department of Labor's web site, www.dol.gov.

(ii)(A) The subrecipient(s), on behalf of EPA, shall require that any class of laborers or mechanics, including helpers, which is not listed in the wage determination and which is to be employed under the contract shall be classified in conformance with the wage determination. The State award official shall approve a request for an additional classification and wage rate and fringe benefits therefore only when the following criteria have been met:

(1) The work to be performed by the classification requested is not performed by a classification in the wage determination; and

(2) The classification is utilized in the area by the construction industry; and

(3) The proposed wage rate, including any bona fide fringe benefits, bears a reasonable relationship to the wage rates contained in the wage determination.

(B) If the contractor and the laborers and mechanics to be employed in the classification (if known), or their representatives, and the subrecipient(s) agree on the classification and wage rate (including the amount designated for fringe benefits where appropriate), documentation of the action taken and the request, including the local wage determination shall be sent by the subrecipient (s) to the State award official. The State award official will transmit the request, to the Administrator of the Wage and Hour Division, Employment Standards Administration, U.S. Department of Labor, Washington, DC 20210 and to the EPA DB Regional Coordinator concurrently. The Administrator, or an authorized representative, will approve, modify, or disapprove every additional classification request within 30 days of receipt and so advise the State award official or will notify the State award official within the 30-day period that additional time is necessary.

(C) In the event the contractor, the laborers or mechanics to be employed in the classification or their representatives, and the subrecipient(s) do not agree on the proposed classification and wage rate (including the amount designated for fringe benefits, where appropriate), the award official shall refer the request and the local wage determination, including the views of all interested parties and the recommendation of the State award official, to the Administrator for determination. The request shall be sent to the EPA DB Regional Coordinator concurrently. The Administrator, or an authorized representative, will issue a determination within 30 days of receipt of the request and so advise the contracting officer or will notify the contracting officer within the 30-day period that additional time is necessary.

(D) The wage rate (including fringe benefits where appropriate) determined pursuant to paragraphs (a)(1)(ii)(B) or (C) of this section, shall be paid to all workers performing work in the classification under this contract from the first day on which work is performed in the classification.

(iii) Whenever the minimum wage rate prescribed in the contract for a class of laborers or mechanics includes a fringe benefit which is not expressed as an hourly rate, the

STATE REVOLVING FUND LOAN PROGRAM

contractor shall either pay the benefit as stated in the wage determination or shall pay another bona fide fringe benefit or an hourly cash equivalent thereof.

(iv) If the contractor does not make payments to a trustee or other third person, the contractor may consider as part of the wages of any laborer or mechanic the amount of any costs reasonably anticipated in providing bona fide fringe benefits under a plan or program, Provided, That the Secretary of Labor has found, upon the written request of the contractor, that the applicable standards of the Davis-Bacon Act have been met. The Secretary of Labor may require the contractor to set aside in a separate account assets for the meeting of obligations under the plan or program.

(2) Withholding. The subrecipient(s), shall upon written request of the EPA Award Official or an authorized representative of the Department of Labor, withhold or cause to be withheld from the contractor under this contract or any other Federal contract with the same prime contractor, or any other federally-assisted contract subject to Davis-Bacon prevailing wage requirements, which is held by the same prime contractor, so much of the accrued payments or advances as may be considered necessary to pay laborers and mechanics, including apprentices, trainees, and helpers, employed by the contractor or any subcontractor the full amount of wages required by the contract. In the event of failure to pay any laborer or mechanic, including any apprentice, trainee, or helper, employed or working on the site of the work, all or part of the wages required by the contract, the (Agency) may, after written notice to the contractor, sponsor, applicant, or owner, take such action as may be necessary to cause the suspension of any further payment, advance, or guarantee of funds until such violations have ceased.

(3) Payrolls and basic records.

(i) Payrolls and basic records relating thereto shall be maintained by the contractor during the course of the work and preserved for a period of three years thereafter for all laborers and mechanics working at the site of the work. Such records shall contain the name, address, and social security number of each such worker, his or her correct classification, hourly rates of wages paid (including rates of contributions or costs anticipated for bona fide fringe benefits or cash equivalents thereof of the types described in section 1(b)(2)(B) of the Davis-Bacon Act), daily and weekly number of hours worked, deductions made and actual wages paid. Whenever the Secretary of Labor has found under 29 CFR 5.5(a)(1)(iv) that the wages of any laborer or mechanic include the amount of any costs reasonably anticipated in providing benefits under a plan or program described in section 1(b)(2)(B) of the Davis-Bacon Act, the contractor shall maintain records which show that the commitment to provide such benefits is enforceable, that the plan or program is financially responsible, and that the plan or program has been communicated in writing to the laborers or mechanics affected, and records which show the costs anticipated or the actual cost incurred in providing such benefits. Contractors employing apprentices or trainees under approved programs shall maintain written evidence of the registration of apprenticeship programs and certification of trainee programs, the registration of the apprentices and trainees, and the ratios and wage rates prescribed in the applicable programs.

(ii)(A) The contractor shall submit weekly, for each week in which any contract work is performed, a copy of all payrolls to the subrecipient, that is, the entity that receives the sub-grant or loan from the State capitalization grant recipient. Such documentation shall be available on request of the State recipient or EPA. As to each payroll copy received, the subrecipient shall provide written confirmation in a form satisfactory to the State indicating whether or not the project is in compliance with the requirements of 29 CFR 5.5(a)(1) based on the most recent payroll copies for the specified week. The payrolls shall set out accurately and completely all of the information required to be maintained under 29 CFR 5.5(a)(3)(i), except that full social security numbers and home addresses shall not be included on the weekly payrolls. Instead the payrolls shall only need to include an individually identifying number for each employee (e.g.,

STATE REVOLVING FUND LOAN PROGRAM

the last four digits of the employee's social security number). The required weekly payroll information may be submitted in any form desired. Optional Form WH-347 is available for this purpose from the Wage and Hour Division Web site at <http://www.dol.gov/esa/whd/forms/wh347instr.htm> or its successor site. The prime contractor is responsible for the submission of copies of payrolls by all subcontractors. Contractors and subcontractors shall maintain the full social security number and current address of each covered worker, and shall provide them upon request to the subrecipient(s) for transmission to the State or EPA if requested by EPA, the State, the contractor, or the Wage and Hour Division of the Department of Labor for purposes of an investigation or audit of compliance with prevailing wage requirements. It is not a violation of this section for a prime contractor to require a subcontractor to provide addresses and social security numbers to the prime contractor for its own records, without weekly submission to the subrecipient(s).

(B) Each payroll submitted shall be accompanied by a "Statement of Compliance," signed by the contractor or subcontractor or his or her agent who pays or supervises the payment of the persons employed under the contract and shall certify the following:

(1) That the payroll for the payroll period contains the information required to be provided under § 5.5 (a)(3)(ii) of Regulations, 29 CFR part 5, the appropriate information is being maintained under § 5.5 (a)(3)(i) of Regulations, 29 CFR part 5, and that such information is correct and complete;

(2) That each laborer or mechanic (including each helper, apprentice, and trainee) employed on the contract during the payroll period has been paid the full weekly wages earned, without rebate, either directly or indirectly, and that no deductions have been made either directly or indirectly from the full wages earned, other than permissible deductions as set forth in Regulations, 29 CFR part 3;

(3) That each laborer or mechanic has been paid not less than the applicable wage rates and fringe benefits or cash equivalents for the classification of work performed, as specified in the applicable wage determination incorporated into the contract.

(C) The weekly submission of a properly executed certification set forth on the reverse side of Optional Form WH-347 shall satisfy the requirement for submission of the "Statement of Compliance" required by paragraph (a)(3)(ii)(B) of this section.

(D) The falsification of any of the above certifications may subject the contractor or subcontractor to civil or criminal prosecution under section 1001 of title 18 and section 231 of title 31 of the United States Code.

(iii) The contractor or subcontractor shall make the records required under paragraph (a)(3)(i) of this section available for inspection, copying, or transcription by authorized representatives of the State, EPA or the Department of Labor, and shall permit such representatives to interview employees during working hours on the job. If the contractor or subcontractor fails to submit the required records or to make them available, the Federal agency or State may, after written notice to the contractor, sponsor, applicant, or owner, take such action as may be necessary to cause the suspension of any further payment, advance, or guarantee of funds. Furthermore, failure to submit the required records upon request or to make such records available may be grounds for debarment action pursuant to 29 CFR 5.12.

(4) Apprentices and trainees--

(i) Apprentices. Apprentices will be permitted to work at less than the predetermined rate for the work they performed when they are employed pursuant to and individually registered in a bona fide apprenticeship program registered with the U.S. Department of Labor, Employment and Training Administration, Office of Apprenticeship Training, Employer and Labor Services, or

STATE REVOLVING FUND LOAN PROGRAM

with a State Apprenticeship Agency recognized by the Office, or if a person is employed in his or her first 90 days of probationary employment as an apprentice in such an apprenticeship program, who is not individually registered in the program, but who has been certified by the Office of Apprenticeship Training, Employer and Labor Services or a State Apprenticeship Agency (where appropriate) to be eligible for probationary employment as an apprentice. The allowable ratio of apprentices to journeymen on the job site in any craft classification shall not be greater than the ratio permitted to the contractor as to the entire work force under the registered program. Any worker listed on a payroll at an apprentice wage rate, who is not registered or otherwise employed as stated above, shall be paid not less than the applicable wage rate on the wage determination for the classification of work actually performed. In addition, any apprentice performing work on the job site in excess of the ratio permitted under the registered program shall be paid not less than the applicable wage rate on the wage determination for the work actually performed. Where a contractor is performing construction on a project in a locality other than that in which its program is registered, the ratios and wage rates (expressed in percentages of the journeyman's hourly rate) specified in the contractor's or subcontractor's registered program shall be observed. Every apprentice must be paid at not less than the rate specified in the registered program for the apprentice's level of progress, expressed as a percentage of the journeymen hourly rate specified in the applicable wage determination. Apprentices shall be paid fringe benefits in accordance with the provisions of the apprenticeship program. If the apprenticeship program does not specify fringe benefits, apprentices must be paid the full amount of fringe benefits listed on the wage determination for the applicable classification. If the Administrator determines that a different practice prevails for the applicable apprentice classification, fringes shall be paid in accordance with that determination. In the event the Office of Apprenticeship Training, Employer and Labor Services, or a State Apprenticeship Agency recognized by the Office, withdraws approval of an apprenticeship program, the contractor will no longer be permitted to utilize apprentices at less than the applicable predetermined rate for the work performed until an acceptable program is approved.

(ii) Trainees. Except as provided in 29 CFR 5.16, trainees will not be permitted to work at less than the predetermined rate for the work performed unless they are employed pursuant to and individually registered in a program which has received prior approval, evidenced by formal certification by the U.S. Department of Labor, Employment and Training Administration. The ratio of trainees to journeymen on the job site shall not be greater than permitted under the plan approved by the Employment and Training Administration. Every trainee must be paid at not less than the rate specified in the approved program for the trainee's level of progress, expressed as a percentage of the journeyman hourly rate specified in the applicable wage determination. Trainees shall be paid fringe benefits in accordance with the provisions of the trainee program. If the trainee program does not mention fringe benefits, trainees shall be paid the full amount of fringe benefits listed on the wage determination unless the Administrator of the Wage and Hour Division determines that there is an apprenticeship program associated with the corresponding journeyman wage rate on the wage determination which provides for less than full fringe benefits for apprentices. Any employee listed on the payroll at a trainee rate who is not registered and participating in a training plan approved by the Employment and Training Administration shall be paid not less than the applicable wage rate on the wage determination for the classification of work actually performed. In addition, any trainee performing work on the job site in excess of the ratio permitted under the registered program shall be paid not less than the applicable wage rate on the wage determination for the work actually performed. In the event the Employment and Training Administration withdraws approval of a training program, the contractor will no longer be permitted to utilize trainees at less than the applicable predetermined rate for the work performed until an acceptable program is approved.

STATE REVOLVING FUND LOAN PROGRAM

(iii) Equal employment opportunity. The utilization of apprentices, trainees and journeymen under this part shall be in conformity with the equal employment opportunity requirements of Executive Order 11246, as amended, and 29 CFR part 30.

(5) Compliance with Copeland Act requirements. The contractor shall comply with the requirements of 29 CFR part 3, which are incorporated by reference in this contract.

(6) Subcontracts. The contractor or subcontractor shall insert in any subcontracts the clauses contained in 29 CFR 5.5(a)(1) through (10) and such other clauses as the EPA determines may be appropriate, and also a clause requiring the subcontractors to include these clauses in any lower tier subcontracts. The prime contractor shall be responsible for the compliance by any subcontractor or lower tier subcontractor with all the contract clauses in 29 CFR 5.5.

(7) Contract termination; debarment. A breach of the contract clauses in 29 CFR 5.5 may be grounds for termination of the contract, and for debarment as a contractor and a subcontractor as provided in 29 CFR 5.12.

(8) Compliance with Davis-Bacon and Related Act requirements. All rulings and interpretations of the Davis-Bacon and Related Acts contained in 29 CFR parts 1, 3, and 5 are herein incorporated by reference in this contract.

(9) Disputes concerning labor standards. Disputes arising out of the labor standards provisions of this contract shall not be subject to the general disputes clause of this contract. Such disputes shall be resolved in accordance with the procedures of the Department of Labor set forth in 29 CFR parts 5, 6, and 7. Disputes within the meaning of this clause include disputes between the contractor (or any of its subcontractors) and Subrecipient(s), State, EPA, the U.S. Department of Labor, or the employees or their representatives.

(10) Certification of eligibility.

(i) By entering into this contract, the contractor certifies that neither it (nor he or she) nor any person or firm who has an interest in the contractor's firm is a person or firm ineligible to be awarded Government contracts by virtue of section 3(a) of the Davis-Bacon Act or 29 CFR 5.12(a)(1).

(ii) No part of this contract shall be subcontracted to any person or firm ineligible for award of a Government contract by virtue of section 3(a) of the Davis-Bacon Act or 29 CFR 5.12(a)(1).

(iii) The penalty for making false statements is prescribed in the U.S. Criminal Code, 18 U.S.C. 1001.

4. Contract Provision for Contracts in Excess of \$100,000.

(a) Contract Work Hours and Safety Standards Act. The subrecipient shall insert the following clauses set forth in paragraphs (a)(1), (2), (3), and (4) of this section in full in any contract in an amount in excess of \$100,000 and subject to the overtime provisions of the Contract Work Hours and Safety Standards Act. These clauses shall be inserted in addition to the clauses required by Item 3, above or 29 CFR 4.6. As used in this paragraph, the terms laborers and mechanics include watchmen and guards.

(1) Overtime requirements. No contractor or subcontractor contracting for any part of the contract work which may require or involve the employment of laborers or mechanics shall require or permit any such laborer or mechanic in any workweek in which he or she is employed on such work to work in excess of forty hours in such workweek unless such

laborer or mechanic receives compensation at a rate not less than one and one-half times the basic rate of pay for all hours worked in excess of forty hours in such workweek.

STATE REVOLVING FUND LOAN PROGRAM

(2) Violation; liability for unpaid wages; liquidated damages. In the event of any violation of the clause set forth in paragraph (a)(1) of this section the contractor and any subcontractor responsible therefore shall be liable for the unpaid wages. In addition, such contractor and subcontractor shall be liable to the United States (in the case of work done under contract for the District of Columbia or a territory, to such District or to such territory), for liquidated damages. Such liquidated damages shall be computed with respect to each individual laborer or mechanic, including watchmen and guards, employed in violation of the clause set forth in paragraph (a)(1) of this section, in the sum of \$10 for each calendar day on which such individual was required or permitted to work in excess of the standard workweek of forty hours without payment of the overtime wages required by the clause set forth in paragraph (a)(1) of this section.

(3) Withholding for unpaid wages and liquidated damages. The subrecipient, upon written request of the EPA Award Official or an authorized representative of the Department of Labor, shall withhold or cause to be withheld, from any moneys payable on account of work performed by the contractor or subcontractor under any such contract or any other Federal contract with the same prime contractor, or any other federally-assisted contract subject to the Contract Work Hours and Safety Standards Act, which is held by the same prime contractor, such sums as may be determined to be necessary to satisfy any liabilities of such contractor or subcontractor for unpaid wages and liquidated damages as provided in the clause set forth in paragraph (b)(2) of this section.

(4) Subcontracts. The contractor or subcontractor shall insert in any subcontracts the clauses set forth in paragraph (a)(1) through (4) of this section and also a clause requiring the subcontractors to include these clauses in any lower tier subcontracts. The prime contractor shall be responsible for compliance by any subcontractor or lower tier subcontractor with the clauses set forth in paragraphs (a)(1) through (4) of this section.

(b) In addition to the clauses contained in Item 3, above, in any contract subject only to the Contract Work Hours and Safety Standards Act and not to any of the other statutes cited in 29 CFR 5.1, the Subrecipient shall insert a clause requiring that the contractor or subcontractor shall maintain payrolls and basic payroll records during the course of the work and shall preserve them for a period of three years from the completion of the contract for all laborers and mechanics, including guards and watchmen, working on the contract. Such records shall contain the name and address of each such employee, social security number, correct classifications, hourly rates of wages paid, daily and weekly number of hours worked, deductions made, and actual wages paid. Further, the Subrecipient shall insert in any such contract a clause providing that the records to be maintained under this paragraph shall be made available by the contractor or subcontractor for inspection, copying, or transcription by authorized representatives of the (write the name of agency) and the Department of Labor, and the contractor or subcontractor will permit such representatives to interview employees during working hours on the job.

STATE REVOLVING FUND LOAN PROGRAM

Loan Recipient's and Contractor's Guidance

FY2010 and After

Tracking and Reporting

For tracking and reporting purposes, the **Loan Recipient** is responsible for the following:

- Ensuring that the Contractor is in compliance with the Davis Bacon provisions of ARRA
- The loan recipients **must keep a file** in which all documentation **must be stored** for the current classifications and wage rates (under the Davis-Bacon Act) for the construction of their projects. This file must be kept for three (3) years after the project is completed and **will** be subject to audit by the State of Tennessee and the Environmental Protection Agency (EPA).
- Any additional tracking and reporting requirements from EPA

For tracking and reporting purposes, the **Contractor** is responsible for the following:

- Achieving and maintaining compliance with the Davis Bacon provisions of ARRA
- Submitting with each **pay estimate** a certification stating that workers have been paid the current prevailing wage rates for each classification according to the Davis-Bacon wage rate schedule currently in effect for this project
- Any additional tracking and reporting requirements from EPA

Please contact **Dr. Bagher Sami, Administrative Section Manager for the SRF Loan Program**, at 615-532-0501 or bagher.sami@tn.gov to obtain details.

NOTICE

THIS ENTITY IS A RECIPIENT OF **STATE AND FEDERAL FUNDS**. IF YOU HAVE KNOWLEDGE OF ANY ACTIVITY WHICH YOU CONSIDER TO BE ILLEGAL, IMPROPER, OR WASTEFUL, PLEASE CALL THE STATE COMPTROLLER'S TOLL-FREE HOTLINE:

1-800-232-5454





TENNESSEE DEPARTMENT OF ENVIRONMENT AND CONSERVATION

Division of Water Resources

William R. Snodgrass Tennessee Tower, 312 Rosa L. Parks Avenue, 11th Floor, Nashville, Tennessee 37243
1-888-891-8332 (TDEC)

Notice of Intent (NOI) for General NPDES Permit for Stormwater Discharges from Construction Activities (TNR100000)

Form with multiple sections: Site or Project Name, Street Address or Location, Site Activity Description, County(ies), MS4 Jurisdiction, Existing NPDES Tracking Number, Start date, Estimated end date, Latitude, Longitude, Acres Disturbed, Total Acres, Receiving waters, Attach the SWPPP with the NOI, Site Owner/Developer Entity, Site Owner/Developer Signatory, Mailing Address, Phone, Fax, E-mail, Optional Contact, Title or Position, Owner or Developer Certification, Contractor(s) Certification, Other Contractor company name.

OFFICIAL STATE USE ONLY

Table with 4 columns: Received Date, Reviewer, Field Office, Permit Number TNR, Exceptional TN Water, Fee(s), T & E Aquatic Flora and Fauna, Impaired Receiving Stream, Notice of Coverage Date.

Notice of Intent (NOI) for General NPDES Permit for Stormwater Discharges from Construction Activities (TNR10000)

Purpose of this form A completed notice of intent (NOI) must be submitted to obtain coverage under the Tennessee General NPDES Permit for Discharges of Stormwater Associated with Construction Activity (permit). **Requesting coverage under this permit means that an applicant has obtained and examined a copy of this permit, and thereby acknowledges applicant’s claim of ability to be in compliance with permit terms and conditions.** This permit is required for stormwater discharge(s) from construction activities including clearing, grading, filling and excavating (including borrow pits) of one or more acres of land. This form should be submitted at least 30 days prior to the commencement of land disturbing activities, or no later than 48 hours prior to when a new operator assumes operational control over site specifications or commences work at the site.

Permit fee (see table below) must accompany the NOI and is based on total acreage to be disturbed by an entire project, including any associated construction support activities (e.g. equipment staging yards, material storage areas, excavated material disposal areas, borrow or waste sites). There is no fee for sites less than 1 acre.

Acres Disturbed	= or > 150 acres	= or > 50 < 150 acres	= or > 5 < 50 acres	= or > 1 < 5 acres
Fee	\$7,500	\$4,000	\$1,000	\$250

Who must submit the NOI form? Per Section 2 of the permit, all site operators must submit an NOI form. “Operator” for the purpose of this permit and in the context of stormwater associated with construction activity means any person associated with a construction project who meets either or both of the following two criteria: (1) The person has operational or design control over construction plans and specifications, including the ability to make modifications to those plans and specifications. This person is typically the owner or developer of the project or a portion of the project (e.g. subsequent builder), or the person that is the current land owner of the construction site. This person is considered the primary permittee; or (2) The person has day-to-day operational control of those activities at a project which are necessary to ensure compliance with a SWPPP for the site or other permit conditions. This person is typically a contractor or a commercial builder who is hired by the primary permittee, and is considered a secondary permittee.

Owners, developers and all contractors that meet the definition of the operator in subsection 2.2 of the permit shall apply for permit coverage on the same NOI, insofar as possible. After permit coverage has been granted to the primary permittee, any subsequent NOI submittals must include the site’s previously assigned permit tracking number and the project name. The comprehensive site-specific SWPPP shall be prepared in accordance with the requirements of part 3 of the permit and must be submitted with the NOI unless the NOI being submitted is to only add a contractor (secondary permittee) to an existing coverage.

Notice of Coverage The division will review the NOI for completeness and accuracy and prepare a notice of coverage (NOC). Stormwater discharge from the construction site is authorized as of the effective date of the NOC.

Complete the form Type or print clearly, using ink and not markers or pencil. Answer each item or enter “NA,” for not applicable, if a particular item does not fit the circumstances or characteristics of your construction site or activity. If you need additional space, attach a separate piece of paper to the NOI form. **The NOI will be considered incomplete without a permit fee, a map, and the SWPPP.**

Describe and locate the project Use the legal or official name of the construction site. If a construction site lacks street name or route number, give the most accurate geographic information available to describe the location (reference to adjacent highways, roads and structures; e.g. intersection of state highways 70 and 100). Latitude and longitude (expressed in decimal degrees) of the center of the site can be located on USGS quadrangle maps. The quadrangle maps can be obtained at the USGS World Wide Web site: <http://www.usgs.gov/>; latitude and longitude information can be found at numerous other web sites. Attach a copy of a portion of a 7.5 minute quad map, showing location of site, with boundaries at least one mile outside the site boundaries. Provide estimated starting date of clearing activities and completion date of the project, and an estimate of the number of acres of the site on which soil will be disturbed, including borrow areas, fill areas, stockpiles and the total acres. For linear projects, give location at each end of the construction area.

MS4 Jurisdiction: If this construction site is located within a Municipal Separate Storm Sewer System (MS4), please list name of MS4. A current list of MS4s in Tennessee may be found at http://www.tn.gov/environment/wpc/stormh2o/docs/MS4s_Jan2012.pdf

Give name of the receiving waters Trace the route of stormwater runoff from the construction site and determine the name of the river(s), stream(s), creek(s), wetland(s), lake(s) or any other water course(s) into which the stormwater runoff drains. Note that the receiving water course may or may not be located on the construction site. If the first water body receiving construction site runoff is unnamed (“unnamed tributary”), determine the name of the water body that the unnamed tributary enters.

ARAP permit may be required **If your work will disturb or cause alterations of a stream or wetland, you must obtain an appropriate Aquatic Resource Alteration Permit (ARAP).** If you have a question about the ARAP program or permits, contact your local Environmental Field Office (EFO).

Submitting the form and obtaining more information Note that this form must be signed by the company President, Vice-President, or a ranking elected official in the case of a municipality, for details see subpart 2.5. For more information, contact your local EFO at the toll-free number 1-888-891-8332 (TDEC). Submit the completed NOI form (keep a copy for your records) to the appropriate EFO for the county(ies) where the construction activity is located, addressed to **Attention: Stormwater NOI Processing.**

EFO	Street Address	Zip Code	EFO	Street Address	Zip Code
Memphis	8383 Wolf Lake Drive, Bartlett	38133-4119	Cookeville	1221 South Willow Ave.	38506
Jackson	1625 Hollywood Drive	38305-4316	Chattanooga	540 McCallie Avenue STE 550	37402-2013
Nashville	711 R S Gass Boulevard	37243	Knoxville	3711 Middlebrook Pike	37921
Columbia	1421 Hampshire Pike	38401	Johnson City	2305 Silverdale Road	37601



TENNESSEE DEPARTMENT OF ENVIRONMENT AND CONSERVATION (TDEC)

Division of Water Resources

William R. Snodgrass Tennessee Tower, 312 Rosa L. Parks Avenue, 11th Floor, Nashville, Tennessee 37243
1-888-891-TDEC (8332)

Notice of Termination (NOT) for General NPDES Permit for Stormwater Discharges from Construction Activities (CGP)

This form is required to be submitted when requesting termination of coverage from the CGP. The purpose of this form is to notify the TDEC that either all stormwater discharges associated with construction activity from the portion of the identified facility where you, as an operator, have ceased or have been eliminated; or you are no longer an operator at the construction site. Submission of this form shall in no way relieve the permittee of permit obligations required prior to submission of this form. Please submit this form to the local WPC Environmental Field Office (EFO) address (see table below). For more information, contact your local EFO at the toll-free number 1-888-891-8332 (TDEC).

Type or print clearly, using ink.

Site or Project Name:	NPDES Tracking Number: TNR
Street Address or Location:	County(ies):

Name of Permittee Requesting Termination of Coverage:			
Permittee Contact Name:		Title or Position:	
Mailing Address:		City:	State: Zip:
Phone: ()		E-mail:	

Check the reason(s) for termination of permit coverage:

<input type="checkbox"/>	Stormwater discharge associated with construction activity is no longer occurring and the permitted area has a uniform 70% permanent vegetative cover OR has equivalent measures such as rip rap or geotextiles, in areas not covered with impervious surfaces.
<input type="checkbox"/>	You are no longer the operator at the construction site (i.e., termination of site-wide, primary or secondary permittee coverage).

Certification and Signature: (must be signed by president, vice-president or equivalent ranking elected official)

I certify under penalty of law that either: (a) all stormwater discharges associated with construction activity from the portion of the identified facility where I was an operator have ceased or have been eliminated or (b) I am no longer an operator at the construction site. I understand that by submitting this notice of termination, I am no longer authorized to discharge stormwater associated with construction activity under this general permit, and that discharging pollutants in stormwater associated with construction activity to waters of the United States is unlawful under the Clean Water Act where the discharge is not authorized by a NPDES permit. I also understand that the submittal of this notice of termination does not release an operator from liability for any violations of this permit or the Clean Water Act.

For the purposes of this certification, elimination of stormwater discharges associated with construction activity means that all stormwater discharges associated with construction activities from the identified site that are authorized by a NPDES general permit have been eliminated from the portion of the construction site where the operator had control. Specifically, this means that all disturbed soils at the portion of the construction site where the operator had control have been finally stabilized, the temporary erosion and sediment control measures have been removed, and/or subsequent operators have obtained permit coverage for the site or portions of the site where the operator had control.

I certify under penalty of law that this document and all attachments were prepared by me, or under my direction or supervision. The submitted information is to the best of my knowledge and belief, true, accurate, and complete. I am aware that there are significant penalties for submitting false information, including the possibility of fine and imprisonment. As specified in Tennessee Code Annotated Section 39-16-702(a)(4), this declaration is made under penalty of perjury.

Permittee name (print or type):	Signature:	Date:
---------------------------------	------------	-------

EFO	Street Address	Zip Code	EFO	Street Address	Zip Code
Memphis	8383 Wolf Lake Drive, Bartlett, TN	38133	Cookeville	1221 South Willow Ave.	38506
Jackson	1625 Hollywood Drive	38305	Chattanooga	540 McCallie Avenue STE 550	37402
Nashville	711 R S Gass Boulevard	37243	Knoxville	3711 Middlebrook Pike	37921
Columbia	1421 Hampshire Pike	38401	Johnson City	2305 Silverdale Road	37601

CLEAN WATER STATE REVOLVING FUND

IDENTIFICATION SIGN

All plans and specifications for each project approved shall contain provisions for requiring the general contractor to provide identification signs. The signs shall conform to the following basic features:

1. The following diagram shall be used as a design:

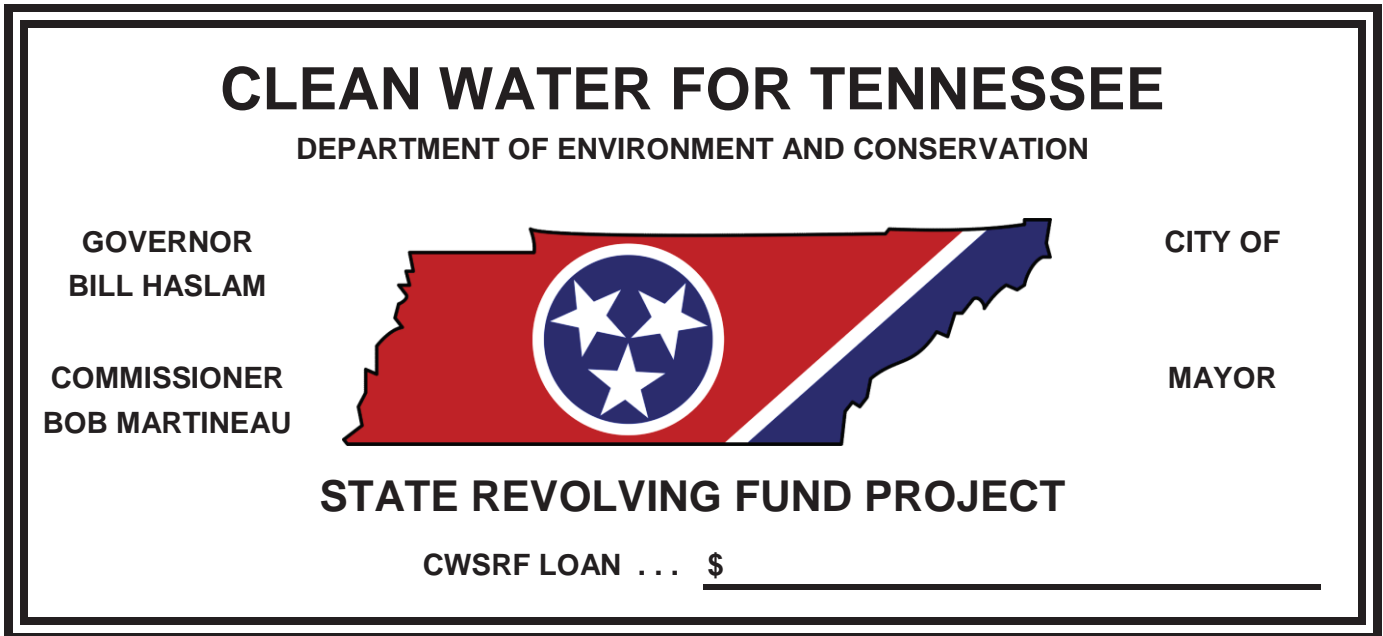

2. The sign shall be a 4'0" X 8'0" sheet of exterior grade plywood and shall be built so as to remain erected during the entire construction phase of the project.
3. The background of both sides shall be white. The lettering shall be black and shall be large enough to take advantage of the full size of the plywood. The stars shall be white set on a blue field and surrounded by a white ring placed inside a state map in red with a stripe of white and blue on the right side. The sign shall be bordered by a one-inch blue stripe.

Revised: JANUARY 20, 2011

STATE REVOLVING FUND LOAN PROGRAM
BID PACKAGE SUBMITTAL REQUIREMENTS

PRIOR TO FINAL CONTRACT AWARD by the State Revolving Fund (SRF) Loan Program, the Loan Recipient must prepare and submit a completed Bid Package to the SRF Loan Program for review and **written approval**. An **Authority-to-Award (ATA)** letter from the SRF Loan Program must be obtained prior to the final contract award and the initiation of construction activities.

A completed Bid Package submittal consists of the following:

1. A copy of the **Advertisement for Bids** appearing in a local or major regional newspaper or the Dodge Report (40 CFR 31.36 (d)(2)(ii)(A)). *The project must be advertised for a minimum of 14 days prior to the bid opening.*
2. An original copy of either the **Award Resolution or the minutes** from the meeting of the governing body (or a certified copy of either) that tentatively awards the contract(s) to the lowest, responsible, responsive bidder(s)
3. A **certified bid tabulation** stamped and signed by the consulting engineer reviewing the bids
4. A copy of the **signed Bid Proposal** of the apparent successful bidder
5. **Equal Employment Opportunity (EEO) documentation** signed by the apparent successful bidder
6. **Bid Bond with Power of Attorney** (40 CFR 31.36(h))
7. Signed and dated U.S. EPA (or other agency) **Contractor Debarment Form**, such as the U.S. Environmental Protection Agency Certification Regarding Debarment, Suspension and Other Responsibility Matters
8. An original, notarized certification of publication (**Publisher's Affidavit**) signed by the editor of the newspaper
9. Copies of a minimum of 10 **certified letters** and "**Return Receipt Requested**" forms sent to potential **Disadvantaged Business Enterprises (DBE)** subcontractors, supplies vendors, service providers, and/or equipment vendors
10. A copy of the current **Davis-Bacon** wage rates used on this project (Davis-Bacon Act)
11. A completed **Loan Recipient's Certification and Summary** of DBE Participation on SRF Projects (40 CFR 31.36 (e)(2)(i through vi))
12. If no **DBE** participation was obtained, a "**Good Faith Effort**" letter (See Good Faith Effort Steps at 40 CFR 31.36 (e)(2)(i through vi))
13. Reference documents:
 - **Loan Recipient's Requirements** for Solicitation and Documentation of **DBE** Participation on SRF Projects
 - **Bidder's Requirements** for Solicitation and Documentation of **DBE** Participation on SRF Projects
 - **Loan Recipient's Certification and Summary** of **DBE** Participation on SRF Loan-Funded Projects
 - **Guidance Document** for **DBE** Requirements for SRF loans
14. If applicable, documentation of the justification for not awarding the contract to the lowest bidder if the award is to be made to a bidder other than the low bidder. The justification must indicate why the low bidder is not responsive or responsible and include documentation of any negotiations leading to the determination.
15. Resume of the resident inspector(s)
16. Documentation of the extension of the bid proposal and bid bond expiration dates, if necessary

If the lowest bid received exceeds the amount budgeted for construction in the SRF-approved SRF Loan Budget, the loan recipient must choose only from the following options:

- **Re-allocate** SRF funds through a budget revision. A revised Budget/Re-budget Form must be submitted to the SRF for review and approval if the re-budgeting option is chosen.
- **Provide** additional funds needed to pay the contract from **local funds** or funding source(s) other than the SRF loan
- **Apply** for an **SRF loan increase**. Application for a loan increase will require re-evaluation of the loan recipient's user rates to determine if the anticipated revenues will be sufficient to repay the requested loan increase and fund the additional depreciation. **Principal forgiveness does not apply to loan increases.**
- **Reject** all bids and **re-bid the project**

Please contact Dr. Bagher Sami by telephone at (615) 532-0501 or by e-mail at bagher.sami@tn.gov if you have any questions concerning the contents of the Bid Package submittal for State Revolving Fund projects.

City Letter Head

Dr. Bagher Sami,
Administrative and Financial Section Manager
State Revolving Fund Loan Program
William R. Snodgrass - Tennessee Tower
312 Rosa L. Parks Avenue, 12th Floor
Nashville, Tennessee 37243-1102

RE: Property, Easements, Rights-of-Way Certification
City/County/UD/Authority (xxxx County or xxx and xxxx Counties), Tennessee
Loan No. SRF CWA CGA DWF DWA DGA 200x-xxx
Loan Description: xxxxxxxxxx
Contract No. / Name 1 of 2—Contract Description
Contract No. / Name 2 of 2—Contract Description

Dear Dr. Sami:

This letter is to certify that all property, easements, and rights-of-way necessary to construct the projects included in the above-referenced contract are owned (or in the case of right-of-way permitted for the use) by the City/County/UD/Authority. And/or The plant improvements are to be constructed on the same site as our existing facility. Based upon this, no "Site Certificate" is required.

Sincerely,

Authorized Representative, Title

SITE CERTIFICATION

I certify that the applicant, the City of ???, ??? County, the ??? Utility District, the ??? Water/Wastewater/Energy Authority has acquired or has entered into condemnation proceedings for all real property including easements and rights-of-way that are or will be required for the construction (erection, extension, modification, addition), operation, and maintenance of the entire wastewater treatment works funded under loan number SRF/CWA/CGA/DWF/DWA/DGA 200?-???

I certify that any deeds or documents required to be recorded in order to protect the title of the owner and the interest of the City of ???, ??? County, the ??? Utility District, the ??? Water/Wastewater/Energy Authority have been duly recorded and filed for record wherever necessary.

I further certify that real property including easements required for the entire wastewater treatment works project was acquired in accordance with the requirements of the Uniform Relocation Assistance and Real Property Acquisition Policies Act of 1970 and EPA's regulation 40 CFR Part 4.

Dated this _____ day of _____, 20____.

Applicants' Authorized Representative

Title (Mayor, City Manager, Commissioner, etc.)

Attorney (Typed and Signed)

00672.7 Bid Bond

Know all men by these presents, that we, the undersigned, _____ as

Principal, and _____ as surety,

Hereby held and firmly bound unto _____ as Owner on the sum of _____ for the payment of which, well and truly to be made, We hereby jointly and severally bind ourselves, our heirs, executors, administrators, successors and assigns.

Signed this _____ day of _____, 2017

This condition of the above obligation is such that whereas the principal has submitted to the Purchaser a certain bid, attached hereto and hereby made a part of hereof to enter into a contract in writing for the construction of:

SARP10 Program 194677.71.0397 Wolf River Interceptor Rehab

Now therefore,

- A) If said bid shall be rejected, or in the alternative,
- B) If said bid shall be accepted and the principal shall execute and deliver a contract in the form of contract attached hereto (properly completed in accordance with said bid), required insurance certificates, and shall furnish a Bond for the payment of all persons performing labor or furnishing materials in connection therewith, and shall in all other respects perform the agreement created by the acceptance of said Bond,

Then this obligation shall be void, otherwise the same shall remain in force and effect; it being expressly understood and agreed that the liability of the surety for any and all claims hereunder shall, in no event, exceed the amount of this obligation as herein stated.

The surety, for value received, hereby stipulates and agrees that the obligations of said surety and its bond shall be in no way impaired or affected by any extension of the time within which the Purchaser may accept such bid; and said surety does hereby waive notice of any such extension.

In witness whereof, the principal and the surety hereunto set their hands and seals, and such of them as are corporations have caused their corporate seals to be hereto affixed and these presents to be signed by their proper officers, the day and year set forth above.

CONTRACTOR

SURETY

Contractor's Company Name

Surety: _____
Name

Signature (principal)

By: _____
Attorney in Fact - Signature

Printed or Typed Name and Title

Printed or Typed Name and Title



00672.8 Schedule Impact Due to Weather

Program Manager will determine Contractor’s entitlement to an extension of the Contract Time as a result of weather delays, based on the data included in Tables 1 and 2. Extensions of time will be granted at the discretion of the Program Manager for circumstances not covered by the flow chart.

The following rules apply to any analysis for weather related delays to this Project. Weather delay days may be awarded if the first two rules are met. Additional days may be awarded if conditions in Rule 3 are met for unusually heavy precipitation independent of Rules 1 and 2.

Rule 1: The average monthly precipitation amount must have been exceeded.

If the total amount of actual precipitation in a month exceeds the average for that month shown in Table 1, the first test has been met. Go to rule number 2. (Precipitation is defined as the quantity of water deposited by rain, hail, sleet, or snow.)

Rule 2: The number of days in a month with actual precipitation greater than the threshold amount shown in Table 2 has been exceeded.

The number of days with actual precipitation greater than the threshold amounts shown in Table 2 are eligible for award as weather delays days. Additional days may be awarded for unusually heavy precipitation independent of meeting the rules above.

Rule 3: Unusually heavy precipitation has occurred.

Precipitation greater than one inch in a single day may be justification for an additional day time extension for each precipitation day. This rule may be applied singly but not in addition with any other rule.

**National Weather Service Data for
Memphis International Airport – Years 2006-2015**

Table 1

Average Precipitation by Month (In Inches)											
Jan.	Feb.	Mar.	Apr.	May	June	July	Aug.	Sept.	Oct.	Nov.	Dec.
4.10	3.51	5.19	5.45	6.11	3.61	3.92	3.06	3.38	3.75	4.29	5.16

Table 2

Average Number of Days with Precipitation Greater than 0.25 Inches											
Jan.	Feb.	Mar.	Apr.	May	June	July	Aug.	Sept.	Oct.	Nov.	Dec.
5	4	5	5	5	3	4	3	3	4	4	5

Any weather-related extension of Contract time shall be non-compensable. Efficiencies gained as a result of favorable weather within a calendar month, where the number of days of normally anticipated weather days is less than expected, shall contribute to the project float and shall not affect the Contract Times. Application for a weather related extension of time shall be submitted to the Program Manager, and shall state the extension requested and be supported by the relevant weather data.



00672.9 Code of Conduct

CODE OF CONDUCT FOR GLOBAL BUSINESS RELATIONSHIPS

Black & Veatch Corporation and its subsidiary companies (collectively hereinafter, the "Company") is a global company that conducts business in many countries through subsidiaries, branches, joint ventures, and other business arrangements.

As a responsible corporate citizen, the Company requires that all of its business operations observe certain basic standards of conduct. Also, as a company subject to the laws of the United States, the Company must ensure that its business relationships outside the United States will comply with the requirements of certain U.S. laws that impose on the Company standards of conduct for its business throughout the world.

For all business relationships, it is the policy of the Company that the following standards of conduct and legal requirements shall be observed in every aspect of transactions with the Company:

- 1) Applicable law must be complied with in the conduct of such relationships. If there is a conflict between applicable local law and applicable U.S. law, the guidance of the Company's Law Department will be sought in order to resolve such a conflict. However, the U.S. laws referred to in Paragraphs 4, 5, and 6 below must be complied with without exception.
- 2) The Company, customers, employees, suppliers, and other persons, organizations, and governments will be dealt with in a fair manner with honesty and integrity, observing high standards of personal and business ethics.
- 3) Business books and records will be maintained in a proper, responsible, and honest manner, which will allow the Company to comply with the laws applicable to it.
- 4) All applicable anti-bribery legislation must be complied with, including without limitation, (i) the domestic laws of the country in which operations take place, (ii) the U.S. Foreign Corrupt Practices Act ("FCPA"), (iii) the United Kingdom Bribery Act ("UKBA"), (iv) the national implementing legislation of any relevant jurisdictions under the Organization for Economic Co-operation and Development ("OECD") Anti-Bribery Convention (Convention on Combating Bribery of Foreign Public Officials in International Business Transactions), and (v) any other applicable anti-bribery legislation.
- 5) The laws of the United States regarding boycotts must be complied with.
- 6) The laws of the United States and any other applicable jurisdictions regarding trade sanctions and export administration and control must be complied with for any information or material supplied by the Company.
- 7) Confidential or proprietary information will not be disclosed at any time to persons outside the business relationship without proper authorization.
- 8) Applicable antitrust and competition laws will be complied with.

00770 – Loss Control Manual

The Loss Control Manual is available for viewing on the SARP10 website:

<http://www.sarp10.com/facts/>

Contact Riley Thompson, Safety Manager for additional information:

ThompsonLR@overlandcontracting.com

(901) 495-2649



Technical Specifications (61 pages)

CITY OF MEMPHIS – STANDARD CONSTRUCTION SPECIFICATIONS

SECTION 00001 – MANHOLE GPS & MACP INSPECTION

Modified by SARP10

PART 1 – SCOPE

- 1.01 This Work shall consist of locating sanitary sewer system facilities, gathering sub-meter grade GPS coordinates of manhole (including lamphole) covers, Manhole Assessment Certification Program (MACP) protocol Level 1 and Level 2 manhole inspections using the National Association of Sewer Service Companies (NASSCO) MACP Version 6.0.1 protocols, associated photographs, camera inspection of manholes and the associated pipe connections, and documentation of manholes not found, not on grade and/or not showing. The work shall also consist of completing an internal 3D manhole scan for each manhole with a depth greater than 25 feet or associated with large-diameter sanitary sewer interceptors (36-inch diameter and larger). Manholes to be located, documented and inspected are in both improved streets, arterial and primary roads, backyards and unimproved easements. Once new manhole coordinates are obtained, the updated source GIS map data shall be delivered to Program Manager in order to reflect the actual sewer system network.

The Work covered by this section includes furnishing all labor, competent MACP certified technicians/crew leads, equipment, tools, accessories, and materials required to GPS, perform MACP Level 1 and Level 2 inspections, conduct 3D scan camera inspections where applicable and document the specified manholes.

- 1.02 Sub-meter GPS coordinates, updated GIS map data, Levels 1 and 2 MACP data and records, and camera inspection photos and 3D scan of the manholes shall be delivered to the Program Manager on clearly labeled external hard drive(s) which will become property of the Program Manager. Inspection data for any one asset shall not be delivered on multiple drives. MACP data files shall be formatted to facilitate upload into a MACP Exchange Database or internet upload to an FTP site as approved by the Program Manager.
- 1.03 Selected Subcontractor(s) will be provided two Geo-databases; one will have supporting records (aerial photo overlays, outfall and block maps and as-builts, as available), and a maiden database which will include the asset ID for each manhole.
- 1.04 Grind or cut any protruding objects (steps) on the surface of the shaft that may cause obstructions to contractor's equipment using appropriate equipment for the atmosphere (i.e. Hydraulic Shears).

PART 2 - MATERIALS AND EQUIPMENT

2.01 MATERIALS

A. Submittals

1. Unless otherwise specified, all sample submittals shall be delivered to the Program Manager within two weeks of the NTP.
2. A Traffic Control Plan shall be submitted to the Program Manager, including the following items:
 - a. Outline of permit acquisition procedure for lane closures.
 - b. Methods for proper signing and barricades, which comply with local requirements and the City.
 - c. Major streets (e.g. Shelby County Principal Arterial & Minor Arterial) requiring a City approved permit if taking a lane for mobile operations, secured through

CITY OF MEMPHIS – STANDARD CONSTRUCTION SPECIFICATIONS

SECTION 00001 – MANHOLE GPS & MACP INSPECTION

Modified by SARP10

Traffic Control Plan submittal to the City and signed by a TN P.E. The City requires a two-week lead time for permit processing.

- i. The Subcontractor will be required to deliver a sample primary/arterial road Traffic Control Plan for review by the City.
 - ii. If the City determines that the nature of the work operation or the type of road in which the Subcontractor is working requires a permit, the Subcontractor will be required to modify the sample Traffic Control Plan to obtain a permit from the City.
 - d. For everywhere else where a permit is not required, the Subcontractor shall develop, provide, and implement a Traffic Control Plan for all mobile operations in accordance with standard MUTCD specifications.
 - e. The Subcontractor is also responsible for acquiring all necessary disposal and/or landfill site permits required to perform this work.
 - f. Railroad Rights of Way: The Subcontractor shall notify the Program Manager when work or access to manholes and sanitary sewers lie within the 25 feet railroad easement, as measured by 25 feet outside the nearest rail of the tracks. To access sewer facilities within the 25 feet of the railroad right of way, the Subcontractor shall contact 48 hours in advance the Program Manager, who will alert the City's Zone Construction Inspector to coordinate individual railroad direction and guidance.
3. Permit required confined space entry plans in compliance with the Loss Control Manual.
 4. GPS calibration standards, including frequency, are to be followed in the field; specify which available base stations will be used for the work.
 5. Sample of sub-meter GPS coordinates delivered in electronic and pdf format.
 6. Copies of NASSCO certifications for all field staff conducting MACP Levels 1 and 2 inspections.
 7. Sample of MACP Level 1 and Level 2 documentation logs (with photo documentation comments and photos properly referenced) in MACP formats, in both electronic and pdf format.
 8. Equipment list, including GPS and 3D camera manufacturer and model equipment to be used.
 9. Sample of the GPS coordinate delivery in an ESRI ArcPAD .axf file format.
 10. Sample of the digital inspection data delivery in MS ACCESS database format.
 11. Sample of 3D manhole inspection and all software necessary to view inspections.

2.02 EQUIPMENT

All equipment used for the gathering of GPS coordinates, collection of condition assessment information, and digital 3D camera inspection of manholes shall be specifically designed and manufactured for the purpose intended under this Contract. The software and hardware for the electronic capture of the inspection defect observations must be consistent with NASSCO's MACP Level 1 and Level 2 requirements for the collection of data. ESRI ArcPad 10.1 is required for GPS data collection and GIS map updates for manhole / lamphole facility locations. Export of the electronic inspection data to an MACP format Microsoft ACCESS database for analysis is required.

The Subcontractor shall submit an equipment list to the Program Manager for approval before the commencement of the Work and shall certify that back-up equipment is available and can be delivered to the worksite in 72 hours.

A. GPS Equipment

CITY OF MEMPHIS – STANDARD CONSTRUCTION SPECIFICATIONS

SECTION 00001 – MANHOLE GPS & MACP INSPECTION

Modified by SARP10

1. GPS Equipment shall be sub-meter grade, Trimble Pro Series Receivers with Floodlight technology capability, Top Con GRS-1 Series equipment or equal (to be approved by Program Manager prior to mobilization). GPS coordinates to be real-time or post-processed to achieve sub-meter accuracy. Equipment must have ESRI ArcPad 10.1 installed for use in data acquisition.

B. Camera

1. All camera systems used shall be digital format. The camera must have two independently or simultaneously controlled digital cameras, one facing in the downward direction and one facing in the upward direction. Each camera must have a minimum of 185 degree field of view. The inspection camera system must illuminate the interior of the manhole using a xenon strobe light. The light shall be positioned 360 degrees around the camera lens to distribute the light evenly onto the structure walls. The lighting must be able to illuminate manholes up to 120" in diameter without the need of any auxiliary lighting.

A camera must also be able to obtain still images of the following specified pictures: Photo 1- surface view photos taken of the manhole should include a whiteboard (or similar) with the manhole ID number identified on it. The photographer should be standing with the outlet pipe facing their 6 o'clock position. Photo 2 - the downhole photo of the manhole channel should be taken with the outlet pipe facing their 6 o'clock position. Additional photos as specified by MACP guidance. The camera used for these images must be minimum 5 megapixel .jpg format for sufficient clarity and detail in the photos, and photos of at least 2 MB shall be submitted. If the 3D scan camera system cannot obtain photos of sufficient quality, a pole-mounted digital camera with lighting shall be used for the specified pictures in this paragraph.

The 3D camera system shall produce individual images or frames with no more than 0.001 inches of movement during image or frame exposure to produce crisp, clear images. The inspection camera must provide a minimum of 3,000 lines of vertical resolution in the side view and a minimum of 500 lines in the perspective view.

Inadequate lighting, image distortions, blurry or murky images, low resolution, dirty lens and/or other quality issues will be a cause for rejection. If unsatisfactory, Subcontractor shall perform work until deliverable is of acceptable quality. No payment will be made for unsatisfactory inspections or until submittal is accepted.

C. Data Logger and Software

1. MACP inspections and logs created and captured electronically during the MACP inspection of the manhole through the use of commercially available electronic data loggers are required. Paper records for data collection in the field shall not be used. NASSCO MACP protocols shall be used for capturing and recording the observations.
2. The data logger equipment and software shall allow Program Manager direct access to the captured electronic data, and provide for export of the data in accordance with MACP formats and standards.

D. Retrieval of Stuck Equipment

CITY OF MEMPHIS – STANDARD CONSTRUCTION SPECIFICATIONS
SECTION 00001 – MANHOLE GPS & MACP INSPECTION
Modified by SARP10

1. The Subcontractor is responsible for hiring a licensed sub-Subcontractor to retrieve any equipment that becomes lodged in the sewer system through the execution of the scope of work (fallen cameras, jet nozzles, inflatable plugs, sandbags etc.) at the Subcontractor's own cost. Such retrieval by an appropriately licensed sub-Subcontractor shall be made within 72 hours to avoid interfering with the City of Memphis sewer system operations. Any and all impacts and related costs due to the Subcontractor's equipment in the line shall be the responsibility of the Subcontractor.

PART 3 – CONSTRUCTION REQUIREMENTS

3.01 INSPECTION

A. GPS Coordinates of Manhole Cover

Program Manager will provide Subcontractor with a digital copy of the original GIS source map indicating the sewer system network compiled from existing City records.

The Subcontractor shall capture and record sub-meter grade x, y and z coordinates of each manhole cover identified in the original GIS maiden data map provided with a unique asset identification (ID) number. Additional sanitary sewer lamphole and manholes found in the field in the course of the inspection work that are not provided in current mapping nor identified with a current unique asset ID shall be documented and GPS coordinates shall be recorded. A provisional manhole asset ID number shall be used by the Subcontractor by adding a dash and a two-character number to the closest upstream manhole ID.

Record sub-meter GPS coordinates in NAD83 TN State Plane Coordinates horizontal, NAVD88 vertical in US Survey feet using properly-calibrated GPS equipment. If GPS coordinates cannot be obtained due to buildings, trees or cloud cover, Subcontractor shall note this on the inspection form and return at least one additional time at a different time of day or under different sky cover. If both attempts fail at securing the sub-meter coordinates, this is to be documented and reported in the submittal. Land surveying shall not be required where GPS is not available.

The Subcontractor shall be expected to use all reasonable means to locate the lampholes and manholes in the field. This includes walking the pipeline alignment, using measuring tapes or wheels from the last found manhole, using metal detectors, or other means. If manholes are not able to be found and documented or unknown manholes are found, record the reasons for not locating or not opening the manhole or the specifics of the new manhole found, and submit with supporting MACP documentation to the Program Manager daily.

Once GPS coordinates are obtained for known and newly discovered facilities, the original GIS map data shall be delivered to the Program Manager to reflect the actual sewer system network for the assigned inspection area.

The Subcontractor shall revisit predefined GPS control locations near project area at least one time per day per each GPS unit used as a quality control check on GPS accuracy. Subcontractor is to document these checks on a single log, which shall be kept on file for the duration of the project, and shall be released to Program Manager on a weekly basis.

CITY OF MEMPHIS – STANDARD CONSTRUCTION SPECIFICATIONS

SECTION 00001 – MANHOLE GPS & MACP INSPECTION

Modified by SARP10

B. MACP Manhole Inspection

The Subcontractor shall document and record each sanitary sewer manhole inspection in MACP Level 1 format for lampholes and Level 2 format for manholes with supporting completed MACP format database. The complete NASSCO MACP Levels 1 and Level 2 protocols must be utilized for the lamphole and manhole inspections respectively, and must be associated in the electronic database and pdf documentation with the unique asset ID provided.

The Subcontractor shall mark the direction of wastewater flow (one arrow per pipe) in and out of the manhole around the perimeter of the manhole cover on the street with discrete green arrows spray painted onto the road surface using a guide or template for the arrows. The arrows shall be a minimum of 12 inches and a maximum of 18 inches in length.

The Subcontractor shall follow the prescribed MACP Level 1 and Level 2 procedures and use the required nomenclature and formats to document the manhole interior and exterior conditions and defects.

Subcontractor shall be responsible for cleanup, repair, fines, property damage costs, and claims for any sewage backup, spillage or sanitary sewer overflow during or as a result of the field operations.

C. Camera Inspection of Manholes and Associated Pipe Connections

For manholes greater than 25-feet in depth and manholes associated with lines 36-inches and larger in diameter, a 3D manhole scan shall be completed in conjunction with Level 2 manhole inspections of defects and include each sewer pipe connection in the manhole. The photo record of the inspection shall document defects and leaks and shall include a photo record of the connecting pipes in each manhole. Abbreviations, naming conventions, and numbering conventions shall be documented in MACP formats.

File naming must be consistent. Additional instructions, naming conventions, file structures, etc. will be provided after contract award.

D. Manhole Steps Removal

Contractor shall removal of all manhole steps that could entangle any air hoses, safety lines and personnel stages.

CITY OF MEMPHIS – STANDARD CONSTRUCTION SPECIFICATIONS
SECTION 00001 – MANHOLE GPS & MACP INSPECTION
Modified by SARP10
PART 4 – DELIVERABLES

4.01 RECORDS

A. GPS Manhole Cover Coordinates

Subcontractor's Level 1 Manhole and Level 2 Manhole GPS coordinate delivery to the Program Manager shall be in an ESRI ArcPAD .axf file format. The updated GIS source map data reflecting the actual sewer system network shall also be delivered. Inspection data is to be delivered to the Program Manager by the close of business on the Monday following a week after data acquisition. Subsequent data will not be accepted if GPS data is not obtained and delivered at the same time as inspection is conducted. The requested GPS control check file (MS EXCEL) shall also be delivered at this time.

B. Level 1 and Level 2 Inspection Documentation

Deliver complete MACP Level 1 for lampholes and Level 2 inspections for manholes in MACP electronic database and pdf electronic formats on an external hard drive. Delivery will be in MS ACCESS database format unless otherwise preapproved by the Program Manager. Inspection data is to be delivered to the Program Manager by the close of business on the Monday following a week after data acquisition.

C. 3D Camera Inspection

For manholes greater than 25-feet in depth or associated with lines 36-inches or greater in diameter, the Subcontractor shall provide the Program Team with the software required to view the digital film file in the way the Subcontractor can view it, including full control of the virtual pan and tilt. The digital files must include the following:

1. An unfolded view of the manhole with a minimum of 3,000 lines of vertical resolution.
2. The capability to produce three-dimensional representation of the manhole structure.
3. A distortion-free virtual pan and tilt allowing the review of the manhole structure from any angle at any depth. The virtual pan and tilt must consist of view from the bottom and top camera, any virtual pan and tilt that artificially creates this view from a single camera will be deemed unacceptable due to distorted images on the direct side view.

D. Camera Inspection Documentation

Include specified camera photo documentation of defects, leaks and pipe connections in the MACP Image reference field as appropriate, for the Level 2 documentation. Inspection data is to be delivered to the Program Manager by the close of business on the Monday following a week after data acquisition.

E. Manhole Reports

Deliver a summary report in PDF format of each manhole inspected. The report will include all MACP Level 1 & Level 2 data collected for the manhole. The report shall include the surface view photo of the manhole with the outlet pipe facing 6 o'clock as well as a downhole photo of the channel with the outlet pipe at 6 o'clock. Any defects noted in the manhole shall also have an accompanying photo in the report.

CITY OF MEMPHIS – STANDARD CONSTRUCTION SPECIFICATIONS

SECTION 00001 – MANHOLE GPS & MACP INSPECTION

Modified by SARP10

F. Draft Report and Final Report

In addition to the electronic database and pdf format reports, three copies of the Draft Report will contain hard copies of each of the MACP inspections with camera manhole defect and pipe connection photographs. The MACP compliant database of the inspections in ACCESS format shall also be submitted to the Program Manager electronically on an external hard drive.

Draft Report shall be delivered to Program Manager within fifteen working days of the last or final inspection. The Program Manager will have a two workweek period to review and provide comments to the Subcontractor. The Subcontractor shall address all comments and submit the Final Report within one workweek from receipt of comments. At the Program Manager's discretion, a meeting will be held upon submittal of the Final Report to have the Subcontractor go over the processes used to address comments.

F. Quality

Rejection of deliverables will be submitted to the Subcontractor via the Program Team in a written communication discussing issues that must be addressed. The Subcontractor will be required to follow up with a response within three business days upon receipt of the written communication. Subcontractors will have seven (7) calendar days from the rejection notice date to make the necessary corrections and resubmit the data deliverable in its entirety.

PART 5 – MEASUREMENT

5.01 GPS COORDINATES OF MANHOLE COVER

The capture and associated documentation of sub-meter GPS x, y and z coordinates for each lamphole and manhole cover will be measured for payment per each lamphole and manhole located by GPS and its coordinates recorded in accordance with the specification, provided that documentation meets QA/QC standards.

5.02 MACP LEVEL 2 FOR MANHOLE INSPECTIONS

The inspection and recording of all manhole observations in a MACP compliant fashion will be measured for payment per each manhole inspected in accordance with the specification. For manholes greater than 25-feet in depth or associated with lines 36-inches in diameter or greater, a 3D manhole scan shall be included as part of the MACP Level 2 inspection.

5.03 REMOVAL OF ALL MANHOLE STEPS

Removal of all Manhole Steps shall be measured by a per each step removed.

PART 6 – PAYMENT

6.01 GPS COORDINATES OF MANHOLE COVER

The capture and associated documentation of sub-meter GPS x, y and z coordinates for each manhole cover shall be paid for at the unit price bid for each lamphole and manhole cover coordinates documented and recorded in accordance with the specification provided that QA/QC standards are met.

CITY OF MEMPHIS – STANDARD CONSTRUCTION SPECIFICATIONS
SECTION 00001 – MANHOLE GPS & MACP INSPECTION
Modified by SARP10

The unit price for each manhole cover GPS set of coordinates shall cover the entire cost of the GPS equipment and time necessary to gather the coordinates, including but not limited to calibrating the equipment; setup and access; traffic control; documenting results in prescribed MACP electronic formats, records and logs; power supply for equipment; interim and final reports; and all other appurtenant work.

No additional payment will be made for:

- a. Location or re-inspection due to cars parked over manholes or other impediments to on grade and showing manhole covers.
- b. Additional visit(s) to secure the proper GPS coordinates due to lack of adequate satellite coverage or reception.
- c. Unapproved duplication of inspection. The Subcontractor is responsible to ensure duplications do not occur.

6.02 MACP LEVEL 2 FOR MANHOLE INSPECTIONS

The inspection and recording of all manhole observations in a MACP format shall be paid for at the unit price bid per each MACP Level 2 inspection performed in accordance with the specification, provided that QA/QC standards are met.

The unit price for each MACP manhole inspection shall cover the entire cost of the inspection and reporting, including but not limited to setup and access, documenting results in records and logs, digital photos, power supply for equipment, interim and final reports, and all other appurtenant work. This also includes the materials and labor to complete 3D scan of the manhole with all associated deliverables where applicable.

6.03 REMOVAL OF ALL MANHOLE STEPS

The unit price shall cover the entire cost of removing all steps in the manhole.

6.04 PAYMENT WILL BE MADE UNDER:

<u>Item No.</u>	<u>Pay Item</u>	<u>Pay Unit</u>
00001-6.01	GPS COORDINATES OF MANHOLE COVER	EACH
00001-6.02	MACP LEVEL 2 MANHOLE INSPECTIONS WITH 3D SCAN	EACH
00001-6.03	REMOVAL OF ALL MANHOLE STEPS	EACH

END OF SECTION 00001

CITY OF MEMPHIS – STANDARD CONSTRUCTION SPECIFICATIONS
Modified by SARP10 Program
SECTION 00003 - CLOSED CIRCUIT TELEVISION INSPECTION
OF SEWER MAINS & CONNECTIONS

PART 1 – SCOPE

- 1.01 This Work will consist of cleaning and Pipeline Assessment Certification Program (PACP) internal closed circuit television (CCTV) surveys to digitally inspect and record conditions of existing sanitary sewer mains and connections. Sewer pipes and connections to be inspected are located in both improved streets, arterial and primary roads, backyards and unimproved easements.
- 1.02 The Work covered by this section includes furnishing all labor, competent PACP certified technicians, equipment, tools, accessories, and materials required to clean and inspect the designated sanitary sewer lines.
- 1.03 PACP compliant inspections, logs, data, and photos shall be delivered to the Program Manager (from hereon Program Manager shall be interpreted as “Program Manager or his designee”) on external hard drive(s) which will become property of the Program Manager. Data files shall be formatted to facilitate upload into a PACP compliant Exchange database or internet uploads formats to an FTP site approved by the Program Manager.
- 1.04 For rehabilitation work, only Post-Rehabilitation PACP submittals will be required by the Purchaser. All CCTV done prior to rehabilitation shall be at the expense of the Subcontractor to ensure conformance with the Specifications.

PART 2 – MATERIALS & EQUIPMENT

2.01 MATERIALS

A. Submittals

1. Unless otherwise specified all sample submittals shall be delivered to the Program Manager within two weeks of the NTP.
2. Traffic Control Plan shall be submitted to the Program Manager, including the following items:
 - a. Outline of permit acquisition procedure for lane closures.
 - b. Methods for proper signing and barricades, which comply with City of Memphis requirements.
 - c. Major streets (e.g. Shelby County Principal Arterial & Minor Arterial) requiring a City approved permit if taking a lane for mobile operations, secured through Traffic Control Plan submittal to the City and signed by a TN P.E. The City requires two-week lead time for permit processing.
 - i. The Subcontractor will be required to deliver a sample primary/arterial road Traffic Control Plan for review by the City.
 - ii. If the City determines that the nature of the work operation or the type of road in which the Subcontractor is working requires a permit, the Subcontractor will be required to modify the sample Traffic Control Plan to obtain a permit from the City.

CITY OF MEMPHIS – STANDARD CONSTRUCTION SPECIFICATIONS
Modified by SARP10 Program
SECTION 00003 - CLOSED CIRCUIT TELEVISION INSPECTION
OF SEWER MAINS & CONNECTIONS

- d. For everywhere else where a permit is not required, the Subcontractor shall develop, provide, and implement a traffic control plan for all mobile operations in accordance with standard MUTCD specifications.
 - e. The Subcontractor is also responsible for acquiring all necessary disposal and/or landfill site permits as required to perform this work.
 - f. Railroad Rights of Way: The Subcontractor shall notify the Program Manager when work or access to manholes and sanitary sewers lie within the 25 feet railroad easement as measured by 25 feet outside the nearest rail of the tracks. To access sewer facilities within the 25 feet of the railroad right of way the Subcontractor shall contact the Program Manager 48 hours in advance who will alert the City's Zone Construction Inspector to coordinate individual railroad direction and guidance.
3. Permit required confined space entry plans in compliance with the Loss Control Manual.
 4. Copies of National Association of Sewer Service Companies (NASSCO) certification for all field staff conducting PACP inspections.
 5. Sample of PACP compliant television survey log in MS Access format.
 6. Sample of PACP compliant video inspection in MP-4 (Web optimized) format.
 7. Cleaning and CCTV vehicle, equipment, and cleaning supplies list.
 8. Disposal site(s) and appropriate landfill permits for appropriate disposal of all waste materials removed from the sewer during the light and heavy cleaning operations.

2.02 EQUIPMENT

A. General

1. All equipment used for PACP compliant CCTV sewer segment inspections of existing sanitary sewer mains and connections shall be specifically designed and manufactured for the purpose intended under this Contract. The software and hardware for the electronic capture of the inspection defects and recorded observations must be Version 6.0.1NASSCO PACP compliant.
2. The Subcontractor shall submit an equipment list to the Program Manager for approval before the commencement of the Work and shall certify that back-up equipment is available and can be delivered to the worksite within 72 hours.
3. The Subcontractor shall provide equipment to perform inspections of sewer mains located in streets, street rights-of-way, backyards, easements and rights-of way that are off-road.
 - a. Including but not limited to portable CCTV equipment, vehicles capable of transporting TV equipment and accessing remote easements, and adequate cleaning equipment rights of way or easement applications.

CITY OF MEMPHIS – STANDARD CONSTRUCTION SPECIFICATIONS
Modified by SARP10 Program
SECTION 00003 - CLOSED CIRCUIT TELEVISION INSPECTION
OF SEWER MAINS & CONNECTIONS

B. PACP Compliant Software & Data Logger Requirements

1. Data logger

- a. Internal inspection logs created and captured electronically during the television inspection through the use of commercially available electronic data loggers in the truck are required. NASSCO PACP protocols Version 6.0.1 shall be used for capturing and recording the observations. Audio commentary made during the inspection and captured on the digital video shall correspond with the PACP observations on the log.
- b. The data logger equipment and software shall allow the Program Manager access directly to the captured electronic data and provide for a non-proprietary export of the data into MS ACCESS databases in accordance with PACP standards for standalone database review.

2. Software must be compliant with the NASSCO PACP V.6.0.1 standards. Follow PACP protocol for recording of observations and defects for sewer mains.

- a. All software shall be capable of providing complete survey reports in compliance with PACP, and the software shall be the V.6.0.1 of the PACP compliant software.
- b. The Program Manager has no intent to specify which software the Subcontractor shall use, but requires the software and the submitted database to be fully compliant with PACP V.6.0.1 and capable of being exported to ACCESS databases. No payment will be rendered for improperly formatted data.
- c. Software and data logger must be capable of capturing sewer main and sewer lateral observations by PACP descriptions, record travel footage along pipeline, and video time stamp the recorded observations to support hyper linking from the digital record to the event point or location within the digital inspection record. The same requirements apply to still photo images (if provided) which shall follow PACP guidelines and be hyperlinked to the inspection log.

C. Sewer Main CCTV

1. Sewer Main Digital Color Video Camera

- a. All cameras used shall be digital format color CCTV units specifically designed and constructed for use in sewer pipe inspection work. The cameras shall be operable in 100 percent humidity conditions. The camera shall have a high-resolution, 360-degree pan and tilt or rotating head with a wide viewing angle lens and either automatic or remote focus and iris controls. Camera lighting shall be sufficient for use with digital color inspection cameras and for the manhole and pipe diameters identified in the contract.
 - i. Camera, Television Monitor, and Other Components shall be capable of producing a high resolution color digital inspection record.

CITY OF MEMPHIS – STANDARD CONSTRUCTION SPECIFICATIONS
Modified by SARP10 Program
SECTION 00003 - CLOSED CIRCUIT TELEVISION INSPECTION
OF SEWER MAINS & CONNECTIONS

- ii. Video file to be in MP-4 (Web optimized) format
- b. In all cases, the complete digital inspection system (camera, lens, lighting, cables, monitors, and recorders) shall be capable of providing a digital picture and digital video quality acceptable to the Program Manager. Inadequate lighting, image distortions, blurry or murky images, and dirty lenses will be a cause for rejection. No payment will be made for unsatisfactory inspections and the Subcontractor shall perform work until deliverable is of acceptable quality. Digital video cameras/digital recorders not specifically intended for use for internal television inspection of manholes and sewer lines shall not be permitted.
- c. Pan and tilt type camera, capable of turning at right angles to pipe's axis over an entire pipe wall perimeter shall be used.
 - i. The camera lens shall be capable of self-righting itself after a lateral view or connection view with a return view down the pipe with a "home" capability for the lens.
- d. Lighting shall be suitable to allow clear picture of entire inner pipe wall extending at least 10 feet in front, including black High Density Polyethylene (HDPE) pipe.
- e. Document header and observations shall be in accordance with PACP V.6.0.1 protocols.
- f. Subcontractor shall have equipment capable of cleaning and assessing 12" and smaller diameter siphons.

D. Cleaning Equipment

1. Hydraulic sewer pipe cleaners or combination hydraulic/vacuum cleaners shall be specifically designed and constructed for such cleaning.
2. Mechanical sewer pipe cleaners shall be specifically designed and constructed for such cleaning.
3. The Subcontractor shall possess equipment capable of hydraulically or mechanically cleaning a minimum of 1,000 linear feet of pipe from one direction and have a minimum 1,000 linear feet of hose or cable on-site during the cleaning execution.
4. Hydraulic sewer pipe cleaners shall be specifically designed and constructed for such cleaning. The sewer cleaner shall have a minimum usable water capacity of 600 gallons and a pump capable of delivering at least 30 gallons per minute at 1,500 psi at the nozzle.
 - a. The hydraulic cleaning equipment shall have multiple hydraulic cleaner hose nozzles for a variety of sewer cleaning conditions, including grease, roots, debris and granular materials.
 - b. Vacuum equipment shall be capable of lifting debris removed from the segment from the downstream manhole.

CITY OF MEMPHIS – STANDARD CONSTRUCTION SPECIFICATIONS
Modified by SARP10 Program
SECTION 00003 - CLOSED CIRCUIT TELEVISION INSPECTION
OF SEWER MAINS & CONNECTIONS

5. Mechanical sewer pipe cleaners (cable machines with buckets, brushes, swabs, root cutters, and power rodders with similar capability) shall be capable of controlled forward and reverse travel through the sewers without inflicting damage to the existing pipe in removing rocks, grit and other heavy debris and roots.

PART 3 – CONSTRUCTION REQUIREMENTS

3.01 CCTV Inspection of Sewer Mains

A. Cleaning

1. Sewer pipe cleaners or combination hydraulic-vacuum cleaners must accompany CCTV units at all times. Ideally, sewers lines are to be cleaned and then followed immediately by CCTV inspection. All sewers must be cleaned in advance of CCTV during the same calendar day they are inspected.
2. Light Cleaning
 - a. Before CCTV work, the Subcontractor shall light clean the sewer line from manhole to manhole, from upstream to downstream direction unless an obstruction is encountered, one sewer section at a time and performed as efficiently as possible at the Subcontractor's discretion.
 - b. Materials shall not be passed from one sewer segment to another but must be trapped and removed from each sewer segment prior to CCTV inspection.
3. Heavy Cleaning
 - a. If a camera is inserted and additional debris or impediments to inspection are observed following the required light cleaning, heavy cleaning shall be approved by the Program Manager. Sections of pipe containing significant roots, large areas of debris, and/or several inches of depth of sands and gravels that will require the use of additional hydraulic nozzles, cable/bucket machine, power rodders and root cutters is considered heavy cleaning.
 - b. Heavy cleaning will be proposed by the Subcontractor and approved by the Program Manager. The Subcontractor must obtain prior approval for heavy cleaning in each sewer segment in order to receive payment for heavy cleaning.
4. Cleaning Execution
 - a. No roots, grease or debris from light or heavy cleaning shall be passed from sewer segment to sewer segment during the cleaning operation. All debris flushed from the sewer must be collected, captured, and removed from the sewer at the downstream manhole.
 - b. Roots shall be removed in the sections where root intrusion is a problem. Special precautions shall be exercised during the cleaning operation to assure complete removal of visible roots from the joint area and so as not to incur further damage to the pipe. Any visible roots that may impact rehabilitation efforts shall be removed. Fine roots are allowed if the Subcontractor made a heavy cleaning attempt to remove roots with proper

CITY OF MEMPHIS – STANDARD CONSTRUCTION SPECIFICATIONS
Modified by SARP10 Program
SECTION 00003 - CLOSED CIRCUIT TELEVISION INSPECTION
OF SEWER MAINS & CONNECTIONS

root removal means. Procedures may include the use of mechanical devices such as rodding machines, expanding root cutters and porcupines, and hydraulic procedures such as high-pressure jet cleaners.

- c. The Subcontractor is responsible for safe, responsible and legal handling and disposal of all material and debris removed from the sewers. The Subcontractor is responsible for all permits and landfill fees associated with the disposal of debris collected and removed from the sewer.
- d. The Subcontractor shall provide a dated manifest of the volume or weight of the dewatered sewer cleaning loads taken and dumped at the permitted dump site selected by the Subcontractor. Each waste load manifest shall be associated with a list of corresponding sewer segments from where the waste originated.
- e. Siphons shall be cleaned to remove 95% of the debris from the pipe.

B. Sewer Flow Levels During Inspection Operations

- 1. Maintain low sewer flow during inspection by using sandbags or flow-through plugs or by inspecting during low flow times of day, evening, or early morning hours while camera is moving and recording observations in the sewer segment. Any items used to restrict flow shall be removed immediately after intended use.
 - a. Flow-through Plugs: If used, secure the plugs so as to remain in place during inspection. Use a fail-safe device at the downstream pipe connection to ensure the plug is not lost in the downstream sewer segment if it becomes dislodged from the upstream pipe connection.
 - b. Conduct all cleaning and CCTV operations to prevent building backups and sewer overflows.
 - c. Subcontractor shall be responsible for cleanup, repair, fines, property damage costs, and claims for any sewage backup, spillage or sanitary sewer overflow during or as a result of the cleaning and inspection operations.
- 2. Allowable Depth of Flow For Inspection Operations
 - a. For effective inspection, all flow shall be minimized in the segment being inspected. However, the depth of flow at the upstream manhole of the interceptor section being worked shall be within the specified limits provided herein.
- 3. Maximum Allowable Depth of Flow for CCTV Inspection
 - a. 6 - 10 inch diameter Pipe - 20% of pipe diameter
 - b. 12 - 18 inch diameter Pipe - 25% of pipe diameter
 - c. 24-inch diameter and Larger Pipe - 30% of pipe diameter
 - d. Exceptions to these guidelines shall result in rejection, and non-payment, of the CCTV inspection unless approved in advance by the Program Manager.

CITY OF MEMPHIS – STANDARD CONSTRUCTION SPECIFICATIONS
Modified by SARP10 Program
SECTION 00003 - CLOSED CIRCUIT TELEVISION INSPECTION
OF SEWER MAINS & CONNECTIONS

C. Camera Operations

1. Using the pan/tilt feature, pan the interior of the manhole for record purposes in accordance with V.6.0.1 PACP protocols and begin and terminate the inspection in the starting and ending manholes.
 - a. Capture the inside of manhole walls, manhole channel, and pipe connection to wall at both upstream and downstream manhole and lateral connections using the digital mainline sewer camera and the pan/tilt feature.
2. Place the camera at center of manhole and commence video before entering pipe.
 - a. Start footage counter at manhole wall/pipe connection or at a short pre-measured distance down the pipe for the sewer segment inspection.
3. Connections: The digital camera shall be used to look at connections and up laterals from the connection in the main sewer pipe being inspected. The camera shall pause, pan, and record all connections. Conditions noted in these sidelines and laterals shall be noted on the inspection logs.
4. Mainline camera operations:
 - a. Move through line at speed no greater than 30 feet per minute stopping for minimum 10 seconds to record lateral connections, mainline connections, defects, and features and points of interest.
 - b. Do not float camera.
 - c. Maintain technical quality, sharp focus, and distortion free picture with the camera lens centered in the pipe for the different diameters inspected.
 - i. Eliminate steam in line for duration of inspection.
 - ii. Utilize blower as needed to defog sewer line.
 - d. Digitally record a complete sewer segment in its entirety with no breaks, "blink-outs," or interruptions from manhole to manhole according to PACP V.6.0.1 formats.
 - e. Pan, tilt, and rotate as necessary to best view and evaluate lateral connections, pipe defects, features, obstructions, and points of interest.
 - f. Use power winches, powered rewinds, self-propelled tractors, or other devices that do not obstruct camera view or interfere with proper documentation of sewer conditions to move camera through sewer.
 - i. Whenever non-remote powered and controlled winches are used, set up telephones or other suitable means of communication between manholes to insure good communication.
 - g. Use hydraulic jet nozzle pressure and flow to remove standing water from depressions or sags in the sewer, if necessary, for complete inspection of the sag portion of the sewer segment.

CITY OF MEMPHIS – STANDARD CONSTRUCTION SPECIFICATIONS
Modified by SARP10 Program
SECTION 00003 - CLOSED CIRCUIT TELEVISION INSPECTION
OF SEWER MAINS & CONNECTIONS

- h. Measurement for location of defects and service laterals:
 - i. At ground level by means of Program Manager-approved footage counter or metering device.
 - ii. Electronic display measurement meters: Accurate to PACP standards over length of section being televised.
 - iii. Do not pull unnecessary length of slack camera cable if it impacts the footage counter.
- i. Stop camera at service connections and inspect lateral with pan and tilt camera.
 - i. Identify building connection in PACP compliant terms as active, capped, or abandoned.
 - ii. If no wastewater flows are being discharged from building, consider steady, clear observed flow as infiltration/inflow.
- j. Identification of defects
 - i. If roots, sludge, or sediment material impedes inspection after the light cleaning, withdraw camera and perform heavy cleaning at the direction of the Program Manager.
 - ii. Upon completion of heavy cleaning operation, resume internal inspection.
 - iii. Furnish media confirmation for heavy cleaning (more than three passes with jet cleaner) to Program Manager.
 - iv. If protruding tap impedes inspection trim protruding tap to 1/2 inch.
- k. If obstructions are not passable and cannot be removed by sewer cleaning, withdraw CCTV equipment and perform a reverse inspection from opposite end of the sewer segment in accordance with PACP protocols.
 - i. Subcontractor shall be responsible for costs associated for reverse set-ups when an obstruction is encountered that cannot be passed.
 - ii. Subcontractor shall be responsible for all judgments and impacts as to whether an obstruction in the sewer main can be passed. Costs involved in extracting a stuck camera in the sewer main will be borne by the Subcontractor and at no additional cost to the Program Manager.
 - iii. When additional obstructions are encountered after reversal of equipment and no means are available for passing a second obstruction in order to complete the sewer main inspection, remand the segment inspection to the Program Manager for resolution. The portion of the main inspected will be paid for as prescribed.

CITY OF MEMPHIS – STANDARD CONSTRUCTION SPECIFICATIONS
Modified by SARP10 Program
SECTION 00003 - CLOSED CIRCUIT TELEVISION INSPECTION
OF SEWER MAINS & CONNECTIONS

- I. Undocumented facilities
 - i. If undocumented manholes or sewer mains (facilities not on the field updated GIS sewer maps) are encountered during the inspection, the Subcontractor needs to complete the documentation requirements per PACP requirements and capture on the video the following:
 - 1. Approximate horizontal distance from the upstream or reference manhole.
 - 2. Approximate depth of the undocumented manhole by turning the pan/tilt camera vertically and estimating the height of the cover from the invert.
 - 3. A provisional manhole asset ID number shall be used by the Subcontractor by adding a dash and two-character number to the closest upstream manhole ID.
 - m. Retrieval of Stuck Equipment
 - i. The Subcontractor is responsible for hiring a licensed sub-Subcontractor to retrieve any equipment/foreign objects that get stuck in the sewer system through the execution of the scope of work (fallen cameras, jet nozzles, inflatable plugs, sandbags etc.) at the Subcontractor's own cost. Such retrieval by an appropriately licensed sub-Subcontractor shall be made within 72 hours to avoid interfering with the City of Memphis sewer system operations. Any and all impacts and related costs due to the Subcontractor's equipment in the line shall be the responsibility of the Subcontractor. Subcontractor shall follow SARP10 sewer point repair specifications outlined in "Section 02540 Sanitary Sewer Point Repairs" and "Section 02950 Removal and Replacement of Pavements and Incidentals" during retrieval of equipment. Also per "00585.2.2 Safety, Health, and Accident Prevention Program," Purchaser must approve sub-tier Subcontractors prior to mobilization to the jobsite.

D. Quality Assurance

- 1. With each monthly invoice the Subcontractor shall provide a QA/QC memo documenting that 10% of the previous month's CCTV data has undergone a random, independent review by a PACP certified reviewer using NASSCO standards for Television Inspection of Main Sewer and PACP Quality control as the basis for the QA/QC procedures. The independent reviewer shall be a Tennessee P.E. or is a P.E. in another state and has a Tennessee P.E. license pending. Each line segment which has been randomly reviewed shall be identified in the QA/QC memo as well as any subsequent findings or recommendations. Internal independent QA/QC is acceptable, as long as the person is a Tennessee P.E. or is a P.E. in another state and has a Tennessee P.E. license pending. Failure to submit the QA/QC memo shall delay payment of the current month's invoice.
- 2. For all new Subcontractors and Operators who begin PACP coding, an initial review of CCTV data will consist of reviewing, at a minimum, 20 of the first 100 PACP inspection records submitted. Subsequent reviews will be based on the results of the initial reviews as explained below.

CITY OF MEMPHIS – STANDARD CONSTRUCTION SPECIFICATIONS
Modified by SARP10 Program
SECTION 00003 - CLOSED CIRCUIT TELEVISION INSPECTION
OF SEWER MAINS & CONNECTIONS

3. Auditing Procedures:

a. Header Information: As explained in the NASSCO PACP Quality Control Standards each audited inspection record is given an accuracy level for the header information and the detailed observation records. It is expected that the accuracy of the header record exceed 90% because the majority of the contents are based upon facts and not subject to operator judgment. To assess the accuracy level of the header, record the number of errors as compared to the total number of header fields using the following formula:

$$100\% - (\text{error count}/\text{total header fields}) * 100\% = \text{Header Accuracy}$$

b. Detailed Observations: Determining the accuracy level for the detailed observation records is similar to the method for assessing the header record. The main difference being that a defect observation has multiple data entries that must also be counted towards the total number of entry fields. In the event that a defect is not coded all of the required entries for coding the missed defect are counted towards the total error count. The following formula is used to calculate the accuracy level of the detailed observation records:

$$100\% - (\text{error count}/\text{total entries}) * 100\% = \text{Detail Accuracy}$$

c. Review Scoring and Results

- i. Satisfactory Review, No changes required. Accuracy Level of 90% or above for both the Header Record and Observation Detail with no major errors or omissions found.
- ii. Unsatisfactory Review (below levels of acceptance) will not be accepted by the Program Manager and will not be considered payable items in the Subcontractor's Request for Payment.

E. Deliverable Documentation

1. Mainline Sewer

- a. Submit V.6.0.1 PACP compliant records, logs, and electronic inspection data for sewer line inspection to Program Manager by the close of business on the Monday following a week after data acquisition.
- b. Monthly QA/QC memo submittal listing which segments have been randomly reviewed, as well as any subsequent findings or recommendations.
- c. Digital videos, data, and photos shall be delivered to the Program Manager on external hard drives which will become property of the Program Manager.
- d. Data files shall be formatted to facilitate upload into a PACP Exchange Database with the approval of the Program Manager.
- e. Inspections displaying poor digital video/audio quality will be rejected. Quality refers to, but is not limited to, grease or debris on lens, camera under water, image too dark or light, image washed-out, distorted image, out of focus images, lines improperly cleaned, and poor/no audio.

CITY OF MEMPHIS – STANDARD CONSTRUCTION SPECIFICATIONS
Modified by SARP10 Program
SECTION 00003 - CLOSED CIRCUIT TELEVISION INSPECTION
OF SEWER MAINS & CONNECTIONS

- f. Subcontractor will re-televiser rejected inspections and resubmit inspections at no additional cost to the Program Manager.
2. Map changes/undocumented manholes:
- a. For map changes identifying undocumented manholes and network changes which were found as a result of field inspections or observations, a Map Edit Form shall also be prepared and supplied by the Subcontractor with a drawing or sketch and shall indicate special details, field measurement or distances, or locations about an observed undocumented manhole or a change to the sewer network. The Map Edit Form should also identify buried manholes and siphons that have been encountered.
 - b. Subcontractor shall indicate all buried manholes identified in the field via CCTV using the provided Buried Manhole Form. Any additional manholes that have not been located or verified via CCTV but are impeding the completion of required CCTV work should be designated as unable to locate (UTL) and be included on the form.
- F. Easement or Turf Operation
- 1. The Subcontractor will restore the work area to its original condition as quickly as possible after the inspection is complete. The Subcontractor will not be allowed to postpone restoration of the site until the end of the project.

PART 4 –DELIVERABLES

4.01 RECORDS

A. Pipe Cleaning Record

- 1. The Subcontractor shall provide a dated manifest of the volume or weight of the dewatered sewer cleaning loads taken and dumped at the permitted dump site selected by the Subcontractor. Each waste load manifest shall be associated with a list of corresponding sewer segments from where the waste originated.

B. Digital Inspection Record

- 1. In the digital PACP V.6.0.1 compliant format, the Subcontractor shall provide the following information:
 - a. Digital CCTV survey inspection which shall be recorded and shall be continuous as the inspection proceeds through the manholes and sewer pipes. Inspection videos should be delivered in an MP-4 (Web optimized) format.
 - b. Digital Recordings: The digital recording shall document the visual and audio record of the manhole and sewer pipe inspection and shall be the basis of measurement and payment. Digital recording playback shall be at the same speed that it was recorded. Original digital recordings for the Project shall be forwarded to the Program Manager on clearly labeled external hard drive(s) in PACP ACCESS format with final report submittals and shall become the

CITY OF MEMPHIS – STANDARD CONSTRUCTION SPECIFICATIONS
Modified by SARP10 Program
SECTION 00003 - CLOSED CIRCUIT TELEVISION INSPECTION
OF SEWER MAINS & CONNECTIONS

property of the Program Manager. Data for a single facility asset will not be split across multiple hard drives. Digital recordings shall be available to the Program Manager by the close of business on the Monday following a week after data acquisition. File naming must be consistent. Additional instructions, naming conventions, file structures, etc. will be provided after contract award.

- i. Picture Quality: The sewer inspection digital record shall be free of steam, fog, vapor, or other headspace distortion that degrades the quality of the picture from the intended purpose of evaluating the sewer for structural and watertight integrity. If necessary, the Subcontractor shall provide positive ventilation or other means through the sewer pipe to draw out steam, fog, and vapor that will degrade the recorded image of the pipe.

C. Inspection Documentation Logs

1. Observations made during television inspection shall be documented in an unmodified PACP compliant manner within an electronic inspection log form, supported by accompanying audio, digital photographs and MP-4 (Web optimized) format recording written to an external hard drive and submitted to the Program Manager. Hard copies of completed inspection log photographs shall be furnished to the Program Manager with invoicing.

D. Electronic & Hard Copy Records

1. Reports:
 - a. The Subcontractor shall prepare printed inspection log reports for each associated sewer pipes inspected during the actual field inspection activities. These field logs shall then be reviewed by the Subcontractor's technical staff, along with reviewing the associated digital video record, as a means of ensuring that no defects or entries are omitted or incorrect. Edited field logs shall then be used in the final project reports and submitted in pdf format.
2. Draft Report and Final Report:
 - a. The Draft Final Report will contain electronic and hard copies of each of the PACP CCTV log pipe segment inspection logs. Digital recordings of the inspections written to an external hard drive and the PACP compliant database of the inspections in ACCESS format shall also be submitted in electronic and pdf format.
 - b. Draft Report shall be delivered to the Program Manager within fifteen working days the last or final inspection. The Program Manager will have two work weeks to review and comment. Subcontractor shall address all comments provided and submit a Final Report within one work week upon receipt of comments. At the Program Manager's discretion a meeting will be held so the Subcontractor can explain the processes used to address the comments.

E. Quality

1. Rejection of deliverables will be submitted to the Subcontractor via the Program Team in a written communication discussing issues that must be addressed.

CITY OF MEMPHIS – STANDARD CONSTRUCTION SPECIFICATIONS
Modified by SARP10 Program
SECTION 00003 - CLOSED CIRCUIT TELEVISION INSPECTION
OF SEWER MAINS & CONNECTIONS

The Subcontractor will be required to follow up with a response within three business days upon receipt of the written communication. Subcontractors will have seven (7) calendar days from the rejection notice date to make the necessary corrections and resubmit the data deliverable in its entirety.

CITY OF MEMPHIS – STANDARD CONSTRUCTION SPECIFICATIONS
SECTION 00004- CLOSED CIRCUIT TELEVISION & SONAR INSPECTION
OF LARGER DIAMETER SEWER MAINS
Modified by SARP10
PART 1 – SCOPE

- 1.01 This Work will consist of assessment, Pipeline Assessment Certification Program (PACP) internal closed circuit television (CCTV), and Sonar surveys to digitally inspect and record conditions of existing sanitary sewer mains and connections in 24-inch and larger diameter sanitary sewer pipe and siphons. Larger diameter sewer pipes to be inspected are located in both improved streets, arterial and primary roads, backyards and unimproved easements. No cleaning of the sanitary sewer is required prior to CCTV and Sonar inspection.
- 1.02 The Work covered by this section includes furnishing all labor, competent PACP certified technicians, equipment, tools, accessories, and materials required to CCTV and Sonar inspect the designated 24-inch diameter and larger sanitary sewer lines.
- 1.03 PACP compliant inspections, logs, data, and photos shall be delivered to the Program Manager (from hereon Program Manager shall be interpreted as “Program Manager or his designee”) on external hard drives which will become property of the Program Manager. Data files shall be formatted to facilitate upload into a PACP compliant exchange database or internet uploads formats to an FTP site approved by the Program Manager.

PART 2 – MATERIALS & EQUIPMENT

2.01 MATERIALS

A. Submittals

1. Unless otherwise specified all sample submittals shall be delivered to the Program Manager within two weeks of the NTP.
2. Traffic Control Plan shall be submitted to the Program Manager, including the following items:
 - a. Outline of permit acquisition procedure for lane closures.
 - b. Methods for proper signing and barricades, which comply with City of Memphis requirements.
 - c. Major streets (e.g. Shelby County Principal Arterial & Minor Arterial) requiring a City approved permit if taking a lane for mobile operations, secured through Traffic Control Plan submittal to the City and signed by a TN P.E. The City requires two-week lead time for permit processing.
 - i. The Contractor will be required to deliver a sample primary/arterial road Traffic Control Plan for review by the City.
 - ii. If the City determines that the nature of the work operation or the type of road in which the Contractor is working requires a permit, the Contractor will be required to modify the sample Traffic Control Plan to obtain a permit from the City.
 - d. For everywhere else where a permit is not required, the Contractor shall develop, provide, and implement a traffic control plan for all mobile operations in accordance with standard MUTCD specifications.

CITY OF MEMPHIS – STANDARD CONSTRUCTION SPECIFICATIONS
SECTION 00004- CLOSED CIRCUIT TELEVISION & SONAR INSPECTION
OF LARGER DIAMETER SEWER MAINS
Modified by SARP10

- e. The Contractor is also responsible for acquiring all necessary disposal and/or landfill site permits as required to perform this work.
 - f. Railroad Rights of Way: The Contractor shall notify the Program Manager when work or access to manholes and sanitary sewers lie within the 25 feet of railroad easement as measured by 25 feet outside the nearest rail of the tracks. To access sewer facilities within the 25 feet of the railroad right of way the Contractor shall contact the Program Manager 48 hours in advance who will alert the City's Zone Construction Inspector to coordinate individual railroad direction and guidance.
3. Site Contractor emergency phone numbers.
 4. Schedules of work on a weekly basis that will be delivered no later than 2:00 PM on Thursday for the week following with daily AM email updates of approximate crew locations each day.
 - a. Weekly schedule format shall contain the following elements:
 - i. Map format.
 - ii. Sufficient streets labeled and identified at a scale to provide clarity.
 - iii. Nature and type of crew location by map area.
 5. Permit required confined space entry plans in compliance with the Loss Control Manual.
 6. Copies of National Association of Sewer Service Companies (NASSCO) certification for all field staff conducting PACP inspections.
 7. Sample of PACP compliant television survey login MS Access format.
 8. Sample of PACP compliant video inspection in MP-4 format.
 9. CCTV and Sonar inspection vehicle and equipment supplies list.
 10. Sample of combined CCTV & Sonar inspection report.

2.02 EQUIPMENT

A. General

1. All equipment used for PACP compliant CCTV sewer segment inspections of existing larger diameter sanitary sewer mains shall be specifically designed and manufactured for the purpose intended under this Contract. The software and hardware for the electronic capture of the inspection defects and recorded observations must be Version 6.0.1 NASSCO PACP compliant.
2. All CCTV equipment requirements contained in Section 00003 – Closed Circuit Television Inspection of Sewer Mains & Connections, Paragraph 2.02 are applicable, except 2.02.D. Cleaning Equipment since pre-cleaning of the larger diameter sewers is not required.

PART 3 – CONSTRUCTION REQUIREMENTS

3.01 CCTV & Sonar Inspection of Sewer Mains

CITY OF MEMPHIS – STANDARD CONSTRUCTION SPECIFICATIONS
SECTION 00004- CLOSED CIRCUIT TELEVISION & SONAR INSPECTION
OF LARGER DIAMETER SEWER MAINS
Modified by SARP10

A. Sewer Flow Levels During Inspection Operations

1. Maintain low sewer flow during inspection by using sandbags or flow-through plugs or by inspecting during low flow times of day, evening or early morning hours while camera is moving and recording observations in the sewer segment. Any items used to restrict flow shall be removed immediately after intended use.
 - a. Flow-through Plugs: If used, secure the plugs so as to remain in place during inspection. Use a fail-safe device at the downstream pipe connection to ensure the plug is not lost in the downstream sewer segment if it becomes dislodged from the upstream pipe connection.
 - b. Conduct all cleaning and CCTV operations to prevent building backups and sewer overflows.
 - c. Contractor shall be responsible for cleanup, repair, fines, property damage costs, and claims for any sewage backup, spillage or sanitary sewer overflow during or as a result of the cleaning and inspection operations.
2. Allowable Depth of Flow For Inspection Operations:
 - a. For effective inspection, all flow shall be minimized in the segment being inspected. However, the depth of flow at the upstream manhole of the interceptor section being worked shall be within the specified limits provided herein.
3. Maximum Allowable Depth of Flow for CCTV Inspection
 - a. 24-inch diameter and Larger Pipe - 30% of pipe diameter. Flow in excess of the 30% depth of flow limitation shall include the provision for Sonar inspection for below the water surface level in addition to a raft mounted CCTV inspection for above the water level.
 - b. Exceptions to these guidelines shall result in rejection, and non-payment, of the CCTV inspection unless approved in advance by the Program Manager.

B. Camera Operations

1. When flow is in excess of the 30% depth of flow limitation, the Contractor shall include the provision for Sonar inspection for below the water surface level in addition to a raft/float mounted CCTV inspection for above the water level.
2. Raft/float supports shall be collapsible to fit through existing manhole frames associated with 24-inch diameter and larger sewers.
3. Camera Operations requirements shall be as contained in Section 00003 – Closed Circuit Television Inspection of Sewer Mains & Connections, Paragraph 3.01 are applicable for the execution of the CCTV operations with the camera mounted on a raft or float, except as modified below.
4. Contractor shall be responsible for all judgments and impacts as to whether an obstruction in the sewer main can be passed. Costs involved in extracting a stuck camera in the sewer main will be borne by the Contractor and at no additional cost to the Program Manager.

CITY OF MEMPHIS – STANDARD CONSTRUCTION SPECIFICATIONS
SECTION 00004- CLOSED CIRCUIT TELEVISION & SONAR INSPECTION
OF LARGER DIAMETER SEWER MAINS
Modified by SARP10

C. Camera & Sonar Combined Operations

1. The combination CCTV and Sonar equipment shall be capable of inspecting a length of sewer up to at least 1,000 linear feet when entry into the sewer may be obtained at each end and up to 750 feet where a self-propelled unit is used and where entry is possible from one end only.
2. Each inspection unit shall contain a means of transporting the CCTV camera or Sonar equipment in a stable condition through the sewer under inspection. Such equipment shall ensure the maintained location of the CCTV camera and Sonar equipment when used independently on or near to the central axis of a circular shaped sewer. The maximum allowable flow depth that is permissible for the combination Sonar/CCTV is equal to 75% of the pipe diameter.
3. Where the CCTV camera or Sonar head are towed through the sewer, all winches shall be stable with either lockable or ratcheted drums. All connection shall be steel or of an equally non-elastic material to ensure the smooth and steady progress of the CCTV camera or Sonar equipment through the surcharged sewer. All winches shall be inherently stable under loaded conditions.
4. Each inspection unit shall carry sufficient numbers of guides and rollers such that, when inspecting, all connecting materials are supported away from pipe and manhole structures and all CCTV & Sonar lines used to measure the CCTV camera and the Sonar head location within the sewer are maintained in a taut manner and set a right angles where possible, to run through or over the measuring equipment.
5. The CCTV Camera and Sonar head shall be positioned to reduce the risk of picture distortion. In circular sewers the CCTV camera lens and/or Sonar head shall be positioned, when possible, centrally within the “dry” area for the CCTV and centrally within the “wet” area for the Sonar head. In non-circular sewers, picture/sonar image orientation shall be taken at mid-height, unless otherwise agreed, and centered horizontally. In all instances the camera/sonar lens shall be positioned looking along the axis of the sewer. A positioning tolerance of + 10% of the vertical sewer dimension shall be allowed.
6. When the scanning Sonar is deployed, either stand alone or combined with CCTV, the speed or travel shall be limited to 4 inches per second or 20 feet per minute.
7. A General Condition 360° CCTV rotational scan must be implemented at every 50 feet interval (min) along sewers, and at all manholes and all salient, specified, defect features. More frequent scans must be made should the condition of the pipe differ from the previous scan. The tilt must not be less than 225°.
8. The color palette shall have a minimum of 16 colors with text. The Sonar image, inside the viewing area shall be in color.
9. The picture update speed shall not result in unsatisfactory picture resolution. The range of resolution shall be 1/10 inch.
10. The maximum beam width of Sonar energy pulse shall be no greater than two degrees from the center of the transducer.

CITY OF MEMPHIS – STANDARD CONSTRUCTION SPECIFICATIONS
SECTION 00004- CLOSED CIRCUIT TELEVISION & SONAR INSPECTION
OF LARGER DIAMETER SEWER MAINS
Modified by SARP10

11. The transducer shall be of the continuous scanning type, the speed of which shall be 1 second per 360° scan.
12. The Contractor is responsible for hiring a licensed sub-contractor to retrieve any equipment/foreign objects that get stuck in the sewer system through the execution of the scope of work (fallen cameras, jet nozzles, inflatable plugs, sandbags etc.) at the Contractor's own cost. Such retrieval by an appropriately licensed sub-contractor shall be made within 72 hours to avoid interfering with the City of Memphis sewer system operations. Any and all impacts and related costs due to the Contractor's equipment in the line shall be the responsibility of the Contractor. Contractor shall follow SARP10 sewer point repair specifications outlined in "Section 02540 Sanitary Sewer Point Repairs" and "Section 02950 Removal and Replacement of Pavements and Incidentals" during retrieval of equipment. Also per "00585.2.2 Safety, Health, and Accident Prevention Program", Purchaser must approve sub-tier contractors prior to mobilization to the jobsite.

D. Quality Assurance

1. QA/QC shall be as contained in Section 00003 - Closed Circuit Television Inspection of Sewer Mains & Connections, Paragraph 3.01.D. Quality Assurance.

E. Deliverable Documentation

1. Mainline Sewer:
 - a. Submit V.6.0.1 PACP compliant records, logs, and electronic inspection data for sewer line inspection to Program Manager by the close of business on the Monday following a week after data acquisition.
 - b. Digital videos, data, and photos shall be delivered to the Program Manager on external hard drives which will become property of the Program Manager.
 - c. Data files shall be formatted to facilitate upload into a PACP Database with the approval of the Program Manager.
 - d. Inspections displaying poor digital video/audio quality will be rejected. Quality refers to, but is not limited to, grease or debris on lens, camera under water, image too dark, image washed-out, distorted image, or out of focus images, lines improperly cleaned, and poor/no audio.
 - i. Contractor will re-televisualize rejected inspections and resubmit inspections at no additional cost to the Program Manager.
2. Map changes/undocumented manholes:
 - a. For map changes identifying undocumented manholes and network changes which were found as a result of field inspections or observations, a Map Edit Form shall also be prepared and supplied by the Contractor with a drawing or sketch and shall indicate special details, field measurement or distances, or locations about an observed undocumented manhole or a change to the sewer network. The Map Edit Form should also identify buried manholes and siphons that have been encountered.

CITY OF MEMPHIS – STANDARD CONSTRUCTION SPECIFICATIONS
SECTION 00004- CLOSED CIRCUIT TELEVISION & SONAR INSPECTION
OF LARGER DIAMETER SEWER MAINS
Modified by SARP10

- b. Contractor shall indicate all buried manholes identified in the field via Sonar/CCTV using the provided Buried Manhole Form. Any additional manholes that have not been located or verified via Sonar/CCTV but are impeding the completion of required Sonar/CCTV work should be designated as unable to locate (UTL) and be included on the form.
3. Sonar Reports:
- a. The Contractor shall submit two hard copies of all details, i.e. a typed “Full Detail” report for each inspection, showing the position and full text of each defect encountered and their grades. The Contractor shall also supply an overall Summary Report detailing major defects and those inspections that require attention along with a statistical report showing lengths of sewers inspected and a breakdown of sizes and lengths inspected.
 - b. The Contractor shall supply a MS ACCESS database and free issue software for both the viewing of the media files and the Sonar images from within the database.
 - c. The Sonar Inspection shall include complete structural and service assessment to the equivalent PACP standard as that obtained through conventional CCTV imagery.
 - d. The Sonar inspection shall include measurement of flow depth and debris/silt depth.
 - e. A Color High Resolution Sonar image of cross sections of the sewer must be taken (saved) every 50 feet or more frequently should the internal profile or debris/silt depth of the sewer change from the previously saved image.
 - f. These images are to be cross-referenced to the reports and database(s) for ease of retrieval.

PART 4 –DELIVERABLES

4.01 RECORDS

A. Digital Inspection Record

1. In the digital PACP V.6.0.1 compliant format, the Contractor shall provide the following information:
 - a. Digital CCTV survey and Sonar inspection which shall be recorded and shall be continuous as the inspection proceeds through the manholes and sewer pipes.
 - b. Digital Recordings: The digital recording shall document the visual and audio record of the sewer pipe inspection and shall be the basis of measurement and payment. Digital recording playback shall be at the same speed that it was recorded. Original digital recordings for the Project shall be forwarded to the Program Manager on clearly labeled external hard drive(s) in PACP ACCESS format with final report submittals and shall become the property of the Program Manager. Data for a single facility asset will not be split across multiple hard drives. Digital recordings shall be available to the Program

CITY OF MEMPHIS – STANDARD CONSTRUCTION SPECIFICATIONS
SECTION 00004- CLOSED CIRCUIT TELEVISION & SONAR INSPECTION
OF LARGER DIAMETER SEWER MAINS
Modified by SARP10

Manager by the close of business on the Monday following a week after data acquisition. File naming must be consistent. Additional instructions, naming conventions, file structures, etc. will be provided after contract award.

- i. Picture Quality: The sewer inspection digital record shall be free of steam, fog, vapor, or other headspace distortion that degrades the quality of the picture from the intended purpose of evaluating the sewer for structural and watertight integrity. If necessary, the Contractor shall provide positive ventilation or other means through the sewer pipe to draw out steam, fog, and vapor that will degrade the recorded image of the pipe.

B. Inspection Documentation Logs:

1. CCTV Records:

- a. Observations made during television inspection shall be documented in an unmodified PACP compliant manner within an electronic inspection log form, supported by accompanying audio, digital photographs and MP-4(web optimized) format recording written to an external hard drive and submitted to the Program Manager. Hard copies of completed inspection log photographs shall be furnished to the Program Manager with invoicing.

2. Sonar Records:

- a. Where combined CCTV and Sonar inspections are performed, the display in the viewing area shall show the combined CCTV and Sonar images of the sewer being inspected. The Sonar image shall be superimposed on the real CCTV image, and continuously recorded, as a combined operation at the time of the inspection resulting in a single combined video file in MP-4(Web optimized) format for each inspection.
- b. The Sonar Inspection shall include a comprehensive final report on the findings concerning major defects including fractures, displaced joints, deformation, corrosion, lateral intrusions, dominant surface features, encrustation, and debris/silt depths.

C. Electronic & Hard Copy Records

1. Reports: The Contractor shall prepare printed inspection log reports for each associated sewer pipe inspected during the actual field inspection activities. These field logs shall then be reviewed by the Contractor's technical staff, along with reviewing the associated digital video record, as a means of ensuring that no defects or entries are omitted or incorrect. Edited field logs shall then be used in the final project reports and submitted in pdf format.
2. Draft Report and Final Report: The Draft Final Report will contain electronic and hard copies of each of the PACPCCTV log pipe segment inspection logs. Digital recordings of the inspections written to an external hard drive and the PACP compliant database of the inspections in ACCESS format shall also be submitted in electronic and pdf format.
 - a. Draft Report shall be delivered to the Program Manager within fifteen working days of oldest inspection. The Program Manager will have two workweeks to

**CITY OF MEMPHIS – STANDARD CONSTRUCTION SPECIFICATIONS
SECTION 00004- CLOSED CIRCUIT TELEVISION & SONAR INSPECTION
 OF LARGER DIAMETER SEWER MAINS
Modified by SARP10**

review and comment. The Contractor shall address all comments provided and submit a Final Report within one workweek upon receipt of comments. At the Program Manager’s discretion a meeting will be held so the Contractor can explain the processes used to address the comments.

D. Meetings

1. The Program Team will arrange bi-weekly meetings (every other week) with the contractor to discuss data management and field issues.

E. Quality

1. Rejection of deliverables will be submitted to the Contractor via the Program Team in a written communication discussing issues that must be addressed. The Contractor will be required to follow up with a response within three business days upon receipt of the written communication. Contractors will have seven (7) calendar days from the rejection notice date to make the necessary corrections and resubmit the data deliverable in its entirety.

PART 5 – MEASUREMENT

5.01 CCTV & SONAR INSPECTION

- A. CCTV & Sonar inspection shall be measured by linear foot by each diameter of mainline sewer inspected and documented in accordance with the specification.

PART 6 – PAYMENT

6.01 CCTV & SONAR INSPECTION

- A. CCTV & Sonar inspection shall be paid for at the unit price for each linear foot of each diameter inspected and documented in accordance with the specification.
- B. The unit price for CCTV & Sonar inspection shall cover the entire cost of the required CCTV & Sonar inspection and reporting in accordance with PACP V 6.0.1 format, including but not limited to labor, mobilization and access, CCTV equipment, recording media, traffic control, light cleaning of mainline sewer, documenting results in PACP records and logs, digital format recordings, photo equipment, power supply for equipment, interim and final reports, and all other appurtenant work.
- C. No additional payment will be made for:
 1. Re-inspection due to rejected inspection and/or records for any reason
 2. Incomplete electronic logs for either CCTV or Sonar digital records

6.02 PAYMENT WILL BE MADE UNDER:

<u>Item No.</u>	<u>Pay Item</u>	<u>Pay Unit</u>
00004-6.01	CCTV & SONAR INSPECTION FOR EACH DIAMETER	LF

END OF SECTION 00004

CITY OF MEMPHIS – STANDARD CONSTRUCTION SPECIFICATION
Modified by SARP10 Program
SECTION 09910 – CURED IN PLACE PIPE (CIPP) INSTALLATION

PART 1 - GENERAL

1.01 CONTRACTOR LICENSE

Subcontractors must be licensed to operate in the State of Tennessee under the appropriate classification as determined by the laws of the State of Tennessee. Classification for this project shall be MU A or B- Municipal and Utility Construction.

1.02 WORK INCLUDED

- A. The work covered by this contract will be for the installation of Cured-In-Place- Pipe (CIPP) in existing sanitary sewer lines that the Program Manager has selected for inclusion in this bid package. The contractor will go to each site and will ascertain the appropriate thickness of the CIPP material needed for the repair and will measure the actual lengths. The Program Manager will review and approve the design and will inspect the installation. The pipes selected for the work shown in the bid form range in size. The lengths of each run shown on the bid form are based upon plan measurements. The contractor will be paid based upon actual lengths determined from the post construction video log which may be less or more than the original bid quantities. CCTV work shall be done and paid for in accordance with Specification Section 00004.
- B. This specification covers the general requirements for the referenced specifications, CIPP manufacturer and installer qualifications, submittal and guaranty guidelines, materials, pre-installation and installation procedures, and testing.
- C. The object of this work is to pro-actively rehabilitate those sanitary sewers selected for this contract since failure could be very disruptive, hazardous to public health, and/or very expensive to repair after failure. It is critical that both the Product and the Installer have the ability to meet or exceed all requirements of the Program Manager. The intent of this Specification is to cover the minimum acceptable quality standards of a CIPP method for the complete rehabilitation of the designated sanitary sewer pipes.

1.03 DESCRIPTION OF SERVICES PROVIDED BY CONTRACTOR

It is the intent of this specification for the Subcontractor to provide for the rehabilitation and repair of certain underground piping ranging in diameter by the trenchless cured-in-place pipe reconstruction method.

- A. The process is defined as the rehabilitation of existing sewer lines by installation of a thermosetting resin impregnated flexible felt fiber tube coated on one side with polyurethane which is installed in the sewer by pulling it into place or by water column inversion. Curing is accomplished by circulating hot water or steam throughout the length of the inverted tube to cure the thermosetting resin into a hard impermeable pipe with the polyurethane coating on the interior surface of the reconstructed pipe. After reconstruction, the "cured-in-place pipe" (CIPP) shall provide flow capacity greater than 100 percent of the original pipe's flow capacity when new. The reconstructed pipe shall extend the full length of the original pipe and shall provide a structurally sound, joint-less, close fitting and corrosion resistant conduit suitable for service in a municipal sanitary sewage environment.
- B. The following work and components shall be provided by the Subcontractor:

09910-1

CITY OF MEMPHIS – STANDARD CONSTRUCTION SPECIFICATION
Modified by SARP10 Program
SECTION 09910 – CURED IN PLACE PIPE (CIPP) INSTALLATION

1. Traffic Control if needed (in accordance with local, state and federal regulations)
2. Pre-Installation Cleaning and CCTV Inspection of Each Pipe Segment (including bypass pumping operations)
3. Insertion and curing of the resin-impregnated tube.
4. Post-Lining Inspection and Testing (see PART 4 – FIELD QUALITY CONTROL of these specifications)
5. Post Rehabilitation CCTV inspection of the Pipe Segment
6. Site Cleanup

1.04 REFERENCED SPECIFICATIONS

This specification references American Society for Testing and Materials (ASTM) standards, which are made part hereof by such reference, and shall be the latest edition and revision thereof. If there is a conflict between those standards and this specification, this specification will govern.

- A. Installation and material tests of cured-in-place pipe (CIPP) must meet the minimum requirements demonstrated in the latest revisions of the following ASTM standards:

ASTM D543 – Standard and Practice for Evaluating the Resistance of Plastics to Chemical Reagents

ASTM D638 – Standard Test Method for Tensile Properties of Plastics

ASTM D790 – Standard Test Method for Flexural Properties of Unreinforced and Reinforced Plastics and Electrical Insulating Materials

ASTM F1216 – Standard Practice for Rehabilitation of Existing Pipelines and Conduits by the Inversion and Curing of a Resin-Impregnated Tube

ASTM F1743 – Standard Practice for Rehabilitation of Existing Pipelines and Conduits by Pulled-in-Place Installation of Cured-in-Place Thermosetting Resin Pipe (CIPP)

ASTM D5813 – Standard Specification for Cured-in-Place Thermosetting Resin Sewer Piping Systems

ASTM D2990 – Standard Test Methods for Tensile, Compressive, and Flexural Creep and Creep-Rupture of Plastics

- B. Any approved process shall strictly adhere to this specification with regard to all standards and requirements. Where discrepancies exist, or any latitude is either inferred or interpreted between this specification and ASTM product and process standards, this Specification shall govern.

1.05 QUALITY ASSURANCE

- A. Acceptable CIPP Manufacturers

CITY OF MEMPHIS – STANDARD CONSTRUCTION SPECIFICATION
Modified by SARP10 Program
SECTION 09910 – CURED IN PLACE PIPE (CIPP) INSTALLATION

Pre-approved resin-impregnated cured-in-place pipe (CIPP) products shall be Insituform® (Insituform Technologies), MooreLiner (Moore Construction), products of Inland Pipe Rehabilitation, LLC (Improved Technologies Group/Texas Repipe), products of Spiniello Companies, SAK Construction LLC, Layne Inliner (Reynolds), A&H Contractors, Inc., Suncoast Infrastructure Inc., Visu-Sewer, or approved equal.

B. MAINLINE CURED IN PLACE PIPE

Any currently approved process or subsequently approved equal shall strictly adhere to this specification with regard to all standards and requirements. Where discrepancies exist between this specification and established manufacturer's product and process specifications, this specification shall govern. All approved manufacturers must submit the qualifying documentation for the specific individuals who will be in charge in the field on this particular project. Any manufacturer which submits a proposal and does not include the information on the specific supervisory personnel who will be installing this job will have its bid disqualified. Any bidder which submits certain individuals for approval cannot then substitute other individuals for the actual construction without written approval of the Program Manager. Failure by the bidder/Subcontractor to meet this stipulation will be cause for termination of any executed contract and disqualification from future bids.

1.06 QUALIFICATIONS

- A. The Subcontractor performing the CIPP lining work shall be experienced and equipped to complete this work expeditiously and in a satisfactory manner, and shall be certified and/or licensed as an installer by the CIPP lining manufacturer.
- B. The Subcontractor shall have successfully installed a minimum of 500,000 feet (total) or 2,000 manhole-to-manhole line sections for the proposed CIPP lining for at least a 5-year continuous period installing CIPP linings in pipe of a similar size, length, and configuration as contained in this Contract as documented by verifiable references.
- C. The full-time, on-site supervisor who will supervise the CIPP lining installation under this Contract shall have successfully installed a minimum of 150,000 feet (total) of the proposed CIPP lining for at least a 3-year period as documented by verifiable references.
- D. The Subcontractors personnel including the supervisor, the foreman, and the lead crew personnel for the CCTV inspection, resin wet-out, the CIPP lining installation, lining curing and the robotic service reconnections each must have a 3-year minimum total experience with the CIPP technology proposed for this Contract, and must have demonstrated competency and experience to perform the scope of work contained in this Contract. The name and experience for each lead individual performing work on this contract shall be submitted. Personnel replaced by the Subcontractor on this contract shall have similar, verifiable experience as the personnel originally submitted for the project.
- E. The Program Manager reserves the right to approve or disapprove the Subcontractor, Supervisor, and/or manufacturer based on the submitted qualifications and a follow-up interview.

1.07 SUBMITTALS

- A. Submit product data, design calculations, installation details, and shop drawings to the Program Manager. The Subcontractor shall provide this information without delay or claim to any confidentiality. Submittals shall include the following and be divided into three sections of qualifications, pre-installation, and post-installation:

CITY OF MEMPHIS – STANDARD CONSTRUCTION SPECIFICATION
Modified by SARP10 Program
SECTION 09910 – CURED IN PLACE PIPE (CIPP) INSTALLATION

1. CIPP lining supplier's name and a materials list
2. CIPP lining schedules including field-verified lengths and diameters for all CIPP linings and appurtenances required. Plans should include map(s) showing insertion points for all CIPP installations.
3. Shop drawings and product data to demonstrate compliance with these specifications and identify construction materials including resins, catalysts, felt, etc., felt manufacturer and facility location, wet-out facility location, etc.
4. Manufacturers' shipping, storage, and handling recommendations for all CIPP system components.
5. MSDS sheets for all materials to be furnished for the project
6. Detailed installation procedures including CIPP lining production schedule, acceptable inversion heads and pressures, inversion procedures, curing and cool-down procedures and temperatures, and times for each process stage
7. Prior to each CIPP lining shipment, certified test reports showing the CIPP lining for this Contract was manufactured and tested in accordance with all ASTM Standards specified and referenced herein.
8. An odor control plan which ensures project specific odors will be minimized at the project site and surrounding area
9. A detailed public notification plan shall be prepared and submitted including detailed staged notification to residences affected by the CIPP installation.
10. A complete description for the proposed wet-out procedure for the proposed technology.
11. Wet-out forms with detailed information including, but not limited to: resin volumes and/or weights, CIPP liner length, roller gap settings, start times, finish times, gel times, resin injection locations, and any other pertinent data documenting the wet-out for each CIPP liner section manufactured.
12. Design data and specification data sheets listing all parameters used in the CIPP liner design and thickness calculations based on ASTM F1216. All calculations shall be prepared under and stamped by a Tennessee registered professional engineer.
13. Manufacturer's recommended cure method for each CIPP liner diameter and thickness to be installed including detailed curing procedures describing the curing medium and the application method.
14. CIPP lining curing log reports documenting the liner installation for all sewer segments. The CIPP lining reports shall document all lining installation details including manhole numbers, street names/sewer location, project number, date, time, temperature, curing temperature, curing time, CIPP liner thickness, etc. A sample report shall be submitted to the Construction Manager for approval prior to installing any CIPP lining.
15. Pre- and post-rehabilitation CCTV inspection data as further defined herein. The pre-rehabilitation CCTV inspection shall be performed in the presence of the Program Manager's Resident Project Representative.
16. Ten reports from projects within the past 2 years from independent testing laboratory for liner materials analysis showing: elasticity modulus as determined by appropriate ASTM standard and flexural stress as determined by appropriate ASTM standard. The lining must be the same resin system and felt tube materials as proposed for this project.
17. Installed liner(s) samples for testing to be performed by an ASTM-certified independent testing laboratory, as described further herein.

CITY OF MEMPHIS – STANDARD CONSTRUCTION SPECIFICATION
Modified by SARP10 Program
SECTION 09910 – CURED IN PLACE PIPE (CIPP) INSTALLATION

18. Data on the maximum allowable stresses and elongation of the tube during installation and the means the Subcontractor will use to monitor stress and elongation.
19. A detailed summary about the proposed quality controls to be performed by the Subcontractor including:
 - a. Proposed procedures for quality control.
 - b. Product sampling and testing method and frequency for product sampling and testing in raw material form and cured product form.
 - c. Inspection forms and guidelines for quality control inspections.
- B. Submit the name and experience for lead personnel including verifiable references, as described in the Qualifications in subsection 1.07.

PART 2 – PRODUCTS

2.01 PATENTS

The bidder must prepare his bid package with the knowledge that it is his responsibility to advise the Program Manager of any patent or copyright infringement associated with this project. The Subcontractor ultimately hired to do this work shall bear responsibility for payment of all royalties and license fees. All costs associated with patent infringement shall be borne by the Subcontractor.

2.02 MATERIALS

- A. The CIPP material shall be fabricated from materials which, when cured, will be suitable for the environment intended, i.e., meeting the chemical resistance requirements from ASTM F1216. The final product must not deteriorate, corrode, or lose structural strength in any manner that will preclude meeting the expected design life.
- B. The finished pipe will be such that when the thermosetting resin cures, the total wall thickness will be a homogeneous and monolithic felt and resin composite matrix that will be chemically resistant to exposure to domestic sewage. When cured, the installed CIPP must allow for sufficient resin to account for migration into the host pipe without adversely affecting the integrity of the CIPP. No encapsulating or containment material layer between the resin saturated felt and the host pipe will be permitted. No annular space will be allowed between the tube and the host pipe.
- C. Pricing for cured-in-place pipe will be based on original as-constructed nominal pipe diameters. It will be the responsibility of the Subcontractor to custom manufacture cured-in-place pipe to conform to pipe diameters other than those listed, due to deterioration or other factors, without additional compensation.

2.03 LINER TUBE

- A. The tube shall consist of one or more layers of absorbent non-woven felt fabric and meet the requirements of ASTM F1216. In the event of a discrepancy between the referenced ASTM requirement and the CITY's Specification as modified by SARP10 Program, the CITY's Specification as modified by SARP10 Program will govern.
- B. The acceptable liner tube shall be constructed under ISO 9002 certified procedures. (Proper certification shall be submitted with the "alternative products application"). At time of manufacture, each lot of liner shall be inspected for defects and tested in accordance

CITY OF MEMPHIS – STANDARD CONSTRUCTION SPECIFICATION
Modified by SARP10 Program
SECTION 09910 – CURED IN PLACE PIPE (CIPP) INSTALLATION

with applicable ASTM and industry standards.

- C. Liner tube manufacturers must be able to certify that a minimum of 1 million linear feet has been installed in cured-in-place pipe applications within the US.
- D. The Subcontractor shall measure the inside diameter of the existing pipelines in the field prior to ordering lining, so the lining can be installed in a tight-fitted condition. The Subcontractor shall verify the lengths in the field prior to ordering and prior to impregnating the tube with resin to ensure the tube will have sufficient length to extend the run's entire length. The CIPP lining's length shall be as deemed necessary by the Subcontractor to effectively carry out inserting and sealing the CIPP lining at the outlet and inlet manholes.
 - 1. The CIPP lining tube shall be manufactured or fabricated to a size that will tightly fit the internal circumference of the sewer being rehabilitated after being installed and cured.
 - 2. The CIPP lining shall be able to fit into irregularly shaped pipe sections and through bends and dips (up to 45 degrees) within the pipeline.
 - 3. Allowance for longitudinal and circumferential expansion shall be taken into account when sizing and installing the CIPP lining.
 - 4. The tube shall be properly sized to the existing pipe's diameter and the length to be rehabilitated, and be able to stretch to fit irregular pipe sections and negotiate bends.
- E. The wet-out tube shall have a uniform thickness that, when compressed at installation pressures, shall meet or exceed design thickness.
- F. The tube shall be manufactured to a size that, when installed, it shall tightly fit the internal circumference and length of the original pipe. Allowances shall be made for circumferential stretching during inversion.
- G. The outside layer of the tube, before installation, shall have an impermeable polyurethane plastic coating, with a roughness coefficient (Manning's "n") no greater than 0.010. This coating shall be an impermeable, flexible membrane that shall contain the resin and facilitate monitoring of resin saturation during the resin impregnation (wet-out) procedure. This coating shall form the inner layer of the finished pipe and is required for enhancement of corrosion resistance, flow and abrasion properties.
- H. At the time of delivery to the jobsite, the tube shall be homogeneous across the entire wall thickness containing no intermediate or encapsulated layers. It shall be uniform in color, free of cracks, holes, blisters, or deleterious faults. No foreign materials may be included in the tube that may cause de-lamination in the cured liner, and no dry or unsaturated areas or layers shall be evident.
- I. The wall color of the interior liner surface after installation shall be a light-reflective color (preferably white) so that a clear, detailed inspection with closed-circuit television equipment may be conducted.
- J. The outside of the tube shall be marked for distance at regular intervals not to exceed 10 feet. Such markings shall include the Manufacturers name or identifying symbol.

CITY OF MEMPHIS – STANDARD CONSTRUCTION SPECIFICATION
Modified by SARP10 Program
SECTION 09910 – CURED IN PLACE PIPE (CIPP) INSTALLATION

- K. The minimum liner length shall be that deemed necessary by the Program Manager to effectively span the distance between manhole sections of the segment to be lined unless otherwise specified. The line lengths shall be verified by the Subcontractor in the field before impregnation of the tube with resin.
- L. Product Handling – Subcontractor shall use all means necessary to protect lining material during transportation, before, during, and after installation and to protect the installed work and materials of all other trades. In the event the liner material is damaged, Subcontractor shall immediately make all repairs or replacements necessary to the approval of the Program Manager, at no additional cost to the Program Manager.

2.04 RESIN

- A. The resin class for CIPP installed under this contract shall be a Standard or Enhanced Polyester unless otherwise directed by the Program Manager due to site-specific field conditions and/or design requirements.

Unless otherwise specified, the Subcontractor shall furnish a resin and catalyst system compatible with the reconstruction process that provides the cured physical strengths specified herein.

- B. Standard Polyester Resin

1. The resin used shall be high-grade corrosion resistant isophthalic polyester specifically designed for the CIPP being installed. Only premium, non-recycled resin shall be used. The acceptable resin, (Reichhold PolyLite® 33420 or approved equal) shall have been tested according to ASTM D2990, D5813, and F1216 by accredited, third-party testing facilities. Results of these tests shall be made available to the Program Manager upon request.
2. The resin must be manufactured under ISO 9002 certified procedures. The resin vendor must be able to reference the corrosion scale with the resin itself having a heat deflection temperature greater than 212 degrees Fahrenheit. Only PREMIUM, NON-RECYCLED resins will be accepted.

- C. Enhanced Polyester Resin

1. The resin used shall be a corrosion resistant enhanced thixotropic, medium reactivity, high viscosity, and rigid, chemical resistant isophthalic resin. These resins contain a mineral filler to enhance mechanical properties and are specifically formulated for use in the cured-in-place pipe (CIPP) industry.
2. The acceptable resin, (Reichhold PolyLite® 33420-E or approved equal) shall have been tested according to ASTM D2990, D 5813 and F 1216 by accredited third party testing facilities. Results of these tests shall be made available to the Program Manager upon request.
3. The resin must be manufactured under ISO 9002 certified procedures. The resin

CITY OF MEMPHIS – STANDARD CONSTRUCTION SPECIFICATION
Modified by SARP10 Program
SECTION 09910 – CURED IN PLACE PIPE (CIPP) INSTALLATION

vendor must be able to reference the corrosion scale with the resin itself having a heat deflection temperature greater than 224 degrees Fahrenheit. Only PREMIUM, NON-RECYCLED resins will be accepted.

D. No Intermediate Mixing Facilities Allowed

The resin shall be shipped directly from the resin manufacturer's facility to the CIPP wet-out facility. The resin shall not be sent to any intermediate mixing facility. Copies of the shipping documents from the resin manufacturer shall be submitted to the Program Manager indicating dates of shipment, originating and receiving locations.

E. Urethane-modified Vinyl Ester Resins (if applicable)

1. The resin used shall be a high-grade, premium vinyl ester combining outstanding corrosion resistance and high-temperature performance with excellent laminating characteristics. The resin must be manufactured under ISO 9002 certified procedures. (Proper certification shall be submitted with the "alternative products application").
2. The resin vendor must be able to reference the heat corrosion scale with the resin itself having a heat deflection temperature greater than 244 degrees Fahrenheit. Only premium, non-recycled resins will be accepted. PET resins or those containing enhancement additives and/or fillers will not be accepted without prior written approval by the PROGRAM MANAGER.

2.06 ADDITIONAL PROVISIONS

In order that the Program Manager is assured that the specified resin is used for the duration of the project, the following provisions are made part of this specification:

- A. The Subcontractor shall designate a wet-out facility and shall provide wet-out liner tubes from the designated facility only. If determined to be absolutely necessary, an alternate wet-out facility may be utilized with the approval of the Program Manager. If an alternate facility is used to supply wet-out liner tubes, the Subcontractor shall provide all necessary documentation to the satisfaction of the Program Manager to ensure compliance with the specifications of this contract.
- B. The Subcontractor shall place a sampling valve in-line at a point in the resin/catalyst mixing stage so that a sample of non-catalyzed resin may be taken. A second sampling valve shall be placed in-line at a point after the resin/catalyst mixing stage, but prior to catalyzed resin injection into the liner so that a resin sample may be taken. Both sampling valves shall be left in place for the duration of the contract.
- C. The Program Manager shall have the right to inspect the designated wet-out facility and draw samples from one or both sampling valves without prior notice to the Subcontractor.
- D. Resins shall be tested as specified by ASTM D5813, and the same frequency as liner samples, and the tests shall be performed by an independent lab and paid for by the

CITY OF MEMPHIS – STANDARD CONSTRUCTION SPECIFICATION
Modified by SARP10 Program
SECTION 09910 – CURED IN PLACE PIPE (CIPP) INSTALLATION

Subcontractor.

- E. The Program Manager may perform Infrared Scans (IR Scans) at its expense to insure resin quality and consistency throughout the project.

2.06 CATALYST SYSTEMS

- A. The exact mixture ratio of resin and catalyst shall also be submitted. The catalyst system shall be identified by product name. The resin/catalyst ratio shall be approved by the resin manufacturer in writing. The catalyst system shall be made up of a primary catalyst and a secondary catalyst. Catalyst shall be compatible with the resin to control resin cure time and also compatible with the reconstruction process that provides cured physical strengths specified herein.
- B. Cure schedules for the CIPP shall be submitted to the Program Manager for review. The proposed curing schedules/process shall be approved by the resin manufacturer in writing. Cure schedules shall include specific information on “step curing” procedures, “cooking times”, duration and “cool down” procedures – all to be approved by the resin manufacturer in writing.
- C. The resin shall be shipped directly from the resin manufacturer’s facility to the CIPP wet-out facility. The resin shall not be sent to any intermediate mixing facility. Copies of the shipping documents from the resin manufacturer shall be submitted to the Program Manager indicating dates of shipment, originating and receiving locations.
- D. The Subcontractor shall submit a Certificate of Authenticity from the resin manufacturer for each shipment to the wet-out facility to include the date of manufacture and Heat Distortion Temperature. This information shall be submitted before the manufacture or installation of any CIPP.

2.07 PIPE DESIGN

- A. Liner Thickness

The Subcontractor shall submit liner thickness calculations to the Program Manager for review. Overall, the hydraulic profile shall be kept as large as possible. The CIPP shall at a minimum have the full flow capacity of the original pipe before rehabilitation. The CIPP shall be designed in accordance with the applicable provisions of ASTM F1216 and D2412 for “partially deteriorated gravity pipe conditions” and shall meet the following design conditions:

1. AASHTO H-20 Live Load with two trucks passing for CIPP in streets (16,000 lbs.)
2. A soil modulus of elasticity of 1,000 psi, soil weight of 120 pounds per cubic foot and a coefficient of friction of $K_u' = 0.13$.
3. Standard Polyester Resin: Short-term flexural modulus of 250,000 psi and long-term modulus of 125,000 psi. Enhanced Polyester Resin: Short-term flexural modulus of 400,000 psi and long-term modulus of 200,000 psi. Initial flexural strength of 4,500 psi and long term flexural strength of 2,250 psi.

CITY OF MEMPHIS – STANDARD CONSTRUCTION SPECIFICATION
Modified by SARP10 Program
SECTION 09910 – CURED IN PLACE PIPE (CIPP) INSTALLATION

4. Safety factor of 2.0 shall be used.
5. Groundwater elevation at the ground surface.
6. Pipe ovality of 2% (unless actual field measurements prove otherwise).
7. Poisson ratio of 0.3.
8. Enhancement factor (K) of 7.
9. Service temperature range shall be 40 to 140 degrees F.
10. Maximum long-term deflection shall be 5%.
11. The installed, cured thickness shall be the largest thickness as calculated for deflection, bending, buckling, minimum stiffness and a 50 year design life.

The Minimum Acceptable Pipe Thickness (**Finished and Installed**), shall be based on design parameters in section 2.07, Items (1) through (11) of this Specification adjusted for site-specific field conditions and approved by the Program Manager prior to tube manufacture.

- B. It is the Subcontractor's responsibility to determine the site specific external loads on the liner and increase or decrease its thickness as required. In the event actual field conditions allow for a deviation in the above thickness table, the Subcontractor shall submit any proposed changes to the Program Manager for approval to ensure installed CIPP meets minimum thickness requirements. The plan shall include detailed inversion procedures to reduce stretching and resin loss and to minimize shrinkage.
- C. The Subcontractor shall submit his price proposal based on the appropriate length, size, and existing pipe parameters. The deterioration of sewers is an on-going process. In the event pre-construction inspections reveal the sewers to be in substantially different conditions than those in the design considerations, the Subcontractor shall request such changes in reconstruction liner thickness, supporting such requests with the appropriate design data satisfactory to the Program Manager. The deviation, if approved, shall be reflected by the appropriate addition or reduction in the unit cost for that size as agreed to by the Program Manager.
- D. Any liner that does not meet the specified strength and/or thickness requirements, regardless of the amount below the specified requirements, shall be corrected by the Subcontractor in a manner approved by the Program Manager at no additional cost to the Program Manager. The Program Manager's decision on how to correct deficient CIPP installations shall be final. Options for correcting deficient liners that will be considered by the Program Manager include removing the liner and re-lining the sewer, excavating and replacing the sewer from manhole to manhole, or providing the Program Manager with a substantial credit. The primary option that will be considered will be to re-line the sewer. Credits will only be authorized for CIPP that does not meet required thickness. If a credit is acceptable to the Program Manager, the credit shall be calculated by multiplying the bid price by the percent that the liner thickness is below the required installed thickness as follows:
- Credit = (1 – Installed CIPP thickness/required CIPP thickness) x bid price**
- E. The Subcontractor shall not assume a credit will be acceptable to the Program Manager in any case.

CITY OF MEMPHIS – STANDARD CONSTRUCTION SPECIFICATION
Modified by SARP10 Program
SECTION 09910 – CURED IN PLACE PIPE (CIPP) INSTALLATION

- F. The finished CIPP will provide a uniform smooth, interior wall surface and will have at least 100% of the flow capacity of the original pipe before rehabilitation.

PART 3 - EXECUTION

3.01 INSTALLATION

A. General

1. All reconstruction of existing gravity sewer mains using an approved CIPP Product and Installer shall be performed in accordance with the latest revision of ASTM F1216.
2. The Subcontractor shall carry out his operations in strict accordance with all applicable OSHA standards. Particular attention is drawn to those safety requirements involving work on an elevated platform and entry into a confined space.
3. All surfaces, which have been damaged by the Subcontractor's operations, shall be restored to a condition at least equal to that in which they were found immediately prior to the beginning of the Subcontractor's operations. Suitable materials and methods shall be used for such restoration. The restoration of existing property or structures shall be done as promptly as practicable and shall not be left until the end of the construction period. Compensation for this work will be included in the rehabilitation item to which it pertains.

B. Installation Procedures

1. Cleaning and Inspections – Sewers shall be cleaned of all debris, roots and other materials that would block proper inversion of the cured-in-place pipe. Inspection of the sewer pipe shall be performed by the Subcontractor's experienced personnel trained in location breaks and obstacles by CCTV inspection and certified under National Association of Sewer Service Companies (NASSCO) Pipeline Assessment Certification Program (PACP[®]). Utilizing a color video inspection system with data recording capabilities, the entire pipe section to be lined shall be inspected in accordance with the CCTV specifications. The interior of the pipe shall be carefully inspected to determine the location of any conditions, which may prevent the proper installation of the CIPP, and it shall be noted so that these conditions can be corrected. The video inspection shall be performed in the presence of the Program Manager's Resident Project Representative. The DVD/CD-ROM and suitable log shall be submitted to the Program Manager with database and reports in a PACP compliant format to be incorporated into the Program Manager's computer management system and GIS.
2. Utilizing high-pressure jet cleaning equipment, several passes are completed to assure that all debris is removed from the pipe. If roots are present, root cutters or mechanical brushes are attached to the jet nozzle and sent through the line to remove all root intrusions. Should equipment other than that described above be

CITY OF MEMPHIS – STANDARD CONSTRUCTION SPECIFICATION
Modified by SARP10 Program
SECTION 09910 – CURED IN PLACE PIPE (CIPP) INSTALLATION

needed to remove debris or heavy roots, additional payment may be authorized by the Program Manager.

3. Heavy Cleaning of Sewers – If roots are present which require the use of mechanical brushes or dragging devices or, if in the judgment of the Program Manager, the pipe is more than 25% full of debris, the pipe shall be cleaned to the satisfaction of the Program Manager and additional payment authorized under the appropriate Pay Item on the bid form. Heavy Cleaning shall be defined as the pipe being more than 25% full of debris or requiring the use of apparatus other than normal high-pressure jetting equipment. The Subcontractor shall be paid for heavy cleaning at the contract unit price shown on the bid form. Any heavy cleaning shall be supported by visual evidence in the form of video or digital image and must be pre-approved by the Program Manager.
4. If the CIPP lining manufacturer believes the infiltration rate in the sewer segment is high enough to risk washing out the resin, the Subcontractor shall perform required measures to minimize infiltration prior to installation. If any infiltration runners or gushers are observed during the pre-CCTV inspection, the Subcontractor shall submit, in writing for approval by the Construction Manager, the methods and materials for mitigating any adverse impacts from the infiltration.
5. Resin Impregnation of the CIPP Tube – The Subcontractor shall designate a location where the tube shall be impregnated or “wet out” with resin, using distribution rollers and a “single-source” or “serial” vacuum system to thoroughly saturate the tube’s felt fiber prior to installation in the field. The impregnated tube shall be free of pinholes, resin voids and other defects and sufficient excess resin shall be provided to allow for resin migration into the host pipe. If the cured-in-place pipe is impregnated at the manufacturing plant, it shall be delivered to the job site packed in ice in a refrigerated truck, and remain refrigerated prior to installation to prevent premature curing. If an “over the hole” or remote wet out is proposed, installation and wet out procedures shall be submitted in detail and must be approved by Program Manager prior to installation.
6. Inversion of CIPP Liner Tube – Installation shall be carried out in accordance with this Specification only. The impregnated tube shall be water inverted through an existing manhole or other approved access point utilizing a hydrostatic water column or pressurized steam until it has fully traversed the designated line length and the inversion face breaches the destination manhole or termination point. The fluid column or air pressure shall have been adjusted and maintained to be sufficient to cause the impregnated tube to hold tight against the existing pipe wall, produce dimples at side connections, and flared ends at the manholes. Lubricant during inversion shall be used as necessary in accordance with the CIPP manufacturer’s recommendations. Thermocouples shall be placed at the top and bottom interface of both ends of the liner for monitoring temperature during the cure cycle. Temperature monitoring systems shall be Zia systems or Vericure by Pipeline Renewal Technologies. Care should be taken during tube installation not to over-stress the fabric fiber.

CITY OF MEMPHIS – STANDARD CONSTRUCTION SPECIFICATION
Modified by SARP10 Program
SECTION 09910 – CURED IN PLACE PIPE (CIPP) INSTALLATION

- a. The CIPP lining for 6-inch through 18-inch sewers without sags greater than 30% may be installed via inversion using hydrostatic head or air pressure or pull-in methods in accordance with ASTM F1216 and manufacturer's recommendations.
 - b. The CIPP lining for greater than 18-inch sewers or with sags greater than 30% (depth of water in the pipe) shall be installed via inversion using hydrostatic head in accordance with ASTM F1216 and manufacturer's recommendations.
7. When using pressurized air, particular attention should be given to the maintenance of the minimum required "finished and installed" thickness of the CIPP. Before the inversion begins, the tube manufacturer shall provide the minimum air pressure required to hold the tube tight against the host pipe and the maximum allowable pressure so as not to damage the tube. Once the inversion has started, pressure shall be maintained between the minimum and maximum pressures until the inversion has been accomplished.
8. The preferred method of installation for CIPP shall be inversion using a hydrostatic head (water column). The use of pressurized air will be considered on a case-by-case basis only. The Subcontractor shall submit a written request for the use of pressurized air in sewer segments where the Subcontractor feels that the utilization of pressurized air will be beneficial to the Program Manager. The Subcontractor shall not assume in any case that the use of pressurized air is acceptable to the Program Manager without prior written authorization from the Program Manager.
9. Setup bypass pumping, if necessary, or turn off water to building with Engineer's approval.
- C. Manhole Modification for CIPP Installation
1. If the Subcontractor deems it necessary to temporarily modify a manhole for CIPP installation, he shall submit a drawing detailing the modification. The drawing must be stamped by a licensed Professional Engineer in the State of Tennessee and approved by the Purchaser prior to modification.

3.02 CURING

- A. *Initial cure* will occur during temperature heat-up and is completed when exposed portions of the new pipe appear to be hard and sound and the thermocouples indicate that the temperature is of a magnitude to realize an exothermic reaction or cure in the resin. After initial cure is reached, the temperature shall be raised to the post-cure temperature recommended by the resin manufacturer. Post-Cure temperature shall be held for a period as recommended by the resin manufacturer, during which time the recirculation of the water and cycling of the heat source to maintain the temperature continues.

CITY OF MEMPHIS – STANDARD CONSTRUCTION SPECIFICATION
Modified by SARP10 Program
SECTION 09910 – CURED IN PLACE PIPE (CIPP) INSTALLATION

Prior to any inversion, the Subcontractor shall provide a *Post-Cure Hold Time and Temperature Table*. This table shall indicate the minimum time and temperature the inverted tube will be held at in order to achieve desired physical properties. The resin manufacturer shall certify both the time and temperatures presented in the table.

Curing must take into account the existing pipe material, the resin system, and the ground conditions (temperature, moisture level, and thermal conductivity of the soil).

1. Using Circulated Heated Water

- a. A suitable heat source and water recirculation equipment is required to circulate heated water throughout the pipe. The equipment shall be capable of delivering hot water throughout the inverted tube to uniformly raise the temperature required to cause a cure of the resin.

2. Using Controlled Steam

- a. Suitable steam-generating equipment is required to distribute steam throughout the pipe. The equipment shall be capable of delivering steam throughout the inverted tube to uniformly raise the temperature required to cause a cure of the resin.
- b. The Time and Temperature Table submitted when using steam curing shall be identical to time and temperature hold times when curing with heated, circulated water.

- B. The preferred method of curing CIPP shall be by circulated water. The use of controlled steam will be considered on a case-by-case basis only. The Subcontractor shall submit a written request for the use of steam in sewer segments where the Subcontractor feels that curing by steam will be beneficial to the finished product. The Subcontractor shall not assume in any case that the use of controlled steam for the curing of CIPP is acceptable to the Program Manager without prior written authorization from the Program Manager.

3.03 POST CURING

- A. CIPP Processing (Curing and Cool Down) - The cure cycle and cool down will be dictated with consideration given to actual field conditions and shall be according to the manufacturer's recommendations. The curing temperatures shall be monitored at the heater truck's water inlet and outlet lines. The temperature readings from the truck will be compared to the thermocouples to insure that sufficient heat is being supplied to the system to affect proper cure. Once the pipe has been cured, cool water shall be slowly introduced into the rehabilitated pipe. The water temperature shall be cooled inside of the pipe at a rate of 20 to 30 degrees per hour until the water temperature is within 20 degrees of the ambient temperature. The cool down process will also be affected by actual field conditions and may be modified in cases of severe conditions or below normal ground temperatures.

- B. Temperature monitoring systems shall be required for all 18-inch or larger sewers, any

CITY OF MEMPHIS – STANDARD CONSTRUCTION SPECIFICATION
Modified by SARP10 Program
SECTION 09910 – CURED IN PLACE PIPE (CIPP) INSTALLATION

sized sewer that crosses a stream, creek, or other body of water, or as noted on the Drawings. This system shall be installed at the pipe invert per the manufacturer's recommended procedures. The temperature sensors shall be placed at intervals as recommended by the sensor manufacturer. Additional sensors shall be placed where significant heat sinks are likely or anticipated. The sensors, if installed, shall be monitored by a computer using a tamper-proof database which can record temperatures at the lining interface and the host pipe. Temperature monitoring systems shall be Zia systems or Vericure by Pipeline Renewal Technologies.

- C. Termination and Sealing at Manhole Outlets – The Subcontractor shall install a hydrophilic seal at each manhole face prior to inverting or pulling in the uncured CIPP lining. These seals should be per Hydrotite by Greenstreak, Insignia by LMK, or an approved equal.

All CIPP lining cutting and sealing at manhole connections shall provide watertight pipe and manhole seals. All cured lining cut edges shall be thoroughly sealed with the same resin as used in the lining. The catalyst or hardener used shall be compatible with the resin/catalyst previously used in the lining, but shall not require an external heat source to begin the exothermic reaction (curing).

- D. Testing - testing of finished CIPP and leakage testing of the finished CIPP-lined sewer mains shall be conducted prior to the reinstatement of laterals in the presence of the Program Manager, and shall follow Part 4 of these specifications.

3.04 CLEAN UP

- A. Upon acceptance of any installation by the Program Manager, the Subcontractor shall reinstate the project area affected by his operations to a condition at least equal to that existing prior to the work. The Subcontractor shall flush and clean each newly lined section, if necessary, to remove all accumulated debris, rocks, gravel, sand, silt and other foreign material from the system at or near the closest downstream manhole. Debris shall not be allowed to pass downstream. If it does, the Subcontractor shall clean the next segment at no additional cost.

3.05 BYPASS PUMPING

- A. As required for acceptable completion of the work and/or to avoid damages due to sewer spills or overflows, the Subcontractor shall provide for sewer flow maintenance around the line segments and manholes designated for rehabilitation. The bypass shall typically be made by plugging the line at an existing upstream manhole and pumping the flow into a downstream manhole or adjacent sanitary sewer system. The pump and bypass lines shall be of adequate capacity and size to handle the anticipated flow. Bypassing of sanitary sewage into the storm water system will not be allowed. For all bypass pumping, pump noise shall be kept to a minimum to the satisfaction of the Program Manager. The Subcontractor shall be required to contact all residential and commercial customers whose service lines connect to the sewer main being bypassed and inform them that they will be temporarily out of service. The Subcontractor shall also advise those customers

CITY OF MEMPHIS – STANDARD CONSTRUCTION SPECIFICATION
Modified by SARP10 Program
SECTION 09910 – CURED IN PLACE PIPE (CIPP) INSTALLATION

against water usage until the mainline is back in service. After completing the necessary work on the main line, the Subcontractor shall advise those customers that the sewer main is back in service.

- B. Bypass pumping is defined as providing pumps, standby pumps, piping, elevated structural support for aerial crossings, manpower to operate, routine maintenance and repair capability, pipe plugs, fuel, route and pump site clearing and any other work necessary to provide a complete bypass pumping operation. Any structures proposed by the Subcontractor for construction over or penetration into the interceptor piping for the purpose of performing the bypass operations must be approved by the Program Manager prior to implementation. The Subcontractor shall submit design drawings and details that are signed and sealed by a professional engineer licensed in the State of Tennessee. All bypass pump schemes must be submitted to and approved by the Program Manager in advance.

PART 4 - FIELD QUALITY CONTROL

4.01 SAMPLE PREPARATION AND TESTING OF CURED CIPP

Sample preparation, sample testing, and leakage testing of the finished CIPP-lined sewer mains shall be performed in accordance with this specification. The Subcontractor shall furnish all equipment and personnel necessary to conduct these preparations and tests.

- A. The Subcontractor shall prepare CIPP samples for each inversion according to this Specification and ASTM F-1216. The Program Manager may, at its discretion, submit samples of the cured CIPP for laboratory determination of flexural strength, flexural modulus and wall thickness for each test sample during the execution of this Contract. These three individual analyses shall comprise one completed test. All samples shall be collected per the sampling protocols set forth in ASTM F-1216.
- B. The Subcontractor shall prepare one restrained sample of the installed liner at least 12 inches in length for testing. For sewers 15 inches and larger, plate samples may be taken and cured in the same manner as the installed CIPP. For each sample taken, the Subcontractor shall cut and deliver a 1-inch wide representative sample (taken at least 2 inches from the end of the specimen) to the Program Manager. The sample delivered to the Program Manager shall be labeled and removed from any restraining mold. The Program Manager may return such samples to the Subcontractor for disposal.
- C. The tests shall be used to verify that the installed CIPP meets these specifications. CIPP thickness shall be measured in accordance with ASTM D5813. Flexural properties shall be determined per ASTM D790. The Subcontractor shall label and date all samples and deliver the samples directly to the Program Manager. All testing shall be performed by an independent, ASTM-certified testing laboratory of the PROGRAM MANAGER's designation and at the Program Manager's expense. Payment to the Subcontractor shall be withheld pending the Program Manager's acceptance of the CIPP test results.
- D. Any liner that does not meet the specified strength and/or thickness requirements, regardless of the amount below the specified requirements, shall be corrected by the Subcontractor in a manner approved by the Program Manager at no additional cost to the

CITY OF MEMPHIS – STANDARD CONSTRUCTION SPECIFICATION
Modified by SARP10 Program
SECTION 09910 – CURED IN PLACE PIPE (CIPP) INSTALLATION

Program Manager. The Program Manager's decision on how to correct deficient CIPP installations shall be final.

4.02 EXFILTRATION TESTING OF CIPP SEWER MAINS

- A. Leakage testing of all finished CIPP lined sewer mains shall be conducted prior to the reinstatement of laterals in the presence of the Program Manager in accordance with the exfiltration test method for gravity pipes described in the latest revision of ASTM F1216 unless revised herein. The Contractor shall furnish all equipment and personnel necessary to conduct all of the leakage tests. If, in the judgement of the Program Manager, any unsatisfactory conditions are present, the Subcontractor shall correct conditions in these areas at no additional cost to the Program Manager.

4.03 FINAL VIDEO INSPECTION

- A. CCTV in accordance with Section 00004 shall be submitted after liner installation. This inspection shall be performed, one section at a time, by a color video inspection system. The finished CIPP shall be continuous over the entire length of all inversion runs and be free of dry spots, wrinkles, pinholes, holidays, lifts, and delaminations. The camera's rate of travel shall not exceed 20 feet per minute. The footage meter count shall be clearly visible. Logs shall include date, line size, length, manhole numbers and project number, direction of camera travel, direction of flow, and any observed defects or comments. Videos between manhole segments shall be continuous; no breaks or "blink-outs" in the video shall be observed. No infiltration of groundwater shall be observed. All service entrances shall be accounted for and shall be unobstructed including all rehabilitated service lateral connection repair(s). If, in the judgment of the Program Manager, any unsatisfactory conditions are present, the Subcontractor shall correct conditions in these areas at no additional cost to the Program Manager.

PART 5 - SUBCONTRACTOR RESPONSIBILITIES

5.01 PROTECTION OF DOWNSTREAM FACILITIES

The Subcontractor must take all steps necessary to assure that no material is allowed to fall into the line during his installation process. The Subcontractor shall bear all cost of repairs resulting from any damages to downstream facilities resulting from failure to abide by this stipulation.

5.02 WASTEWATER SPILLS

- A. Should the Subcontractor spill any wastewater, such that the sewage either immediately or ultimately enters the waters of the State of Tennessee, then the Subcontractor will be completely responsible for any fines or penalties imposed on the Program Manager or the Subcontractor by the USEPA or the State of Tennessee.
- B. Public advisory services will be required to notify all parties whose service laterals will be out of service and to advise against water usage until the mainline is back in service.

CITY OF MEMPHIS – STANDARD CONSTRUCTION SPECIFICATION
Modified by SARP10 Program
SECTION 09910 – CURED IN PLACE PIPE (CIPP) INSTALLATION

- C. The Subcontractor will be required to provide businesses with temporary service, as needed, and will be responsible for all necessary bypass pumping flows.

5.03 WATER

The Subcontractor will be required to Contact Memphis Light, Gas, & Water (MLGW) located at 3941 Grandview Avenue (telephone: 901-320-3910) in order to acquire a water meter for the lining process. Any water costs associated with the lining process will be considered incidental to the contract and not a separate pay item. Water for all construction operations shall be available from identified MLGW fire hydrants at normal commercial rates. Water usage shall be in accordance with MLGW's backflow and metering policies.

5.04 SAFETY

- A. The Subcontractor shall carry out his operations in strict accordance with all applicable OSHA and SARP10 standards. Particular attention is drawn to those safety requirements involving work on an elevated platform and entry into a confined space.
- B. The Subcontractor will be responsible for locating and accessing all manholes, or other structures associated with the pipe system to be lined. The Program Manager will provide personnel to guide the Subcontractor to the locations but will not provide additional access.

5.05 SITE RESTORATION

- A. The Subcontractor shall restore or replace all removed or damaged paving, curbing, sidewalks, gutters, shrubbery, fences, sod or other disturbed surfaces or structures to a condition equal to that before the work began, to the satisfaction of the Program Manager, and shall furnish all labor and material incidental thereto.
- B. The restoration of existing property or structures shall be done as promptly as practicable and shall not be left until the end of the contract period. Compensation for this work will be included in the rehabilitation item to which it pertains.

5.06 PUBLIC NOTIFICATION

- A. Public

Prior to conducting CIPP field work, the Subcontractor shall provide notification to every residence and business that may be affected. The Subcontractor shall distribute the Program Manager approved door hangers between 48 and 72 hours prior to the start of the CIPP effort. Door hangers shall be double-sided with the notification information in the English language on one side and in the Spanish language on the reverse side. The local fire department shall be notified of the smoke testing at least seven days in advance.

At a minimum, the notifications shall advise residents of what to expect during the lining process, and the Subcontractor shall notify utility customers 48 hours in advance of disconnecting sewer services if the service will be offline for more than eight (8) hours.

Door hanger notifications shall use a fluorescent color for visibility and incorporate any SARP10-specific mascot or logo (if available and agreed upon by the Program Manager)

CITY OF MEMPHIS – STANDARD CONSTRUCTION SPECIFICATION
Modified by SARP10 Program
SECTION 09910 – CURED IN PLACE PIPE (CIPP) INSTALLATION

to link the CIPP work to the Program Manager's sewer improvement effort.

B. Program Manager

The Subcontractor shall provide daily morning updates prior to beginning daily field operations to the Program Manager, fire, police, or other agencies as directed by the Program Manager. List of entities and individuals requiring notification will be distributed prior to work commencing.

5.07 WARRANTY

The warranty period shall be for a period of five (10) years from the installation date of the tube. Any defects, which in the opinion of the Program Manager, will affect the integrity or strength of the pipe shall be repaired at the Subcontractor's expense in a manner acceptable to the Program Manager. The material shall be unconditionally guaranteed to meet or exceed the design criteria detailed in this Specification.

PART 6 – MEASUREMENT

6.01 CURED-IN-PLACE-PIPE

A. Cured-In-Place-Pipe will be measured by the linear foot as measured by the final inspection video. The line lengths and quantities shown on the Bid Form are to provide a value for cost extension purposes and are approximate. The Subcontractor will be paid for actual quantities installed in the field. Documented lengths shall be the distance from the upstream inside face of manhole to the downstream inside face of manhole or similar structure. All lengths will be verified by the Program Manager. Diameters will be based on the original as-constructed nominal pipe diameter. Light Cleaning is to be included in the individual line bids.

6.02 BYPASS PUMPING

A. Bypass pumping shall be measured as a lump sum for the CIPP and associated manholes being rehabilitated.

6.03 MANHOLE MODIFICATION

A. Manhole modification will be measured in an each manhole modified.

PART 7 – PAYMENT

7.01 CURED-IN-PLACE-PIPE

A. The accepted quantities of CIPP will be paid for at the contract extended unit price per linear foot, based upon the verified liner diameter and thickness. The price paid per linear foot for pipe lining shall include full compensation for furnishing labor, materials, tools, equipment, and incidentals necessary to furnish, install, and test the CIPP lining, plus manhole connections, preconstruction inspection, cleaning, sewer cleaning materials disposal, final inspection, post-construction inspection, protecting existing utilities and adjacent property,

CITY OF MEMPHIS – STANDARD CONSTRUCTION SPECIFICATION
Modified by SARP10 Program
SECTION 09910 – CURED IN PLACE PIPE (CIPP) INSTALLATION

and all required surface restoration work, complete in place, as shown on the Drawings and specified herein.

7.02 BYPASS PUMPING

A. Bypass pumping will be paid as a lump sum for the CIPP and associated manholes. This item includes all materials and labor necessary to properly comply with the bypass pumping requirements listed in the specification.

7.03 MANHOLE MODIFICATION

A. Manhole modification will be paid on an each basis.

7.04 PAYMENT WILL BE MADE UNDER:

Item No.	Pay Item	Pay Unit
09910-7.01.1	CIPP 96-INCH Diameter	Linear Foot
09910-7.02.1	Bypass Pumping for CIPP and Associated Manholes	Lump Sum
09910-7.03	Manhole Modification	EA

END OF SECTION 9910

CITY OF MEMPHIS – STANDARD CONSTRUCTION SPECIFICATIONS
Modified By SARP10 Program
SECTION 09920 – INTERCEPTOR COATING

PART 1 – SCOPE

1.01 This work consists of the rehabilitation of an interceptor for the sanitary sewer system as shown on the Plans, stipulated in the Contract Documents, or as directed by the Purchaser. The construction will be accomplished by these Specifications and in conformity with the details shown on the Plans or established by the Purchaser. The Subcontractor shall perform all work necessary to complete the Contract with the best modern practice. Unless otherwise provided, the Subcontractor is required to furnish all labor, materials, equipment, and incidentals required to rehabilitate or repair interceptor as noted on the Drawings or directed by the Purchaser.

1.02 Accurately field measure and size each individual interceptor. Each existing sewer interceptor designated to be rehabilitated may have a different configuration and varying field dimensions.

1.03 Each interceptor to be rehabilitated shall be thoroughly cleaned and then inspected for loose or missing bricks, loose mortar, holes, etc. All leaks shall be plugged prior to interceptor rehabilitation.

1.04 The presence or absence of leakage through interceptor walls noted on the interceptor inspection reports and as seen in the Subcontractor's independent interceptor inspections prior to bidding or construction depend on the groundwater levels and conditions at the time of the inspections. High groundwater levels in the project area typically occur in the dormant season (December through May), but will vary with rainfall in any given year and sewer location. Be advised the groundwater currently entering the leaking sewer mains and laterals may migrate to the interceptors after the sewer mains and laterals are rehabilitated or replaced. Reflect assumptions and judgments on leakage through interceptor walls based on this information in the unit prices bid for lining interceptors. All leakage shall be stopped prior to lining interceptors. No additional payment will be made for repairing leaks not visible prior to bidding or sewer rehabilitation.

1.05 Where existing interceptors are being rehabilitated, the Subcontractor will arrange his work so that sewage flow will be maintained during the construction period with no discharge of sewage into the open trench, and no backup of sewage into the existing line. The subcontractor will provide necessary bypass pumping capacity to carry flow downstream of the interceptor to be rehabilitated.

1.06 Definitions/Standards:

ASTM D-638: Test Method for Tensile Properties of Plastics.

ASTM D-695: Test Method for Compressive Properties of Rigid Plastics.

ASTM D-790: Test Methods for Flexural Properties of Unreinforced and Reinforced Plastics and Electrical Insulating Materials.

ASTM D-4541: Standard Test Method for Pull-Off Strength of Coatings Using Portable Adhesion Testers

ASTM D-412: Standard Test Methods for Vulcanized Rubber and Thermoplastic Elastomers—Tension

ASTM D-2240: Standard Test Method for Rubber Property Durometer Hardness

ASTM D-522: Standard Test Methods for Mandrel Bend Test of Attached Organic Coatings

1.07 Quality Assurance. Furnish materials of quality required by the American Society for Testing and Materials (ASTM) standards and industry approved standards and specifications. Provide guarantee against defective materials and workmanship in accordance with the requirements of these specifications.

1.08 Sequencing: All required interruptions of flow through interceptors or any other portion of the sanitary sewer system shall be coordinated with the Owner, and approval must be received from the Owner prior to the interruption.

CITY OF MEMPHIS – STANDARD CONSTRUCTION SPECIFICATIONS
Modified By SARP10 Program
SECTION 09920 – INTERCEPTOR COATING

1.09 When rehabilitating interceptors, the material for stopping active leaks and repairing non-leaking holes, cracks, etc. in concrete and masonry interceptors shall be compatible with the coating system used for rehabilitation.

1.10 Substitutions: Should the Subcontractor wish to use any brand or type of material other than as specified herein, he shall so state in writing to the Purchaser naming the proposed substitution and manufacturer. This statement shall be accompanied by a certificate of compliance from an approved independent testing laboratory that the proposed substitute meets or exceeds the specified requirements and has been tested in accordance with the specified test standards. The statement shall also include documented proof that the proposed brand or type of material has a proven record of performance when used in the intended application as confirmed by actual field test or successful installations.

1.11 The Subcontractor shall apply the interceptor coating system material on a sample area not less than four square feet (4 ft²) in size. When approved, the sample area shall serve as a standard of acceptance for all further work.

1.12 All interceptors shall be coated in their entirety.

PART 2 - MATERIALS AND EQUIPMENT

2.01 MATERIALS

A. Submittals

1. Unless otherwise specified all sample submittals shall be delivered to the Purchaser within two weeks of the NTP.
2. Site Subcontractor emergency phone numbers.
3. Schedules of work on a weekly basis that will be delivered no later than 2:00 PM on Thursday for the week following with daily AM email updates of approximate crew locations each day. Weekly schedule format shall contain a map, with sufficient streets labeled and identified at a scale to provide clarity, along with the nature and type of crew located by map area.
4. Product Data on the following:
 - Crack and hole repair products.
 - Cementitious plug material.
 - Corrosion resistant coating system including application requirements and chemical resistance data.
 - Gasket Polymer Properties
5. Manufacturer's Certificate of Compliance for each type of product that product furnished meets requirements of this Section.
6. Manufacturer's written recommendations for product handling and installation.
7. Confined space entry plans.
8. Plan for diversion of flow during installation of interceptor coating.
9. Subcontractor shall submit to the Purchaser (when requested) evidence indicating that the proposed applicators are fully qualified to perform the work, and any proposed

CITY OF MEMPHIS – STANDARD CONSTRUCTION SPECIFICATIONS
Modified By SARP10 Program
SECTION 09920 – INTERCEPTOR COATING

applicator found to be not qualified shall (at the written request of the Purchaser) be removed forthwith by the Subcontractor.

10. The COATINGS MANUFACTURER shall warranty the entire project to include any and all aspects of the surface preparation, base material installation and protective coating applications for a period of FIVE (10) YEARS from the date of acceptance by the Purchaser. The warranty shall make no distinction between installation practices and material performance and shall not be prorated with respect to elapsed time for the entire warranty period. Manufacturer shall, within a reasonable period of time after receipt of written notice thereof by the Purchaser [period not to exceed sixty (60) calendar days], repair defects in materials or workmanship during said FIVE (10) year period, and any damage to other work caused by such defects or repairing of same at his own expense and without cost to the Purchaser.

B. Interceptor Coating System. Spray applied or centrifugally cast interceptor coating system:

1. The material applied onto the surface of the interceptors shall be a coating system consisting of a base coat and top coat to provide corrosion resistance within a sanitary sewer environment. The thickness of the base coat and top coat shall meet the manufacturer's recommendation. Subcontractor can request to not use a base coat but must provide to the Owner and Purchaser evidence of successful installations of the product without using a base coat and its capability to properly adhere to the interceptor wall and form a smooth finish on the wall.

2. The top coat applied shall be an approved polymer based polyurethane, a geopolymer, or a high-build solvent free epoxy product in conjunction with a high-strength cementitious repair/patch/base coat. The following products are acceptable and approved: Spectrashield Liner Systems, Quadex QM-1s and Structure Guard, GeoKrete Geopolymer by Quadex, EcoCast by IPR, 4553 Epoxy Coating and Maximum CA Plus Cement by Standard Cement.

3. The installer shall warrant and save harmless the Owner and his Purchaser against all claims for patent infringement and any loss thereof. The Subcontractor shall handle and store all material and shall dispose of all wastes in accordance with applicable regulations.

4. Each system shall be designed for application over damp (but not active running water) surfaces without degradation of the final product and the bond between the product and the interceptor surfaces. Active leaks shall be stopped using a premixed fast-setting, volume-stable waterproof cement plug consisting of hydraulic cement, graded silica aggregates, special plasticizing and accelerating agents. It shall not contain chlorides, gypsum, plasters, iron particles, aluminum powder or gas-forming agents, or promote corrosion of steel it may come in contact with. Set time shall be approximately 1 minute. Ten-minute compressive strength shall be approximately 500 PSI.

C. Mortar

1. Mortar shall be composed of one part Portland cement and two parts sand (volumetric measure) thoroughly mixed in a tight box, with water added gradually and mixed continually until mortar has attained the proper consistency for use in brick masonry; prepared only in such quantities as needed for immediate use; mortar mixed for more than 30 minutes, re-tempered, or previously set will not be allowed.

CITY OF MEMPHIS – STANDARD CONSTRUCTION SPECIFICATIONS
Modified By SARP10 Program
SECTION 09920 – INTERCEPTOR COATING

2.02 EQUIPMENT

A. The Subcontractor will furnish and maintain in good condition all equipment and facilities as required for the proper execution and inspection of the Work. All equipment and facilities will be on site and approved by the Purchaser before work will be permitted to begin.

PART 3 – CONSTRUCTION REQUIREMENTS

3.01 PRELIMINARY AND GENERAL ITEMS

A. Traffic Control

1. All traffic control shall be installed and maintained in accordance with the Manual on Uniform Traffic Control Devices (MUTCD). On roads with heavy traffic volume, a flagman may also be needed to assist with traffic control.

B. Fall Protection

1. Subcontractor shall install and maintain all fall protection measures in accordance with the SARP10 Loss Control Manual. The Subcontractor shall construct a controlled access zone around the interceptor being adjusted. At a minimum, the fall protection zone shall include traffic cones encircled with pennant tape. The controlled access zone must have one point of access with an entrance log.

C. Cleaning

1. Sewers shall be cleaned of all debris, roots and other materials that would block proper installation of coating. Inspection of the sewer pipe shall be performed by the Subcontractor's experienced personnel trained in location breaks and obstacles by CCTV inspection and certified under National Association of Sewer Service Companies (NASSCO) Pipeline Assessment Certification Program (PACP[®]). Utilizing a color video inspection system with data recording capabilities, the entire pipe section to be lined shall be inspected in accordance with the CCTV specifications. The interior of the pipe shall be carefully inspected to determine the location of any conditions, which may prevent the proper installation of the coating, and it shall be noted so that these conditions can be corrected. The video inspection shall be performed in the presence of the Purchaser's Resident Project Representative.

2. Utilizing high-pressure jet cleaning equipment, several passes shall be completed to assure that all debris is removed from the pipe. If roots are present, root cutters or mechanical brushes shall be attached to the jet nozzle and sent through the line to remove all root intrusions. Should equipment other than that described above be needed to remove debris or heavy roots, additional payment may be authorized by the Purchaser.

D. Flow Control:

CITY OF MEMPHIS – STANDARD CONSTRUCTION SPECIFICATIONS
Modified By SARP10 Program
SECTION 09920 – INTERCEPTOR COATING

1. The Subcontractor shall be responsible for plugging or diverting the flow of sewage as needed for repair and coating of interceptor.

E. Bypass of Flow:

1. As required for acceptable completion of the work and/or to avoid damages due to sewer spills or overflows, the Subcontractor shall provide for sewer flow maintenance around the interceptors designated for rehabilitation. The bypass shall typically be made by plugging the line at an existing upstream interceptor and pumping the flow into a downstream interceptor or adjacent sanitary sewer system. The pump and bypass lines shall be of adequate capacity and size to handle the anticipated flow. Bypassing of sanitary sewage into the storm water system will not be allowed. For all bypass pumping, pump noise shall be kept to a minimum to the satisfaction of the Purchaser. The Subcontractor shall be required to contact all residential and commercial customers whose service lines connect to the sewer main being bypassed and inform them that they will be temporarily out of service. The Subcontractor shall also advise those customers against water usage until the mainline is back in service. After completing the necessary work on the main line, the Subcontractor shall advise those customers that the sewer main is back in service.

2. Bypass pumping is defined as providing pumps, standby pumps, piping, elevated structural support for aerial crossings, manpower to operate, routine maintenance and repair capability, pipe plugs, fuel, route and pump site clearing and any other work necessary to provide a complete bypass pumping operation. Any structures proposed by the Subcontractor for construction over or penetration into the interceptor piping for the purpose of performing the bypass operations must be approved by the Purchaser prior to implementation. The Subcontractor shall submit design drawings and details that are signed and sealed by a professional engineer licensed in the State of Tennessee. All bypass pump schemes must be submitted to and approved by the Purchaser in advance.

F. Wastewater Spills

1. Should the Subcontractor spill any wastewater, such that the sewage either immediately or ultimately enters the waters of the State of Tennessee, then the Subcontractor will be completely responsible for any fines or penalties imposed on the Purchaser or the Subcontractor by the USEPA or the State of Tennessee.

2. Public advisory services will be required to notify all parties whose service laterals will be out of service and to advise against water usage until the mainline is back in service.

3. The Subcontractor will be required to provide businesses with temporary service, as needed, and will be responsible for all necessary bypass pumping flows.

G. Safety

1. The Subcontractor shall carry out his operations in strict accordance with all applicable OSHA and SARP10 standards. Particular attention is drawn to those safety requirements involving work on an elevated platform and entry into a confined space.

CITY OF MEMPHIS – STANDARD CONSTRUCTION SPECIFICATIONS
Modified By SARP10 Program
SECTION 09920 – INTERCEPTOR COATING

- A. The surface prior to spraying shall be damp without noticeable water droplets or running water. Materials shall be spray applied to a minimum uniform thickness to ensure that all cracks, crevices, and voids are filled and a smooth surface remains after light troweling. Perform light troweling to compact the material into voids and to set the bond.
- B. Application procedures shall conform to the recommendations of the protective coating manufacturer, including handling, thickness, mixing, environmental controls during application, safety, and spray equipment.
- C. The equipment shall be specifically designed to accurately ratio and apply the base coat and top coat materials and shall be well maintained and in proper working order for the duration of the Work.
- D. The coating must be applied by a “Certified Applicator” of the protective coating manufacturer.
- E. Specified surfaces shall be coated by moisture tolerant, solvent-free, protective coating exhibiting properties described in these specifications.
- F. Equipment approved by the coating manufacturer shall be used to apply each coat of the protective coating.
- G. If necessary, subsequent top-coating or additional coats of the protective coating shall occur as soon as the base coat becomes tack-free, ideally within twelve (12) hours but not later than the recoat window for the specified products. Additional surface preparation procedures shall be required if the recoat window is exceeded.
- H. No application shall be made to frozen surfaces or if freezing is expected to occur within the interceptor for 24 hours after application. If ambient temperatures are in excess of 95°F, precautions shall be taken to keep the mix temperature at time of application below 90°F, using ice if necessary.
- I. The final application shall have a minimum of four (4) hours cure time before subjected to actual flow.

3.03 INTERCEPTOR REHABILITATION ACCEPTANCE

- A. After the interceptor rehabilitation work has been completed, the interceptor shall be visually inspected by the Subcontractor in the presence of the Purchaser’s Representative and the work shall be accepted if found satisfactory to the Purchaser’s Representative. The finished surface shall be free of blisters, “runs” or “sags” or other indications of uneven coating thickness. No evidence of visible leaks shall be allowed.
- B. After the protective coating has set hard to the touch, it shall be inspected with high-voltage holiday detection equipment. The surface shall first be dried, an induced holiday shall then be made onto the coated surface and shall serve to determine the minimum/maximum voltage to be used to test the coating for holidays at that particular area. The spark tester shall be initially set at 100 volts per 1 mil (25 microns) of film thickness applied but may be adjusted as necessary to detect the induced holiday. All detected holidays shall be marked and repaired by abrading the coating surface with grit disk paper or other hand tooling method. After abrading and cleaning, additional protective coating material can be hand applied to the repair area. All tough-up/repair procedures shall follow the protective coating manufacturer’s recommendations.

CITY OF MEMPHIS – STANDARD CONSTRUCTION SPECIFICATIONS
Modified By SARP10 Program
SECTION 09920 – INTERCEPTOR COATING

1. The Purchaser reserves the right to reject the interceptor coatings that do not pass holiday testing requirements, and replacement shall be at the Subcontractor's expense. A significant number of leaks on a single interceptor or significant number of interceptors leaking shall be considered as a basis for rejection and replacement of interceptors.

3.04 WARRANTY AND GUARANTEE FOR REHABILITATED INTERCEPTORS

- A. The warranty period shall be for a period of five (5) years from the installation date of the tube. Any defects, which in the opinion of the Purchaser, will affect the integrity or strength of the pipe shall be repaired at the Subcontractor's expense in a manner acceptable to the Purchaser. The material shall be unconditionally guaranteed to meet or exceed the design criteria detailed in this Specification.

3.05 SITE RESTORATION

- A. The Subcontractor shall restore or replace all removed or damaged paving, curbing, sidewalks, gutters, shrubbery, fences, sod or other disturbed surfaces or structures to a condition equal to that before the work began, to the satisfaction of the Program Manager, and shall furnish all labor and material incidental thereto.
- B. The restoration of existing property or structures shall be done as promptly as practicable and shall not be left until the end of the contract period. Compensation for this work will be included in the rehabilitation item to which it pertains.

PART 4 – DELIVERABLES

4.01 Provide post-rehabilitation PACP inspection for each interceptor.

4.02 FINAL VIDEO INSPECTION

- A. A PACP CCTV inspection in accordance with Section 00004 shall be submitted after liner installation. This inspection shall be performed, one section at a time, by a color video inspection system. The finished CIPP shall be continuous over the entire length of all inversion runs and be free of dry spots, wrinkles, pinholes, holidays, lifts, and delaminations. All service entrances shall be accounted for and shall be unobstructed including all rehabilitated service lateral connection repair(s). If, in the judgment of the Purchaser, any unsatisfactory conditions are present, the Subcontractor shall correct conditions in these areas at no additional cost to the Purchaser.

PART 5 – MEASUREMENTS

5.01 STANDARD INTERCEPTOR COATING

- A. A protective coating system consisting of a base coat and top coat with thicknesses in accordance with manufacturer's recommendations shall be measured per linear foot of

CITY OF MEMPHIS – STANDARD CONSTRUCTION SPECIFICATIONS
Modified By SARP10 Program
SECTION 09920 – INTERCEPTOR COATING

interceptor from the downstream manhole or to the upstream manhole where specified on the maps and plans.

5.02 BYPASS PUMPING

Bypass pumping shall be measured in a lump sum basis for the Interceptor Rehabilitation.

5.03 SITE PREPARATION AND RESTORATION

A. The area to be considered for measurement will be the limit of the construction area unless otherwise directed by the Purchaser.

B. When the Proposal sheet(s) do(es) not contain an item for Site Preparation and Restoration, this work will be required within the construction limits and will not be paid for directly but will be considered as a subsidiary obligation of the Subcontractor under other contract items.

5.04 ADDITIONAL LEAK-STOP GROUTING

A. Additional continuous leak-stop grouting beyond four hours per interceptor structure shall be measured per hour.

5.05 HEAVY CLEANING 96-INCH PIPE

Heavy Cleaning shall be measured by linear foot of heavy cleaning of 96-inch Pipe.

PART 6 – PAYMENT

6.01 INTERCEPTOR COATING

A. Interceptor coating shall be paid for per linear foot and shall include consist of surface preparation, up to four hours of continuous leak-stop grouting, sprayed on lining, and holiday testing.

6.02 BYPASS PUMPING

A. Bypass pumping will be paid on lump sum basis. This item includes all materials and labor necessary to properly comply with the bypass pumping requirements listed in the specification.

6.03 SITE PREPERATION AND RESTORATION

A. Payment will be made for Site Preparation and Restoration at the contract lump sum price, which will be full compensation for removal of trees, shrubs, plants, brush, rubbish, fences, manmade obstructions including but not limited to structures, abandoned cars and appliances, building foundations, and all other obstructions as may be directed by the Purchaser; the disposal of debris, removing of obstructions, and the restoration of fences, turfed areas, and all other items will be as specified in the Plans and Contract Documents or as directed by the Purchaser.

6.04 ADDITIONAL LEAK-STOP GROUTING

CITY OF MEMPHIS – STANDARD CONSTRUCTION SPECIFICATIONS
Modified By SARP10 Program
SECTION 09920 – INTERCEPTOR COATING

A. Additional continuous leak-stop grouting beyond four hours per interceptor shall be paid for per hour. This item includes all materials and labor necessary to complete the grouting.

6.05 HEAVY CLEANING 96-INCH

A. Heavy Cleaning shall be paid for at the unit price for each linear foot of each diameter of heavy cleaned sewers at the direction of the Program Manager and in accordance with the specification.

The unit price for Heavy Cleaning shall include the entire cost including but not limited to labor, mobilization and access, traffic control, appropriate disposal of sewer debris removed from sewer at permitted site and all other appurtenant work. Payment includes non-hydraulic jet efforts such as porcupines, cutters, power rodding, clam buckets, and other mechanical means, traffic control, and re-cleaning with hydraulic jet, labor, materials, and equipment necessary to clean mainline sufficiently to allow video reviewers a clear picture of pipe conditions.

No additional payment will be made for:

1. Additional passes of heavy cleaning if the inspection observation reveals roots, grease or other debris remaining in the sewer after the heavy cleaning passes.

6.06 PAYMENT WILL BE MADE UNDER:

<u>Item No.</u>	<u>Pay Item</u>	<u>Pay Unit</u>
09920-6.01.X	INTERCEPTOR COATING	LF
09920-6.02.X	BYPASS PUMPING	LS
09920-6.04	SITE PREP AND RESTORATION	LS
09920-6.06	ADDITIONAL LEAK STOP GROUTING	HR
09920.6.07	HEAVY CLEANING 96-INCH	LF

END OF SECTION 09920

MISCELLANEOUS CONTRUCTION REQUIREMENTS

I. SCOPE OF THE CONTRACT:

1. The Scope of work for this bid generally consist of installing cured in place pipe (CIPP) or coating system on approximately 1,350 feet of 96-inch diameter sewer main located near the intersection of I-40 and Hwy 51. Other related work will include bypass pumping, restoring the disturbed area, and installing special suction structure for bypass.
2. The Contract is for one of four total options to be bid. Bidder may choose to bid on any number of options at Bidder's discretion. If not bidding on an option shown, leave all unit prices blank.

2. ADDITIONS TO TECHNICAL SPECIFICATIONS:

- A. In the event of conflict between the technical specifications, Construction Drawings, the General Provisions, or Special Conditions contained herein, and/or product manufacturer's specifications, the more stringent specs shall apply. However, all conflicts shall be brought to the attention of the Purchaser for approval.
- B. The cost of all required material inspections and testing, including, but not limited to earthwork and concrete testing, shall by paid for by the subcontractor.
- C. Item No. 09930.01, Special Structure for Bypass
 1. This item is not specified in the technical specifications.
 2. This item includes all labor, materials and design cost to install Special Structure for Bypass.
 3. SARP10 will allow the installation of a permanent manhole structure to aid with the bypass and be left when the job is complete. The design of this structure shall be approved by SARP10 prior to installation.
 4. Payment will be at the contract unit price lump sum.

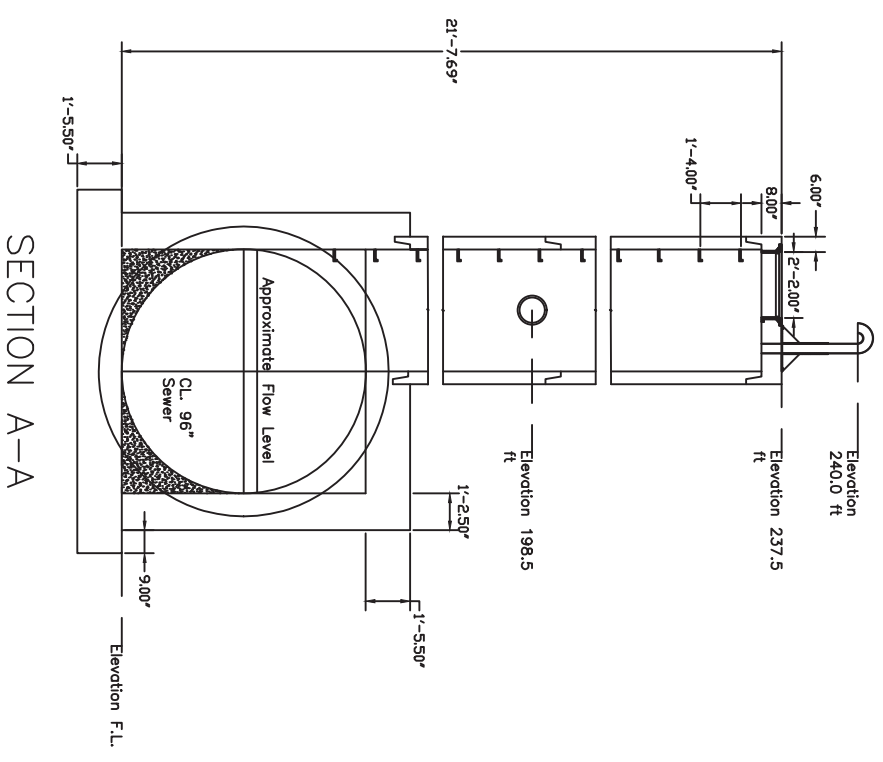
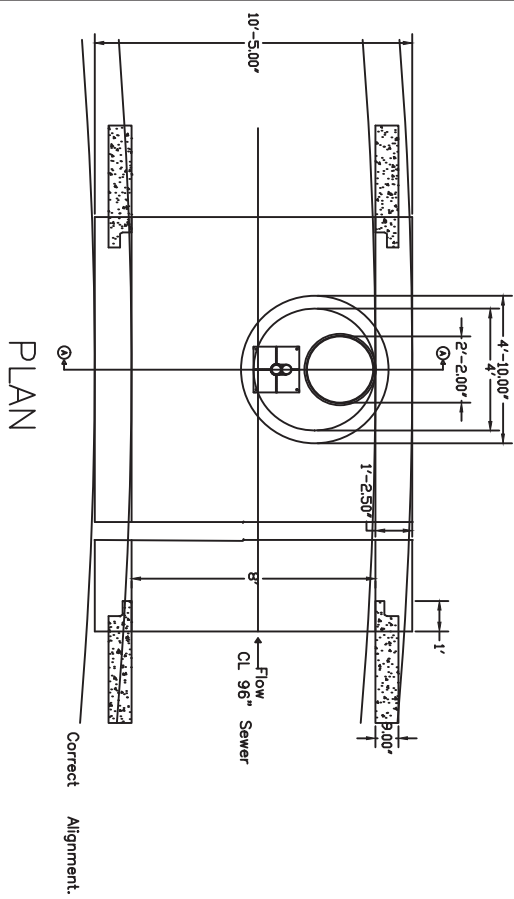

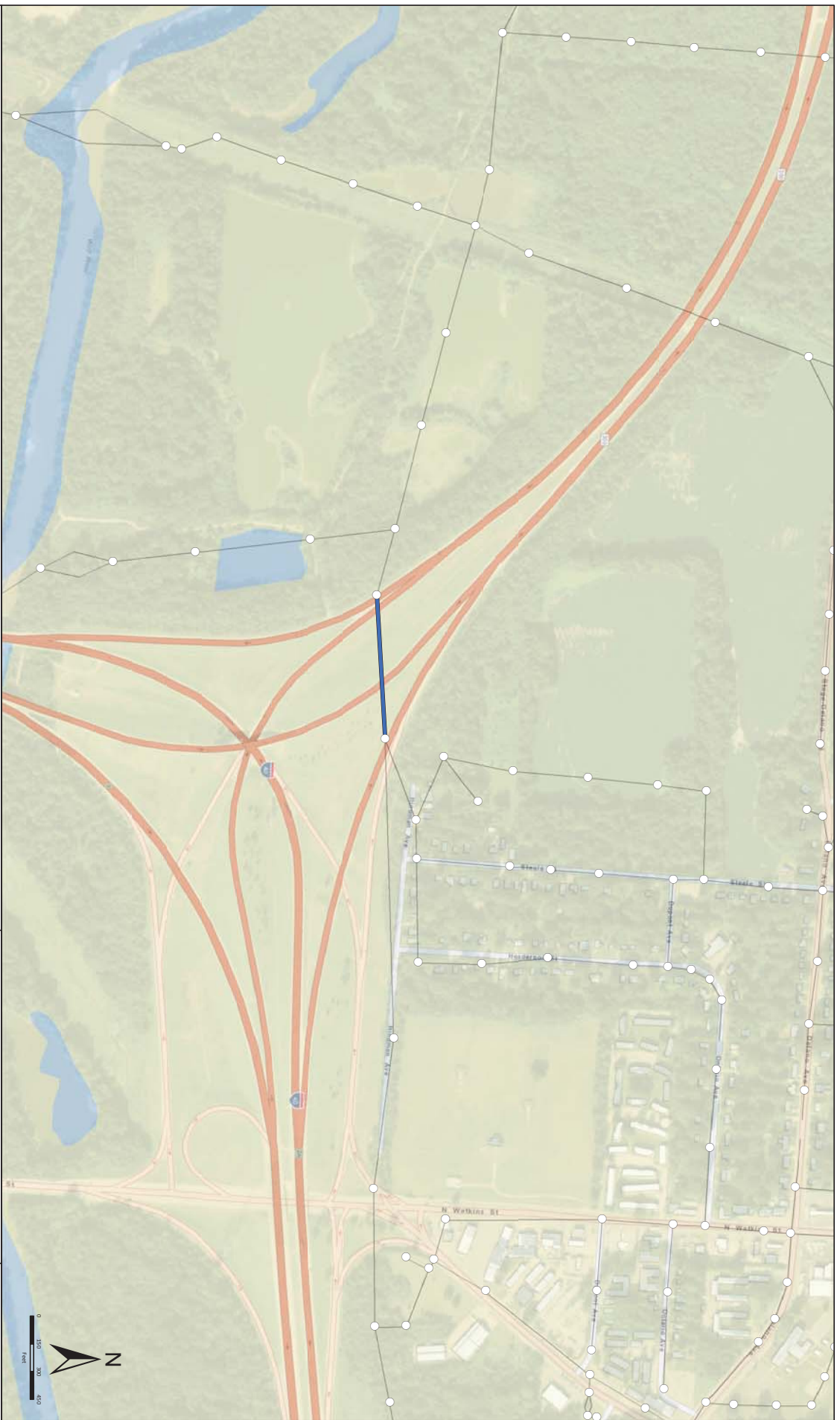

Legend

- █ Segment to be Rehabilitated
- Sanitary Manhole (No Rehab)
- Gravity Main (No Rehab)
- Pressurized Main (No Rehab)

WOLF RIVER 96" REHABILITATION

Date Generated: 1/22/2018

